

# INSTRUCTION MANUAL MS-SOUND DECODERS & MN – Non-Sound Decoder

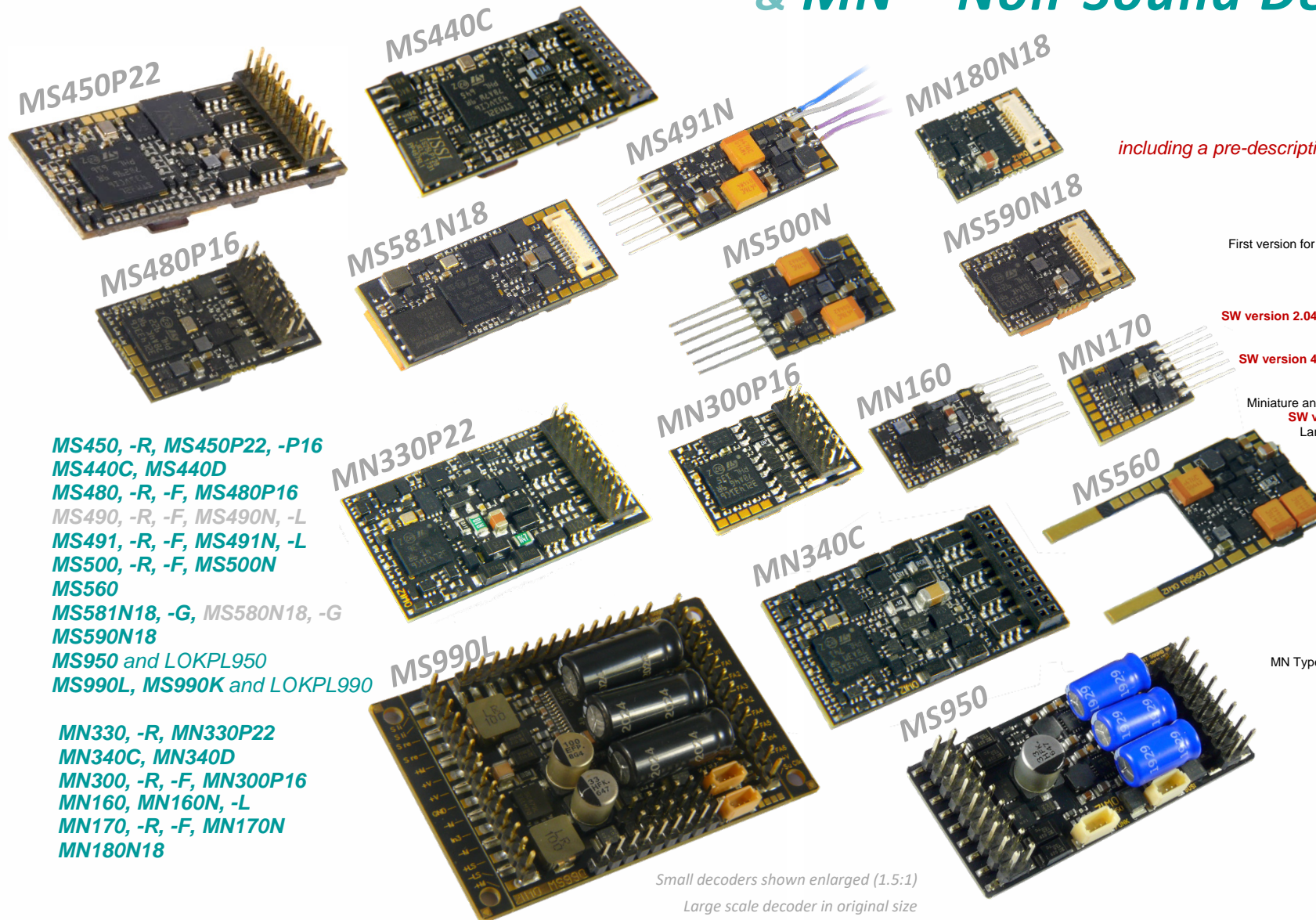

MS450, -R, MS450P22, -P16  
MS440C, MS440D  
MS480, -R, -F, MS480P16  
MS490, -R, -F, MS490N, -L  
MS491, -R, -F, MS491N, -L  
MS500, -R, -F, MS500N  
MS560  
MS581N18, -G, MS580N18, -G  
MS590N18  
MS950 and LOKPL950  
MS990L, MS990K and LOKPL990

MN330, -R, MN330P22  
MN340C, MN340D  
MN300, -R, -F, MN300P16  
MN160, MN160N, -L  
MN170, -R, -F, MN170N  
MN180N18

Small decoders shown enlarged (1.5:1)  
Large scale decoder in original size

for SW version 4.229  
including a pre-description of the features of version 5.00

| EDITIONS:  |  |
|--|--|
| First version for first delivery, <b>SW version 1.00</b> | --- 2018 04 17<br>2018 07 20<br>2018 08 23               |
| <b>SW version 2.00</b>                                   | --- 2019 01 08<br>2019 01 25<br>2019 02 20<br>2019 05 30 |
| <b>SW version 2.04 with lookout to later versions</b>    | --- 2019 08 08<br>2019 09 11<br>2019 11 22<br>2019 12 09 |
| <b>SW version 4 with lookout to later versions</b>       | --- 2020 03 05<br>2020 06 29                             |
| Miniature and NEXT types added, revisions                | ---  |
| <b>SW version 4.10 with lookout to 5</b>                 | --- german ed.   |
| Large scale types added, updates                         | ---  |
| <b>SW version 4.50</b>                                   | --- german ed.   |
| <b>SW version 4.75</b>                                   | --- german ed.<br>2021 05 12                             |
| <b>SW version 4.90</b>                                   | --- 2021 05 21   |
| <b>SW version 4.95</b>                                   | --- 2021 06 15<br>2021 06 29                             |
| <b>SW version 4.215</b>                                  | --- 2022 05 05<br>2022 05 27<br>2022 08 01<br>2022 11 10 |
| <b>SW version 4.225</b>                                  | --- 2022 12 05<br>2022 12 15<br>2023 02 01<br>2023 05 02 |
| MN Types and Sound Equalizing added                      | --- 2023 07 11<br>2023 10 31                             |



## Contents

|      |   |    |
|------|---|----|
| 1    | Overview of the types and type-dependent data.....  | 4  |
| 1.1  | MS sound decoders for "small" scales (N to 0) .....   | 4  |
| 1.2  | MS sound decoders for „big“ scales (0, 1, G, 2,...).....  | 5  |
| 1.3  | MN Non Sound Decoders for „small“ Scales (N to 0).....  | 6  |
| 2    | Technical Data, schematics, operation with mfx.....   | 7  |
| 3    | CVs in DCC operation.....   | 22 |
| 3.1  | Basic Configuration .....   | 22 |
| 3.2  | Decoder-ID, Load-Code .....   | 22 |
| 3.3  | Manufacturer ID, SW version.....  | 23 |
| 3.4  | Vehicle address(es) in DCC mode .....   | 24 |
| 3.5  | Analog operation .....  | 25 |
| 3.6  | Motor regulation and control .....  | 26 |
| 3.7  | Acceleration and deceleration momentum: .....   | 28 |
| 3.8  | Special Operating Mode "km/h speed regulation" .....  | 29 |
| 3.9  | ZIMO "signal-controlled speed influence" (HLU).....   | 30 |
| 3.10 | Stop in front of a red signal and driving slowly by "asymmetrical DCC-Signal" (Lenz ABC).....             | 30 |
| 3.11 | DC Brake Sections, "Märklin brake mode" .....   | 31 |
| 3.12 | Distance controlled stopping - Constant Braking Distance .....  | 32 |
| 3.13 | Shunting-, Half speed-, MAN-functions .....   | 33 |
| 3.14 | The NMRA-DCC function mapping.....  | 34 |
| 3.15 | Function mapping "without left shift" .....   | 34 |
| 3.16 | "Unilateral light suppression" .....  | 35 |
| 3.17 | The "Swiss Mapping" .....   | 35 |
| 3.18 | ZIMO "Input Mapping" SW version 3.00 and higher.....  | 38 |
| 3.19 | Dimming, High/Low beam and Direction Bits .....   | 38 |
| 3.20 | Flasher Effect.....   | 39 |
| 3.21 | Effects for function outputs (US and other lighting effects, smoke generators, uncouplers, .....          | 40 |
| 3.22 | Configuration of Smoke Generators .....   | 41 |
| 3.23 | Configuration of Electric Uncouplers .....  | 42 |
| 3.24 | SUSI pins: switchable to SUSI or I <sup>2</sup> C interface, logic level inputs and outputs or servo..... | 42 |
| 3.25 | Servo Configuration .....   | 43 |
| 3.26 | Additional CVs for large scale and special decoders .....   | 44 |
| 4    | RailCom - "Bidirectional communication" for DCC .....   | 44 |
| 5    | ZIMO SOUND – Selection and Programming.....   | 46 |
| 5.1  | CV #300 - procedures" SW version 5.00 or higher.....  | 47 |
| 5.2  | The test run for determining the motor's basic load SW version 5.00 and higher .....                      | 50 |
| 5.3  | SOUND: Basic settings independent of powertrain .....   | 50 |
| 5.4  | SOUND: Steam engine → sound basic configuration .....   | 52 |
| 5.5  | SOUND: Steam locomotive → Load and acceleration dependency .....  | 54 |
| 5.6  | Diesel and Electric engines → Diesel motor, Turbocharger Thyristor, Electric motor, .....                 | 55 |
| 5.7  | Coasting and Notching .....   | 57 |
| 5.8  | Random and Switch input sounds .....  | 58 |
| 6    | Sound equalizing (filter) of the MS sound decoders.....   | 59 |
| 7    | Installation and connection of the ZIMO decoder.....  | 61 |
| 8    | CV - Overview; CVs in numerical order .....   | 63 |
| 9    | Scripts for decoders, short description.....  | 81 |
| 10   | Software update and sound loading with MXULFA.....  | 82 |
| 11   | Service Notes.....  | 84 |

## CHANGE PROTOCOL of this instruction manual

|             |  |
|-------------|--|
| 2019 09 11: | Cover: MS440C<br>Page 3 - various changes<br>Page 34 - additional sound classes<br>Page 37 and following - added Diesel, Electro, random, ...<br>Page 34 and following - various changes and additional entries to the CV tables   |
| 2019 12 09: | Page 5 – MS950 added in decoder table; corrections (dimensions MS480, MS490, MS580, stay-alive capacitor circuitry), naming of MS580<br>Page 7 - Connection schematics for MS440C/D<br>Page 25 - Changes to CV #190/191  |
| 2020 01 23: | MS480, MS490, MS580 schematics added, MS450, MX450 schematics modified   |
| 2020 02 07  | Page 35: Correction driving sound, table of volume settings  |
| 2020 03 25  | Drawings and text stay-alive capacitor of MS580  |
| 2020 06 29  | Corrections accordingly and summarising the German-language editions<br>Connection diagrams and types overview updated   |
| 2021 02 03  | Corrections accordingly and summarising the German-language editions   |
| 2021 04 23  | Addition of "StayAlive" to connection diagrams, various CV #153,...  |
| 2021 04 29  | Additions to the type table, separation into "small" types and large scale decoders  |
| 2021 05 12  | Addition of cover images   |
| 2021 05 21  | Improvements of the schematics, new pages for MS990L, -K<br>Chapter 7: Software Update and Sound Load with MXULFA<br>Chapter 3.26: New CV #264 low voltage for large scale and special decoders<br>Chapter 3.25: Addition for servo control lines 5-8<br>Chapter 5: CV additions according to the above points |
| 2021 06 14  | NEW: Chapter 3.12 "Distance-controlled stopping - constant braking distance".<br>Chapter 3.11: New, reference to CV #29, Chapter 3.1: Description for CV #27 new   |
| 2021 06 29  | Chapter 3.24 modified, Alternative application of SUSI pins; Various corrections   |
| 2022 05 05  | Cover: MS560   |
| 2022 08 01  | MS480, MS490, MS500, MS590: Rev. B. Details of stabilised low-voltage sources added to diagrams and tables. Chapter 2: Warning for PIKO boards   |
| 2022 11 10  | Chapter 6: Installation notes for older locomotives<br>several CVs changed or added (CV #10, #195-#199, #134, ...),<br>Chapter numbers in CV list (chapter 8) are now clickable  |
| 2022 12 05  | Correction of the connection diagrams of MS950 and MX605FL (see MS560)   |
| 2022 12 15  | various corrections and additions (CV #203 / #204, missing links,...)  |
| 2023 02 01  | added CV #250 for MN decoders, CV #27 – Bit 2 removed, Added Information for CV #49, #50, #56  |
| 2023 04 27  | several small corrections  |
| 2023 07 11  | Addition of MN Decoders, new Chapter Sound equalising, several small changes and updates   |
| 2023 10 31  | various corrections and additions in regards to the german version   |
| 2023 12 18  |  |

## SUMMARY of features not yet implemented in SW version 4.229 (preview to 5.00)

- ⊖ Motor brake (for non-worm gear): CV #151 (only if not in consist, otherwise it is used differently)
- ⊖ Adaptive acceleration and special possibilities for acceleration: CVs #123, #394, #246, #348 \*
- ⊖ Change between individual and consist address via key, CV #197; reduction control, CV #151
- ⊖ Special operating state "km/h regulation": CVs #135, #136 \*)
- ⊖ The "CV #300 procedure" and test drive for basic load: CVs #300 - #302
- ⊖ Sound classes rolling sounds, second thyristor, panto sounds: CVs #588, #593, #594, #596, #598
- ⊖ Special measures (interruption Acceleration) for diesel-mechanical locomotives: #364, #365
- ⊖ Large scale decoder: 2nd smoke generator; with 4.205 already cylinder drainage and start 2nd diesel engine
- ⊖ "Stereo" (large scale decoder, 2 sound output channels, settings in CV page 31/32 = 145/0);
- ⊖ Tilt and curvature sensor launch for display on controller and sound influence.
- ⊖ Control influence CV #58, load dependence steam/diesel: CVs #277-#279, #280, #154, #158, #378-#379
- ⊖ Speed dependent high beam (Rule 17): CV #399

"mfx" is a registered trademark of Fa. Gebr. Märklin & Cie GmbH.  
"RailCom" is a registered trademark of Lenz GmbH.

\*) the marked block of features will be updated in regards to the MX generation, because, on the one hand the performance will be enhanced, and on the other hand, it will present advances for future operation types (first planned new feature in this regard: display of target distance on the controller).

Notes for users switching from MX to MS & MN:

### The relationship between MS - Sound Decoders & MN - non-sound decoders

In contrast to earlier decoder generations (at ZIMO and other manufacturers), the sound decoders - i.e. the more elaborate types - were the first on the market at MS & MN. The types without sound are largely derived from this: so they are NOT trimmed for low cost, but for optimal functionality as it results from the match:

**MS sound decoders and MN non-sound decoders are of one mold.**

Identical hardware, apart from the special components for sound generation, of course, and jointly developed software mean

- same driving behavior (important for locomotive networks, etc.),
- same (very similar) configuration, including ZIMO specials like "Swiss Mapping", scripts, registration under DCC and mfx, etc.
- same project organization (sound projects or decoder projects)

Therefore, there is this **one shared operating manual** for sound and non-sound decoders. Sections that refer only to sound can of course be ignored for non-sound.

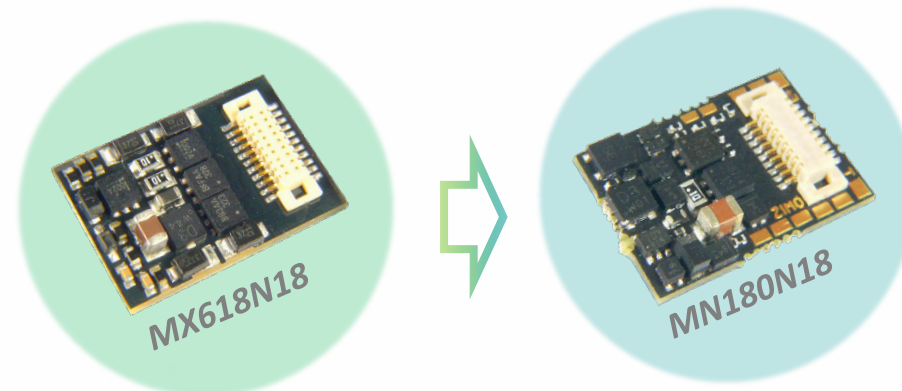
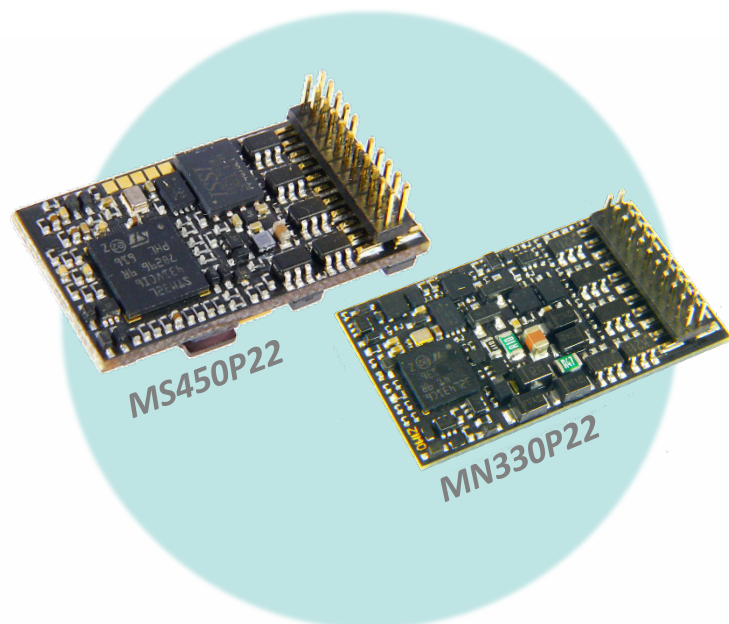

### Differences concerning operation and config. (MX → MS & MN):

Apart from the new sound quality (see below) and other improvements, the MS and MN decoders are very similar to the MX decoders. In some cases, though, **specific settings (CVs)** behave differently or have additional functions for better operation:

**CV #12** (Operation types): according to VHDM-standard, individual operating states can be locked (DCC, mfx, MM, analog), by default all unlocked. **Chap. 3.1**

**CVs #5, #57** (top speed, Reg.ref.): CV #5 gets the original configuration to reduce the top speed back, which was in CV #57 in MX decoders. CV #57, therefore, is used to select, whether the speed depends on running voltage or if voltage variations can be eliminated by references to a lower value (e.g. 14 V). NOT in SW. 4.50! **Chapter 3.6**

**CV #56** (P- and I-value): only effective, if CVs #147, #148, #149 = 0 **Chapter 3.6**

**CV #144** (Programm./Update lock): dropped, no longer necessary in new decoders.

**CV #147, #148, #149** (PID settings): new CVs, enable separated, high-resolution adjustment of integral, differential, and proportional values for EMF-load balance control, replace CV #56 if <> 0. **Chapter 3.6**

**CVs #190, #191** (Brightening up and dimming times for effects 88, 89, 90): New definition due to broader range of timeset (now 0-320s). **Chapter 3.21**

**CVs #49, #50** In contrast to MX decoders the values of CV #3/#49 or #4/#50 are not added together, but the higher value is used. **Chapter 3.7**



# 1 Overview of the types and type-dependent data

Technical data for all MS sound decoders in the next chapter!

## 1.1 MS sound decoders for “small” scales (N to 0)

|   | Standard HO   |   |  | Miniature   |   |   |   | KATO-Interface  |   |   |
|---|---|---|--|---|---|---|---|---|---|---|
|   | MS450,<br>MS450R  | MS450P22,<br>MS450P16   | MS440C/D<br><small>MTC acc. VHDM Std.<br/>MTC ZIMO Variant</small>     | MS480,<br>MS480R, MS480F  | MS480P16  | MS490,<br>MS490R, MS490F  | MS490N, L   | MS500,<br>MS500R, MS500F  | MS500N  | MS560   |
| Dimensions(mm)  | 30 x 15 x 4   | 30 x 15 x 4   | 30 x 15 x 4  | 19 x 11 x 3.1   | 19 x 11 x 3.1   | 19 x 8.6 x 2.9*   | 19 x 8.6 x 2.9*   | 14 x 10 x 2.6*  | 14 x 10 x 2.6*  | 27 x 14 x 2.6*  |
| <b>Connections</b><br><small>Wires and/or standardized interfaces</small>             | <b>13 wires</b><br>NEM-652  | <b>PluX22</b><br>PluX16   | <b>21 MTC</b> , FO3-FO6:<br>Logic-level (std.)/<br>„amplified“ outputs | <b>13 wires</b><br>NEM-652, NEM-651                                 | <b>PluX-16</b>  | <b>12 wires</b><br>NEM-652, NEM-651                                 | <b>NEM-651</b><br>directly  | <b>12 wires</b><br>NEM-652, NEM-651                                 | <b>NEM-651</b><br>directly  | <b>KATO</b><br>(like EM13)  |
| Continuous Current<br><small>motor+sound+FOs<br/>(peak)</small>                       | <b>1.2 A</b><br>(2.5 A)   | <b>1.2 A</b><br>(2.5 A)   | <b>1.2 A</b><br>(2.5 A)  | <b>0.8 A</b><br>(1.5 A)   | <b>0.8 A</b><br>(1.5 A)   | <b>0.7 A</b><br>(1.5 A)   | <b>0.7 A</b><br>(1.5 A)   | <b>0.7 A</b><br>(1.5 A)   | <b>0.7 A</b><br>(1.5 A)   | <b>0.7 A</b><br>(1.5 A)   |
| of which: cont. motor output<br><small>(peak)</small>                                 | <b>1.2 A</b><br>(2.5 A)   | <b>1.2 A</b><br>(2.5 A)   | <b>1.2 A</b><br>(2.5 A)  | <b>0.8 A</b><br>(1.5 A)   | <b>0.8 A</b><br>(1.5 A)   | <b>0.7 A</b><br>(1.5 A)   | <b>0.7 A</b><br>(1.5 A)   | <b>0.7 A</b><br>(1.5 A)   | <b>0.7 A</b><br>(1.5 A)   | <b>0.7 A</b><br>(1.5 A)   |
| of which: Function Output<br><small>ONLY function outputs combined</small>            | <b>0.8 A</b>  | <b>0.8 A</b>  | <b>0.8 A</b>   | <b>0.6 A</b>  | <b>0.6 A</b>  | <b>0.5 A</b>  | <b>0.5 A</b>  | <b>0.5 A</b>  | <b>0.5 A</b>  | <b>0.5 A</b>  |
| Function Outputs<br><small>incl. 2 x headlights (+ logic level outputs)</small>       | <b>10</b> 4 with wires,<br>6 on s. pads<br>(+ 2 logic level<br>+ 1 alt. use of IN1) | <b>10</b> 9/4 on plug,<br>1/6 on s. pad<br>(+ 2 logic level<br>+ 1 alt. use of IN1) | <b>4/8</b> all 4/8<br>on plug,<br>(+ 6/2 logic level)                  | <b>6</b> 4 with wires,<br>2 on s. pads<br>(+ 2 logic level)         | <b>6</b> 4 on plug,<br>2 on s. pad<br>(+ 2 logic level)             | <b>4</b> all 4 with wires<br>(+ 2 logic level)                      | <b>4</b> 2 on plug,<br>2 on s. pads<br>(+ 2 logic level)            | <b>4</b> all 4 with wires<br>(+ 2 logic level)                      | <b>4</b> 2 on plug,<br>2 on s. pads<br>(+ 2 logic level)            | <b>2</b> all 2 on<br>s. pads<br>(+ 2 logic level)                   |
| Servo - control lines<br><small>(complete with 5 V supply)</small>                    | <b>2</b> alternative use<br>of logic-level<br>(NO, ext. 5 V needed)                 | <b>2</b> alternative use<br>of logic-level<br>(NO, ext. 5 V needed)                 | <b>2</b> alternative use<br>of logic-level<br>(NO, ext. 5 V needed)    | <b>2</b> alternative use<br>of logic-level<br>(NO, ext. 5 V needed) | <b>2</b> alternative use<br>of logic-level<br>(NO, ext. 5 V needed) | <b>2</b> alternative use<br>of logic-level<br>(NO, ext. 5 V needed) | <b>2</b> alternative use<br>of logic-level<br>(NO, ext. 5 V needed) | <b>2</b> alternative use<br>of logic-level<br>(NO, ext. 5 V needed) | <b>2</b> alternative use<br>of logic-level<br>(NO, ext. 5 V needed) | <b>2</b> alternative use<br>of logic-level<br>(NO, ext. 5 V needed) |
| SUSI - connection<br><small>alternatively SUSI, I2C, Sound loading</small>            | <b>yes</b> alternative use<br>of logic-level<br>on solder pads                      | <b>yes</b> alternative use<br>of logic-level<br>on PluX                             | <b>yes</b> alternative use<br>of logic-level<br>on MTC                 | <b>yes</b> alternative use<br>of logic-level<br>on solder pads      | <b>yes</b> alternative use<br>of logic-level<br>on PluX             | <b>yes</b> alternative use<br>of logic-level<br>on solder pads      | <b>yes</b> alternative use<br>of logic-level<br>on solder pads      | <b>yes</b> alternative use<br>of logic-level<br>on solder pads      | <b>yes</b> alternative use<br>of logic-level<br>on solder pads      | <b>yes</b> alternative use<br>of logic-level<br>on solder pads      |
| Switching Inputs<br><small>für cam sensors, Reed switches, a.o.</small>               | <b>1</b> on s. pad<br><b>+ 2</b> alternative use<br>of logic-level                  | <b>1</b> on PluX<br><b>+ 2</b> alternative use<br>of logic-level                    | <b>2</b> on MTC<br><b>+ 2</b> alternative use<br>of logic-level        | <b>2</b> alternative use<br>of logic-level                          | <b>2</b> alternative use<br>of logic-level                          | <b>2</b> alternative use<br>of logic-level                          | <b>2</b> alternative use<br>of logic-level                          | <b>2</b> alternative use<br>of logic-level                          | <b>2</b> alternative use<br>of logic-level                          | <b>2</b> alternative use<br>of logic-level                          |
| stabilised Low Voltage<br><small>to be taken from</small>                             | <b>5 V possible</b><br>(see connection plan)  | <b>5 V possible</b><br>(see connection plan)  | <b>5 V</b> max 50 mA<br>on MTC   | <b>5 V**</b> max 50 mA<br>on solder pad                             | <b>5 V**</b> max 50 mA<br>on solder pad                             | <b>5 V**</b> max 50 mA<br>on solder pad                             | <b>5 V**</b> max 50 mA<br>on solder pad                             | <b>5 V</b> max 50 mA<br>on solder pad                               | <b>5 V</b> max 50 mA<br>on solder pad                               | <b>5 V</b> max 50 mA<br>on solder pad                               |
| Energy Storage - connect.<br><small>15 V - capacitors DIRECTLY on the decoder</small> | <b>yes</b><br>with wires  | <b>yes</b><br>on PluX   | <b>yes</b><br>on s. pads   | <b>yes</b><br>on s. pad<br>max 1000µF                               | <b>yes</b><br>on PluX<br>max 1000µF                                 | <b>yes</b><br>on s. pads<br>max 1000µF                              | <b>yes</b><br>on s. pads<br>max 1000µF                              | <b>yes</b><br>on s. pads<br>max 1000µF                              | <b>yes</b><br>on s. pads<br>max 1000µF                              | <b>no</b>   |
| Speaker Output<br><small>dep. on Decoder 8Ω or 4Ω (2 x 8Ω parallel)</small>           | <b>1</b> 3 Watt / 4Ω<br>with wires  | <b>1</b> 3 Watt / 4Ω<br>on PluX   | <b>1</b> 3 Watt / 4Ω<br>on MTC   | <b>1</b> 1 Watt / 8Ω<br>with wires                                  | <b>1</b> 1 Watt / 8Ω<br>on PluX                                     | <b>1</b> 1 Watt / 8Ω<br>on wires                                    | <b>1</b> 1 Watt / 8Ω<br>on wires                                    | <b>1</b> 1 Watt / 8Ω<br>on wires                                    | <b>1</b> 1 Watt / 8Ω<br>on wires                                    | <b>1</b> 1 Watt / 8Ω<br>on wires                                    |

\*) To make the small dimensions possible, the decoder families MS491, MS500, MS560 and MS590N18 are NOT mfx-able!

\*\*) Valid for MS480 and MS490 decoders (all types in each case) from revision B (produced from approx. August 2022 onwards).



## 1.2 MS sound decoders for “big” scales (0, 1, G, 2,...)

| <i>Next</i>  |   |
|--|---|
| <i>MS580N18, MS590N18</i><br><small>MS580N18G with external mini Goldcaps</small>  | <i>MS590N18</i>   |
| 25 x 10.5 x 4  | 15 x 9.5 x 3.3 *  |
| <i>Next18</i>  | <i>Next18</i>   |
| <b>0.8 A</b><br><small>(1.5 A)</small>   | <b>0.7 A</b><br><small>(1.5 A)</small>  |
| <b>0.8 A</b><br><small>(1.5 A)</small>   | <b>0.7 A</b><br><small>(1.5 A)</small>  |
| <b>0.6 A</b>   | <b>0.5 A</b>  |
| <b>4</b> all on plug<br>(+ 2 logic level)<br>(+ 2 LED (6 mA))  | <b>4</b> all 4 on plug,<br>(+ 3 logic level)                                    |
| <b>2</b> alternative use of logic-level<br><small>(NO, ext. 5 V needed)</small>  | <b>2</b> alternative use of logic-level<br><small>(NO, ext. 5 V needed)</small> |
| <b>yes</b> alternative use of logic-level on Next18-plug   | <b>yes</b> alternative use of logic-level on Next18-plug                        |
| 2 alternative use of logic-level   | 2 alternative use of logic-level  |
| 5 V <u>possible</u><br><small>(see connection plan)</small>  | no  |
| <b>internal buffer</b><br><small>(in MS580N18)</small><br><b>yes</b> <small>(in addition to internal external 5V-Tantals on solder pads)</small> | no  |
| <b>1</b> 1 Watt / 8 Ω on Next18  | <b>1</b> 1 Watt / 8 Ω on Next18   |

|  | <i>Large Scale</i>   |  |   |
|--|--|--|---|
|  | <i>MS950</i>   | <i>MS990L</i>  | <i>MS990K</i>   |
| Dimensions (mm)  | 50 x 23 x 13   | 50 x 40 x 13<br><small>(without breakaway tabs)</small>  | 50 x 40 x 13<br><small>(without breakaway tabs)</small>   |
| <i>Connections</i><br><small>Wires and/or standardized interfaces</small>  | <i>Pin headers</i>   | <i>Pin headers</i>   | <i>Screw terminals</i>  |
| Continuous Current<br><small>Motor+Sound+FOs (peak)</small>  | <b>4 A</b><br><small>(10 A)</small>  | <b>6 A</b><br><small>(10 A)</small>  | <b>6 A</b><br><small>(10 A)</small>   |
| of which: cont. motor output<br><small>(peak)</small>  | <b>4 A</b><br><small>(10 A)</small>  | <b>6 A</b><br><small>(10 A)</small>  | <b>6 A</b><br><small>(10 A)</small>   |
| of which: Function Outputs<br><small>ONLY Function Outputs combined</small>  | <b>2 A</b>   | <b>2 A</b>   | <b>2 A</b>  |
| Function Outputs<br><small>incl. 2 x Headlights (+ logic level outputs)</small>  | <b>11</b> all 11 on plug<br>(+ 3 logic level)  | <b>15</b> all 15 on plug   | <b>15</b> all 15 on plug  |
| Low Voltage<br><small>5 V for Servos a.o. Consumers<br/>5 V resp. 10 V Audio voltage<br/>variable low voltage from 1.5 V</small> | <b>1.5 A</b><br><b>0.5 A</b> (5 V <small>do not overload!</small> )<br>not available   | <b>1.5 A</b><br><b>0.5 A</b> (10 V <small>do not overload!</small> )<br><b>2 A</b>   | <b>1.5 A</b><br><b>0.5 A</b> (10 V <small>do not overload!</small> )<br><b>2 A</b>  |
| Servo - Control Lines<br><small>(complete connection with 5V supply)</small>   | <b>2</b> Servo control line<br>+ 2 alternative use of logic level  | <b>6</b> complete 3-pole Servo connections<br>+ 2 alternative use of logic level   | <b>6</b> complete 3-pole Servo connections<br>+ 2 alternative use of logic level  |
| SUSI - Connection<br><small>optional SUSI, I2C, Sound loading protocol</small>   | <b>yes</b> own 4-pin SUSI plug   | <b>yes</b> own 4-pin SUSI plug and <b>second</b> SUSI-interface pin headers  | <b>yes</b> own 4-pin SUSI plug and <b>second</b> SUSI-interface clamps  |
| Switching inputs<br><small>for axis sensors, reed contacts, etc.</small>   | <b>4</b> on plug<br>+ 2 alternative use of logic level   | <b>4</b> on plug<br>+ 2 alternative use of logic level   | <b>4</b> on plug<br>+ 2 alternative use of logic level  |
| Energy Storage- Connection<br><small>15V - Elkos/Supercaps DIRECTLY on Decoder</small>   | <b>internal energy stor.</b> from 3 Supercaps<br><b>yes</b> <small>(add. to internal storage)</small><br><b>external</b> Elkos/Supercap-Block (15 V) on s.pads | <b>internal energy stor.</b> from 3 Supercaps<br><b>yes</b> <small>(add. to internal storage)</small><br><b>external</b> Elkos/Supercap-Block (15 V) on pins | <b>internal energy storage</b> from 3 Supercaps<br><b>yes</b> <small>(add. to internal)</small><br><b>external</b> Elkos/Supercap-Block (15V) on pins |
| Loudspeaker - Outputs<br><small>dep. on Decoder 8Ω or 4Ω (2 x 8Ω parallel)</small>   | <b>2</b> <b>3 Watt / 4 Ω</b> on pins   | <b>2</b> <b>10 Watt / 4 Ω</b> on pins  | <b>2</b> <b>10 Watt / 4 Ω</b> on clamps   |



### 1.3 MN Non Sound Decoders for „small” Scales (N to 0)

**NOTE:** There are NO MN Non-Sound Decoders for large scale!

|   | Standard HO   |   |  | Miniature  |  |  |  | Next   |   |  |
|---|---|---|--|--|--|--|--|--|---|--|
|   | MN330,<br>MN330R  | MN330P22  | MN340C/D<br><small>MTC acc. VHDM std.<br/>MTC ZIMO variant</small>                         | MN300,<br>MN300R, MN300F   | MN300P16   | MN170,<br>MN170R, MN170F   | MN170N   | MN160  | MN160N,<br>MN160L   | MN180N18   |
| Dimensions (mm)   | 30 x 15.3 x 2.2<br>single-sided assemb.   | 30 x 15.3 x 2.2<br>single-sided assemb.   | 28.6 x 15.3 x 2.5<br>single-sided assemb.  | 17.6 x 10.5 x 3.2 *  | 17.6 x 10.5 x 3.2 *  | 12 x 8.6 x 2.3 *   | 12 x 8.6 x 2.3 *   | 13 x 7.5 x 1.6<br>single-sided assemb. *                                 | 13 x 7.5 x 1.6<br>single-sided assemb. *                              | 13.3 x 9.5 x 2.6 *   |
| Connections<br><small>Wires and/or standardized interfaces</small>                    | 11 wires<br>NEM-652   | PluX22  | 21 MTC, FO3-FO6:<br>Logic-level (std.)/<br>„amplified” outputs                             | 11 wires<br>NEM-652, NEM-651   | PluX-16  | 9 wires<br>NEM-652, NEM-651  | NEM-651<br>directly  | 7 wires  | NEM-651<br>directly   | Next18   |
| Continuous Current<br><small>motor+sound+FOs (peak)</small>                           | 1.2 A<br>(2.5 A)  | 1.2 A<br>(2.5 A)  | 1.2 A<br>(2.5 A)   | 1.0 A<br>(1.5 A)   | 1.0 A<br>(1.5 A)   | 0.7 A<br>(1.5 A)   | 0.7 A<br>(1.5 A)   | 0.5 A<br>(1 A)   | 0.5 A<br>(1 A)  | 0.7 A<br>(1.5 A)   |
| of which: cont. motor output<br><small>(peak)</small>                                 | 1.2 A<br>(2.5 A)  | 1.2 A<br>(2.5 A)  | 1.2 A<br>(2.5 A)   | 1.0 A<br>(1.5 A)   | 1.0 A<br>(1.5 A)   | 0.7 A<br>(1.5 A)   | 0.7 A<br>(1.5 A)   | 0.5 A<br>(1 A)   | 0.5 A<br>(1 A)  | 0.7 A<br>(1.5 A)   |
| of which: Function Output<br><small>ONLY function outputs combined</small>            | 0.8 A   | 0.8 A   | 0.8 A  | 0.8 A  | 0.8 A  | 0.6 A  | 0.6 A  | 0.5 A  | 0.5 A   | 0.6 A  |
| Function Outputs<br><small>incl. 2 x headlights (+ logic level outputs)</small>       | 10<br><small>4 with wires,<br/>6 on s. pads<br/>(+ 2 logic level<br/>+ 1 alt. use of IN1)</small> | 10<br><small>9 on plug,<br/>1 on s. pad<br/>(+ 2 logic level<br/>+ 1 alt. use of IN1)</small> | 4/8<br><small>all 4/8<br/>on plug,<br/>(+ 6/2 logic level<br/>+ 2 alt. use of INs)</small> | 6<br><small>4 with wires,<br/>2 on s. pads<br/>(+ 2 logic level)</small>         | 6<br><small>4 on plug,<br/>2 on s. pad<br/>(+ 2 logic level)</small>             | 6<br><small>4 with wires resp.<br/>2 on plug,<br/>2 resp. 4 on s.pads<br/>(+ 2 Logikpegel)</small> | 6<br><small>2 on pins,<br/>4 on s. pads<br/>(+ 2 logic level)</small>            | 4<br><small>2 with wires,<br/>2 on s. pads<br/>(+ 2 logic level)</small> | 4<br><small>2 on pins,<br/>2 on s. pads<br/>(+ 2 logic level)</small> | 4<br><small>all 4<br/>on plug<br/>(+ 4 logic level)</small>                      |
| Servo - control lines<br><small>(complete with 5 V supply)</small>                    | 2<br><small>alternative use<br/>of logic-level<br/>(NO, ext. 5 V needed)</small>                  | 2<br><small>alternative use<br/>of logic-level<br/>(NO, ext. 5 V needed)</small>              | 2<br><small>alternative use<br/>of logic-level<br/>(NO, ext. 5 V needed)</small>           | 2<br><small>alternative use<br/>of logic-level<br/>(NO, ext. 5 V needed)</small> | 2<br><small>alternative use<br/>of logic-level<br/>(NO, ext. 5 V needed)</small> | 2<br><small>alternative use<br/>of logic-level<br/>(NO, ext. 5 V needed)</small>                   | 2<br><small>alternative use<br/>of logic-level<br/>(NO, ext. 5 V needed)</small> | -  | -   | 2<br><small>alternative use<br/>of logic-level<br/>(NO, ext. 5 V needed)</small> |
| SUSI - connection<br><small>alternatively SUSI, I2C, Sound loading</small>            | yes<br><small>alternative use<br/>of logic-level<br/>on solder pads</small>                       | yes<br><small>alternative use<br/>of logic-level<br/>on PluX</small>                          | yes<br><small>alternative use<br/>of logic-level<br/>on MTC</small>                        | yes<br><small>alternative use<br/>of logic-level<br/>on solder pads</small>      | yes<br><small>alternative use<br/>of logic-level<br/>on PluX</small>             | yes<br><small>alternative use<br/>of logic-level<br/>on solder pads</small>                        | yes<br><small>alternative use<br/>of logic-level<br/>on solder pads</small>      | -  | -   | yes<br><small>alternative use<br/>of logic-level<br/>on Next18</small>           |
| Switching Inputs<br><small>für cam sensors, Reed switches, a.o.</small>               | 1<br><small>on s. pad<br/>+ 2 alternative use<br/>of logic-level</small>                          | 1<br><small>on PluX<br/>+ 2 alternative use<br/>of logic-level</small>                        | 2<br><small>on MTC<br/>+ 2 alternative use<br/>of logic-level</small>                      | 2<br><small>alternative use<br/>of logic-level</small>                           | 2<br><small>alternative use<br/>of logic-level</small>                           | 2<br><small>alternative use<br/>of logic-level</small>   | 2<br><small>alternative use<br/>of logic-level</small>                           | -  | -   | 2<br><small>alternative use<br/>of logic-level</small>                           |
| Energy Storage - connect.<br><small>15 V - capacitors DIRECTLY on the decoder</small> | yes<br><small>with wires</small>  | yes<br><small>on PluX</small>   | yes<br><small>on s. pads</small>   | yes<br><small>on s. pads<br/>max 15,000 µF</small>                               | yes<br><small>on PluX<br/>max 15,000 µF</small>                                  | no   | no   | no   | no  | yes<br><small>on s. pads<br/>max 15,000 µF</small>                               |

*\*) Decoder MN160, MN170, MN180 und MN300 (jeweils alle Typen) sind NICHT mfx-fähig; dadurch sind die kleinen Abmessungen möglich.*



## 2 Technical Data, schematics, operation with mfx

### Technical data for all MS sound and MN non-sound decoders:

|  |   |
|--|---|
| Track voltage on the rail in digital mode .....  | 10 V - 35 V   |
| Allowable track voltage H0 and large-scale decoders.....   | 7 V - 35 V  |
| Miniature- and Next-Decoders .....   | 7 V - 24 V  |
| Decoder together with StayAlive controller STACO1/STACO2/STACO3  | 12.5 V - 18 V   |
| The dielectric strength of the decoder also allows higher track voltages for a very short time (< 1 sec) |   |
| Operating temperature .....  | - 20 to 80 °C   |
| Sound sample memory .....  | 128 Mbit (= 360 sec at 16 bit / 22kHz<br>up to 1440 sec with 8 bit / 11 kHz) *) |
| Resolution of the sound samples and the play back quality .....  | 8 or 16 bit   |
| Sample rate of the sound samples and the playback .....  | 11, 22, 44 kHz  |
| Number of independent sound channels .....   | 16  |

\*) those playback times are all "theoretical"; in praxis, 5% to 20% of the memory are not available, because they are reserved for organization, descriptions, GUI-info, sounds to load later, etc.  
This calculation is based on a maximum sample rate of 22 kHz, because 44 kHz does not provide real improvement to quality.

### Data on the STACO1, STACO2 and STACO3 StayAlive controller (in conjunction with miniature decoder)

|  |                  |
|--|------------------|
| Rail voltage for charging the Goldcaps.....  | 12.5 V - 18 V    |
| Max. permitted rail voltage.....             | 18 V             |
| Constant output voltage.....                 | approx. 10 V     |
| Charging current:                            |                  |
| STACO1: .....                                | max. 45 mA       |
| STACO2 and STACO3 .....                      | max. 25 mA       |
| Time to charge from 0 to 100%:               |                  |
| STACO1, STACO2A and STACO3A.....             | 31.2 s           |
| STACO2B and STACO3B.....                     | 104 s            |
| Discharge current example .....              | 75 mA            |
| Discharge time at discharge current example: |                  |
| STACO1 with 2 resp. 3 Goldcaps .....         | 1.58 s resp. 3 s |
| STACO2A and STACO3A.....                     | 1.22 s           |
| STACO2B and STACO3B.....                     | 3.12 s           |

### Type-dependent technical data of the MS and MN decoders:

See previous chapter "Overview of the types and type-dependent data"

The decoder type can be read out in CV #250 if needed:

|              |            |            |           |            |
|--------------|------------|------------|-----------|------------|
| 1 = MS500    | 2 = MS480  | 3 = MS490  | 4 = MS440 | 5 = MS580  |
| 6 = MS450    | 7 = MS990  | 8 = MS590  | 9 = MS950 | 10 = MS560 |
| 11 = MS001)* | 12 = MS491 | 13 = MS581 |           |            |

|               |             |             |             |             |
|---------------|-------------|-------------|-------------|-------------|
| 120 = MN250** | 121 = MN150 | 122 = MN160 | 123 = MN340 | 124 = MN170 |
| 125 = MN300   | 126 = MN330 | 127 = MN180 |             |             |

\* Fleischmann Beilhack    \*\* planned 5V-Motor-Decoder

### Software Update:

You need a device that can perform updates: **ZIMO MXULF/A** (decoder updating and sound loading device), **ZIMO central command station MX10**, or **Roco digital central Z21**. The new SW version is downloaded from [www.zimo.at](http://www.zimo.at), loaded into a flash drive or sent to the updating device via USB-connection to a computer and ZSP to an updating device, which then executes the actual update via the track input of the decoder.

This is (generally) also the way a sound project is loaded into a ZIMO decoder.

In general, both UPGRADE (the "normal" process, update to newer version) and DOWNGRADE (exceptional cases, update to older version) are possible; BUT: Downgrade of decoders with SW version from 4.200 to SW versions older than 4.200 is NOT possible.

See chapter "10 Software update and sound loading with MXULFA" in this operating manual and MXULF(A) operating manual; especially downgrade limit for SW version 4.200!

### Overload and thermal protection:

The motor and function outputs of ZIMO decoders are designed with lots of reserve capacities and are additionally protected against excessive current draw and short circuits. Cut-outs are encountered if the decoder is overloaded.

---

**Even though the decoder is well protected; it is not indestructible. Please pay attention to the following:**

**Wrong decoder contact:** if, for example, the motor leads have contact to track power or an overload connection between the motor brushes and rail pick-ups, this is not always recognized by the overload protection circuit and could lead to damage of the motor power amplifier or even a destruction of the decoder.

**Unfit or defective motors:** e.g. coil or commutator shorts are not always recognized by their high current consumption, because these are often just short current spikes. So, they can lead to decoder damage including damage to power amplifiers due to long-term exposure.

The power amplifiers of loco decoders (motor as well as function outputs) are not only at risk of overcurrent but also **voltage spikes**, which are generated by motors and other **inductive consumers**. Depending on track voltage, such spikes can reach several hundred volts and are absorbed by special protection circuits inside the decoder. This is why the running voltage shall not be too high, i.e. not higher than intended by the corresponding vehicle.

---

ZIMO decoders are equipped with temperature sensors to measure their own operating temperature. Power to the motor will be turned off once that temperature exceeds 100°C. To indicate this state FA0v and FA0r are on. Motor control will resume automatically after a drop in temperature of about 20°C (i.e. to about 80°C), typically in about 30 seconds.



**MS450P22, MS450P16 Top side (with PluX22, -16)**

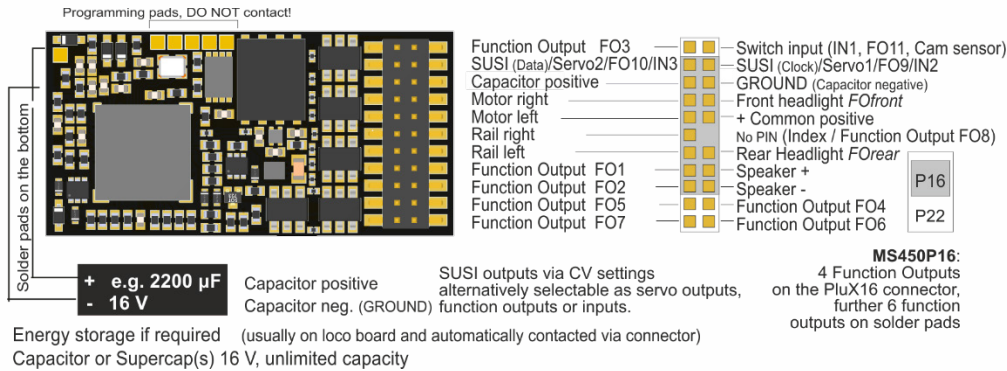

**NOTE: External capacitors on MS440, MS450**  
**▲ Capacitors (Elkos, Supercaps) of any capacity** can be connected to "Capacitor positive" (to ROUND) WITHOUT additional components; they do NOT have to be able to handle full running voltage; 16 V is enough. Prerequisites for the connection for the stay-alive capacitor within the decoder prevent an inrush current too high and enable undisturbed Service Monde programming, software updates, sound loading, also with higher capacities and use the memory the best possible way.

**Servo control lines on SUSI pins (applies to all decoders except large-scale)"**  
 Servo control lines on the SUSI pins are activated by CVs #181, #182). These connections work with a voltage level of 3.3 V (difference to MX decoders where 5 V).  
**Some servos do NOT work with 3.3 V! Possible remedy: lower the supply voltage (normal 5V) to about 4 V; otherwise, only replacement will help; digital servos are better!**

**MS450, MS450R Top side with wires, SOUND**

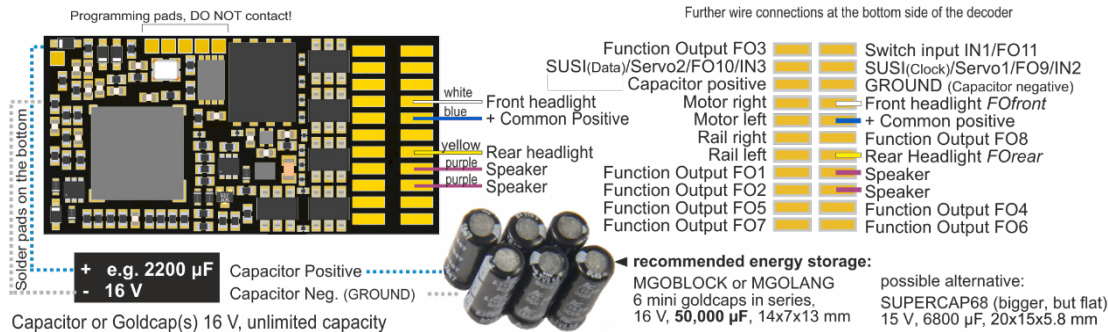

**MS450 all types Bottom side (example with wires)**

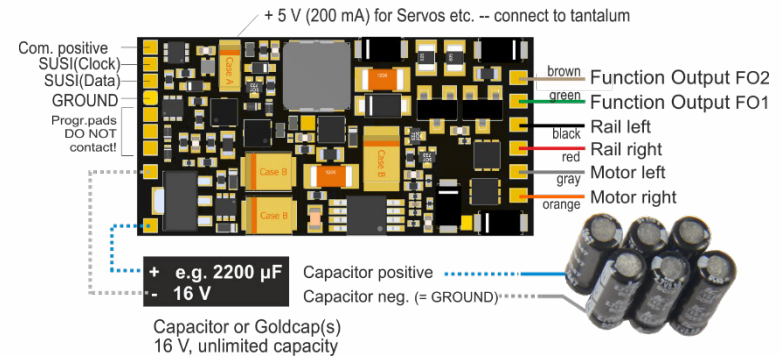

**MS440C, MS440D Top side, with 21MTC, SOUND**

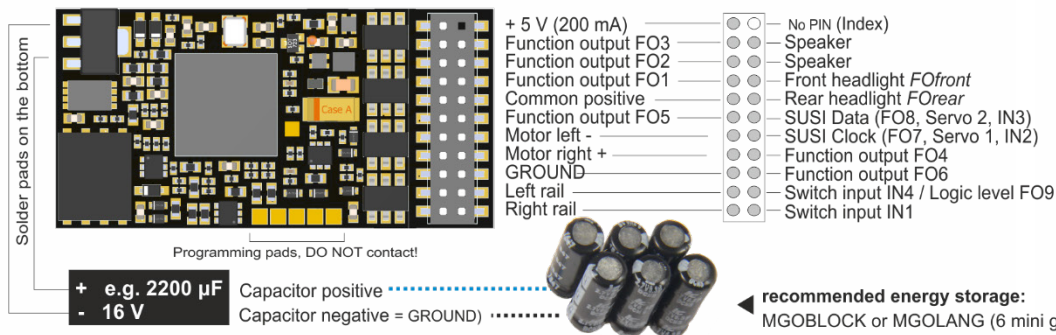

**MS440C, D Bottom side, with 21MTC, SOUND**

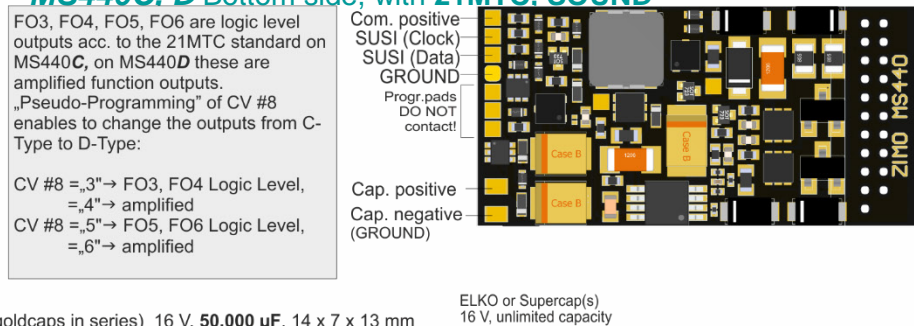





**MN330P22** Top side, with PluX22, NON-SOUND

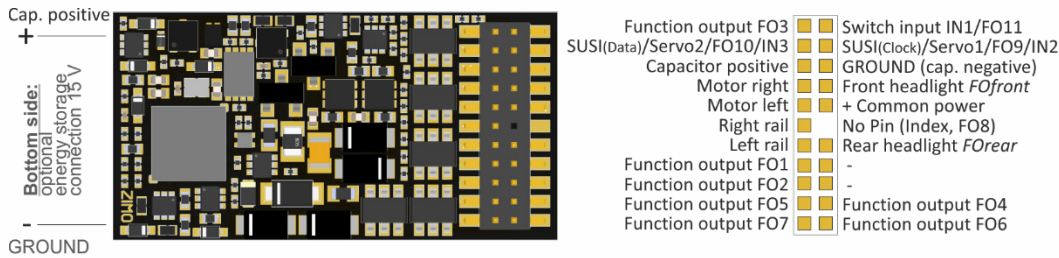

**MN330 all types** bottom side (e.g. with wires), NON-SOUND

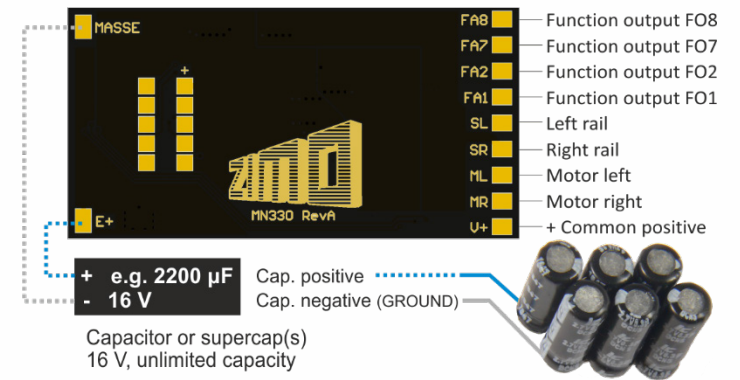

**MN330, MN330R** Top side with wires, NON-SOUND

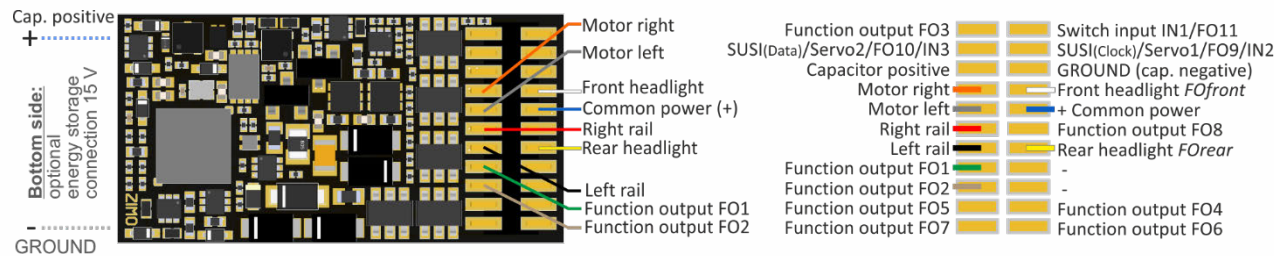

**MN340C, MN340D** Top side, with 21MTC, NON-SOUND

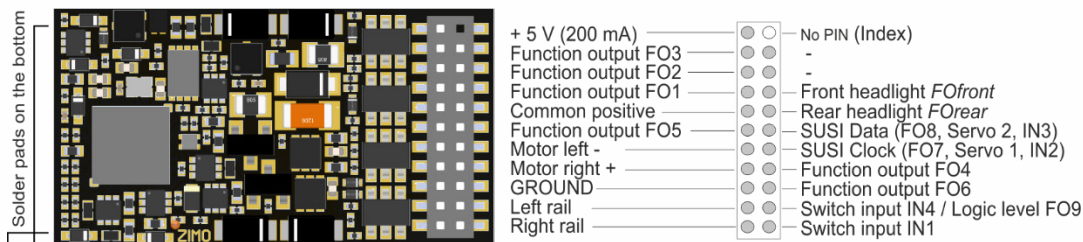

**MN340C, MN340D** Bottom side, NON-SOUND

FO3, FO4, FO5, FO6 are designed as logic level outputs on the MN340C in conformity with the 21MTC standard, and as amplified function outputs on the MN340D. By "pseudo-programming" CV #8, the outputs can be subsequently reconfigured and thus C-type and D-type can be converted into each other:  
 CV #8 = „3" → FO3, FO4 logic level,  
 = „4" → amplified  
 CV #8 = „5" → FO5, FO6 logic level,  
 = „6" → amplified

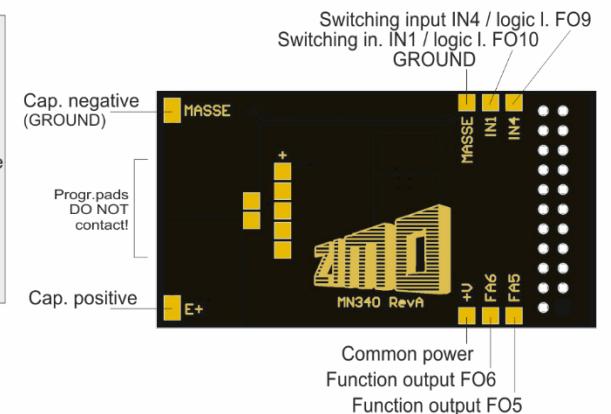

Capacitor or supercap(s)  
16 V, unlimited capacity

+ e.g. 2200 µF  
- 16 V

Capacitor positive  
Capacitor negative = GROUND



◀ **recommended energy storage:** MGOBLOCK or MGOLANG  
(6 mini goldcaps in series) 16 V, 50,000 µF, 14 x 7 x 13 mm



**MS480, MS480R, MS480F** Top side with wires

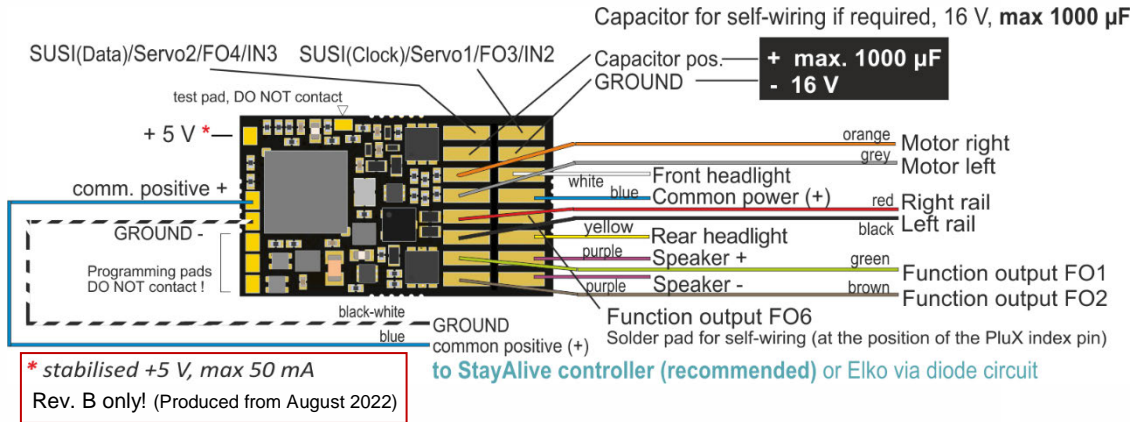

**MN300, MN300R, MN300F** Top Side with wires, NON-SOUND

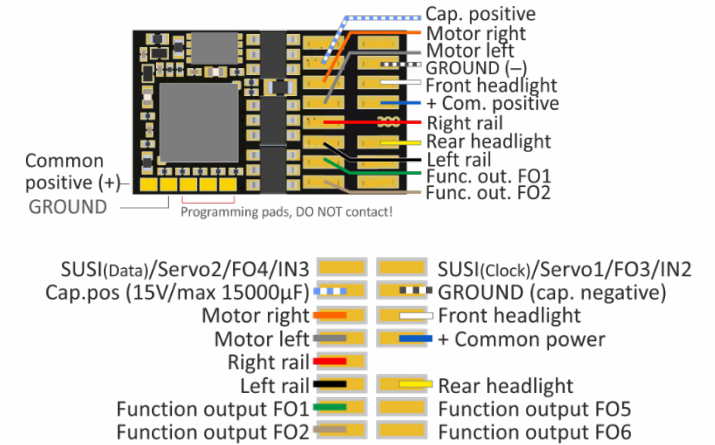

**MS480P16** Top side (with PluX16)

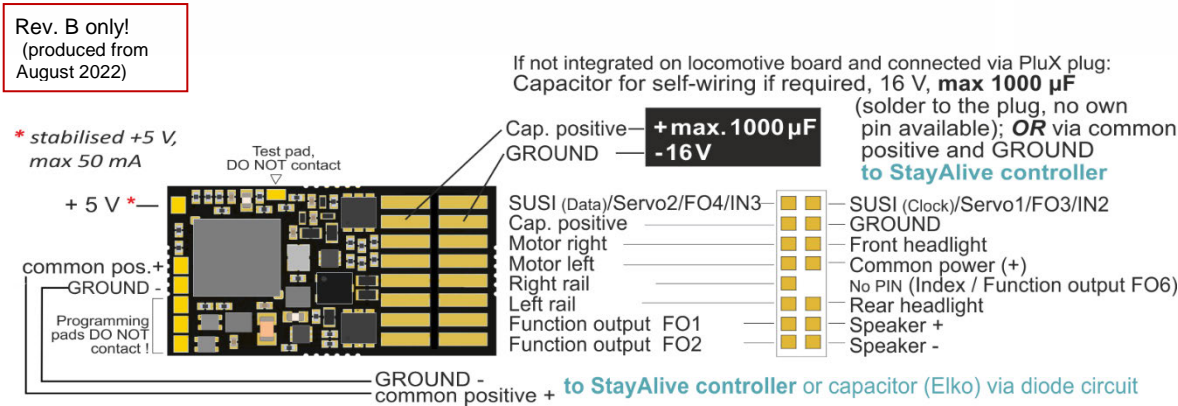

**MN300P16** Top side with PluX16, NON-SOUND

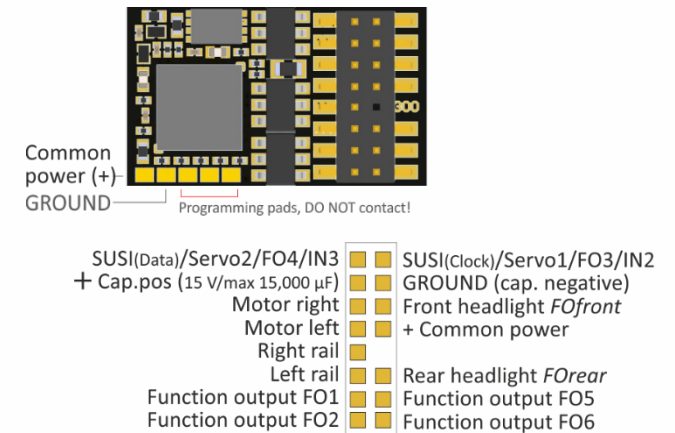

Bottom side **MS480, MS480P16** (drawing shows wired version)

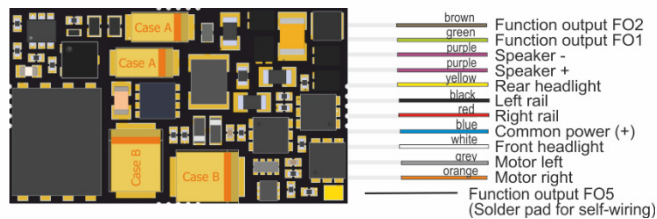

**StayAlive!**

not compatible!!



MGOLANG/MGOBLOCK

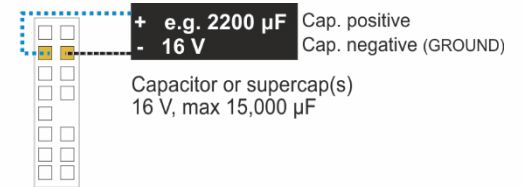

**MS491, MS491R, MS491F** Top side wired, SOUND

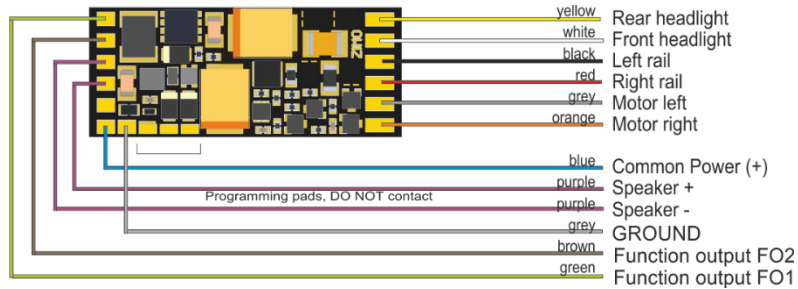

**MS491N, MS491L** NEM 65

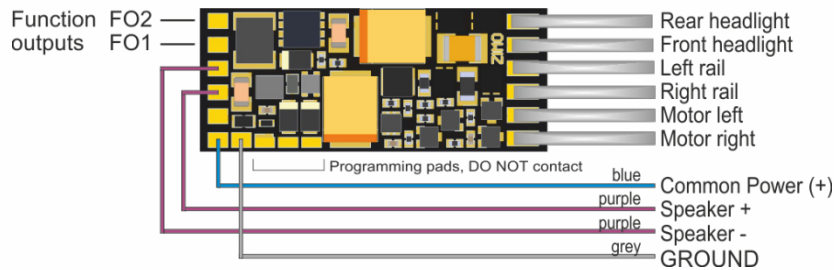

**MS491, ..R, ..F, ..L Bottom side, SOUND**

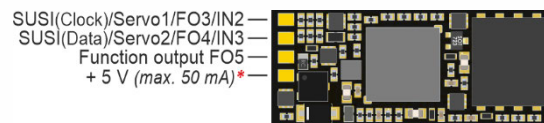

\* Stabilised + 5 V output, max. 50 mA

**ATTENTION:**

In vehicles equipped with a 6-pin NEM MS500N is plugged in, "functions" (lights, cause there is no pin), but hang on the "a an external energy storage (e.g. STACC flicker when the track is dirty ...), but "only on motor and sound. At the same time such an artificial plus pole" hinders the functional safety of ABC.

**POSSIBLE REMEDY:**

The positive poles of the consumers would have to be disconnected from the "artificial plus pole" and connected to the "common plus pole" of the decoder by wire.

**MS500, MS500R, MS500F** Top side with wires, SOUND

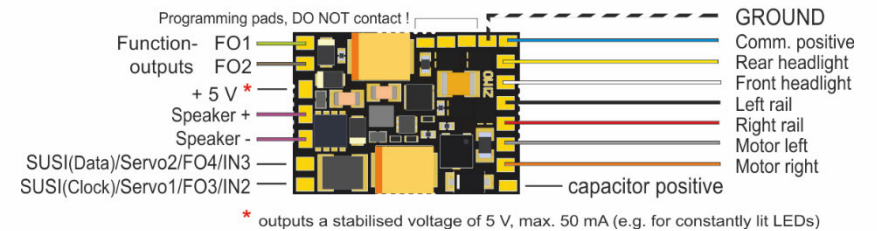

**MS500N** NEM651, SOUND

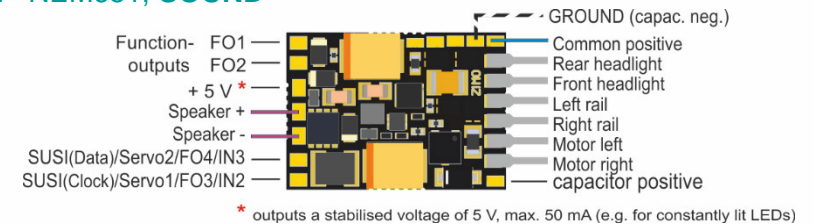

**Energy storage solution with STACO1 or ELKO on the MS500**

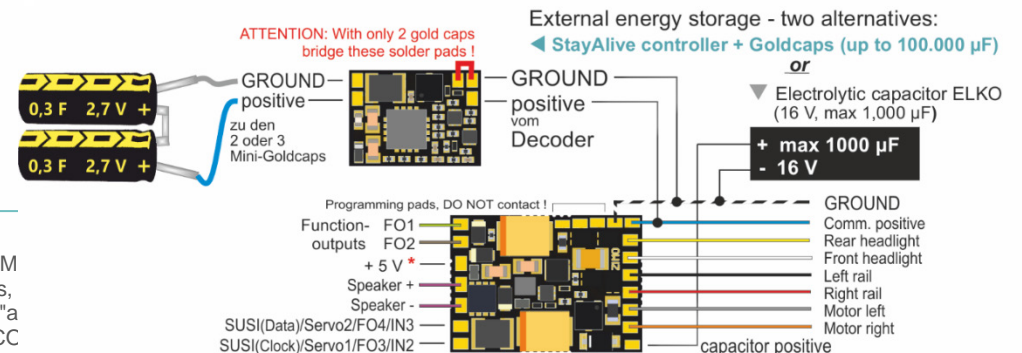



**MN170, MN170R, MN170F** Top side, wired . NON-SOUND

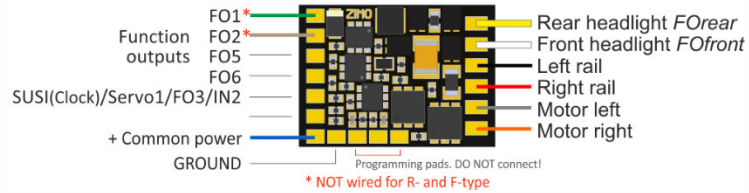

**MN170N** Top side, with NEM 651 . NON-SOUND

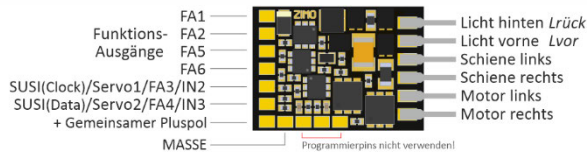

**MN160** Top side, wired / **MN160N** Top side, NEM 651 . NON-SOUND



**MN160, MN160N** Bottom side, NON-SOUND

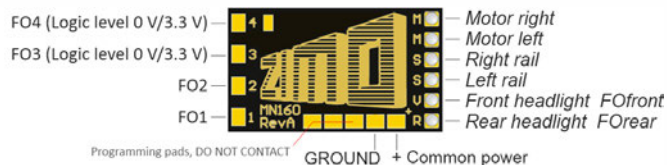

Caution when soldering the soldering points for cables or pins on the reverse side

**MN160L** Bottom side, NEM 651 / Top side, NON-SOUND



Extern. capacitors directly on miniature decoders MS480, MS491, MS500, MN160, MN170

◀ **Elkos with 1000 µF** can be connected to "ELKO Plus" WITHOUT additional components according to the circuit diagrams on this page. They do NOT have to be able to handle full running voltage; **15 V** is enough. However, the capacity must not exceed 1000 µF, which only provides little protection against motor juddering and sound disturbances.

▼ **Bigger capacitors** can be connected instead or additionally (practically without limitation) to "common positive" and GROUND, although, WITH additional components and a dielectric strength suitable for the running voltage (usually 25 V):

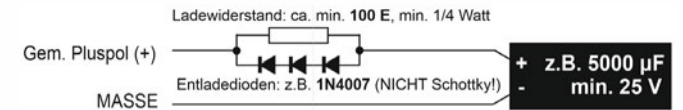

The resistor prevents an inrush current too high, the diodes enable Service mode programming, software updates and sound loading by dropping the voltage despite higher capacities.

External capacitors on miniature decoders over

**StayAlive! - controller STACO1/STACO3**

NOTE: If only 2 gold caps are used bridge these solder pads! NO bridge for three Goldcaps!

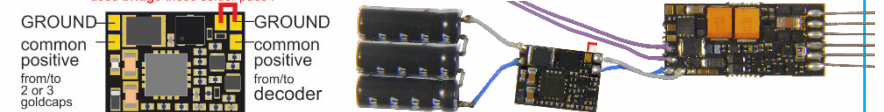

STACO1 10 x 7.3 x 2 mm STACO1 (centre) connected to miniature sound decoder MS490N and 3 miniature Goldcaps in series (scale 1:1) (CAD enlarged)

The StayAlive controller is connected via wires to the solder pads "common positive" and "GROUND" of the decoder (two-pole!).

The STACO1 comes with 3 mini Goldcaps (STACO3: 2 mini Goldcaps) as the actual energy storage, which, connected in series, represent a capacity of **100,000 µF** (STACO3A: 150,000 µF, STACO3B: 500,000 µF). Of course, all 3 should preferably be connected, but it also works with 2 (with about 50 % runtime) if there is a lack of space. The STACO1/STACO3 board contains a step-up voltage converter that sucks the Goldcaps from their fully charged state (8 V if 3 of them; 5.2 V if 2) to their almost fully discharged state (2 V) and delivers a constant voltage of 10 V. This is enough to drive and to supply the sound amplifier (which runs on 5 V) without interruption and without loss of volume.

To avoid overheating, decoders with STACO1 or STACO3 connected may only be operated with a **maximum rail voltage of 18 V**. The wire connections between the controller board and the mini Goldcaps make their local separation

possible, and thus in many cases the accommodation of the StayAlive technology.

**MS581N18** Top side (with Next18)

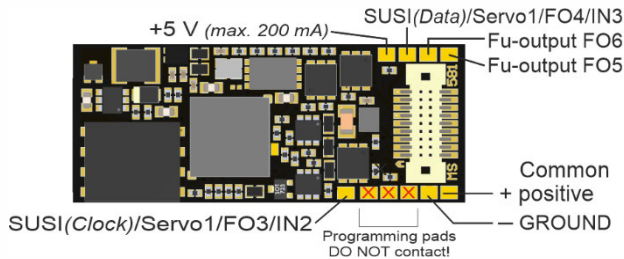

**Next18-S Pin assignment**

|                     |                      |
|---------------------|----------------------|
| Rail left           | Rail left            |
| Motor left          | Front Light FOfront  |
| Fu-output FO2       | Speaker -            |
| SUSI (Data/FO4/IN3) | + Positive           |
| GROUND              | GROUND               |
| + Positive          | SUSI (Clock/FO3/IN2) |
| Speaker +           | Fu-output FO1        |
| Rear Light FOrear   | Motor right          |
| Rail right          | Rail right           |

Bottom side (with optional external extension of the stay-alive capacitor)

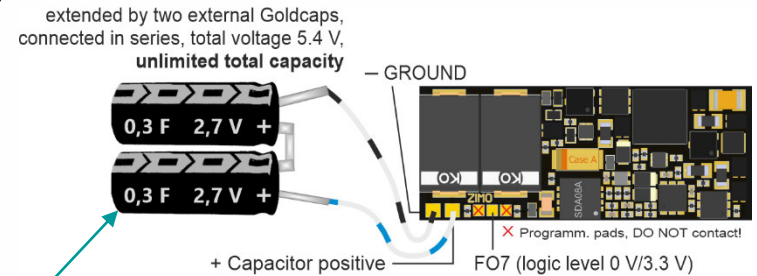
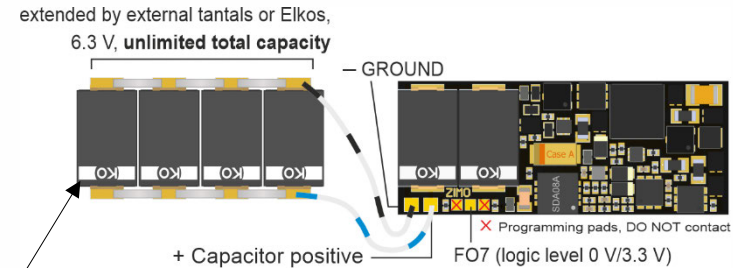

Stay alive time 1 - 2 sec!

Bottom side of type **MS581N18G**

(WITHOUT Tantals on the decoder, but wires to the external stay-alive capacitor). Two connected Goldcaps are delivered with the package, they should be soldered to the open ends of the wires. OBSERVE THE POLARITY (+/-)!

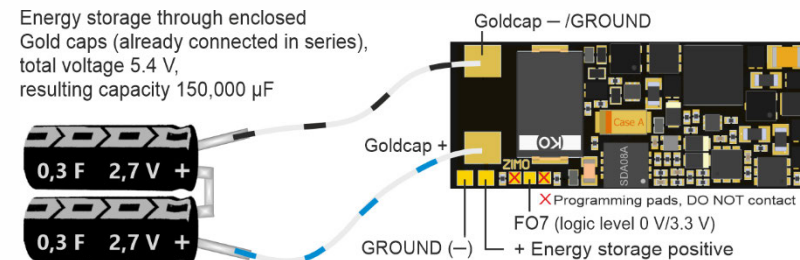

**NOTE: External energy storage with MS580N18**

▲ The "Next decoder" MS580N18 contains a **bigger internal capacity** with a voltage of **5 V**. The Tantal capacitors provide the sound amplifier and the motor (only with 5 V, which is enough for slow driving) in case the track voltage is interrupted. The internal capacity is enough for a **stay-alive** of about **0.1 sec** and thereby prevents cracking noises and gets through short powerless sections.

This internal capacity can be expanded **externally**, either by

- further Tantals of the same type (to be connected via a small wire bridge) or by Elkos. The total capacity is NOT limited, a dielectric strength of the capacitors of 6.3 V is enough, or
- two miniature Goldcaps connected in series (best possibility, if there is enough room, but it can also be put at any other place within the loco connected via wires). Types with 12 x 4 mm (length x diameter) are available as MGOGURT with 2 x 0.3 F at 2.7 V, which enable a **stay-alive** of **1-2 seconds**. Goldcaps or Super caps with higher energy density are to be expected in future.

▲ If (for example because of the lighting) the buffer of the 5 V voltage is not enough, but the full running voltage shall be buffered, capacitors (practically without limitation) can be connected like to every other decoder, to "Gem. Pluspol" (common positive), although, WITH additional components and a dielectric strength suitable for the running voltage (at least 25 V), additionally to the tantals described above or Goldcaps or alone:

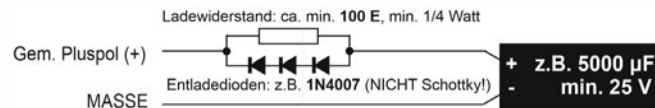

**MS590N18** Top side (with Next18), SOUND

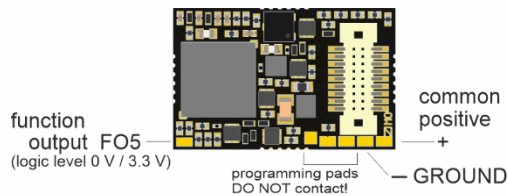

**Next18-S (SOUND) - pin assignment - Next18 (Non-Sound)**

|                           |                           |
|---------------------------|---------------------------|
| Left rail                 | Left rail                 |
| Motor left                | Front headlight FOfront   |
| Function output FO2       | Speaker / Logic level FO6 |
| SUSI (Data/FO4/IN3)       | + Common positive         |
| GROUND                    | GROUND                    |
| + Common positive         | SUSI (Clock/FO3/IN2)      |
| Speaker / Logic level FO5 | Function output FO1       |
| Rear headlight FOrear     | Motor right               |
| Right rail                | Right rail                |

**MN180N18** Top side, with Next18 . NON-SOUND

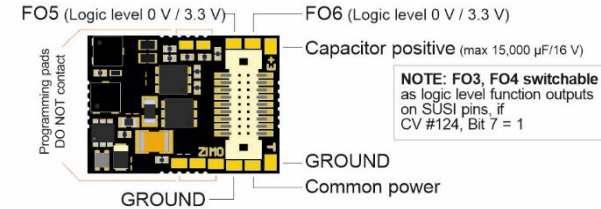

NO connections on **bottom side**, therefore not shown here

NO connections on **bottom side**, therefore not shown here

**NOTE: External energy storage with MS590N18**

Due to the extreme miniaturization, the "Next decoder" MS590N18 does NOT contain provisions to connect an external energy storage directly.

It is possible to connect ELCOs (practically without limitation) to "GEM. Pluspol" (common positive) and ground, although, WITH additional components and a dielectric strength suitable for the running voltage (usually 25 V):

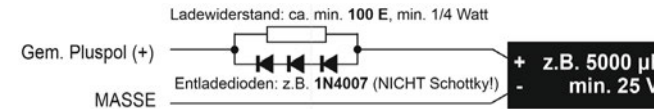

The resistor prevents an inrush current too high, the diodes enable Service mode programming, software updates and sound loading by dropping the voltage despite higher capacities.

External capacitors on miniature decoders over

**StayAlive! - Controller**

**STACO1/STACO3**

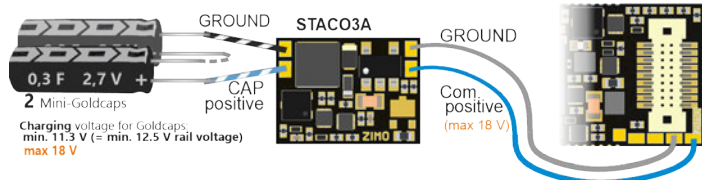

2 mini Goldcaps, STACO3 and Next-Decoder (example MS590N18) in series

The StayAlive controller is connected via wires to the solder pads "common positive" and "GROUND" of the decoder (two-pole!).

STACO3A: 2 mini Goldcaps à 0.3 F/2.7 V, 4 x 12 mm, 150,000 µF;  
STACO3B: 2 mini Goldcaps à 1 F/2.7 V, 6.4 x 9.8 mm, 500,000 µF

The STACO1 comes with 3 mini Goldcaps à 0.3 F/2.7 V, 4 x 12 mm as the actual energy storage, which, connected in series, represent a capacity of 100,000 µF.

Of course, all 3 should preferably be connected, but it also works with 2 (with about 50 % runtime) if there is a lack of space.

The wire connections between the controller board and the mini Goldcaps make their positional separation possible, and thus in many cases the accommodation of the StayAlive technology.

The STACO boards contain a step-up voltage converter that sucks the Goldcaps from their full charge state (8 V for 3 pcs; 5.2 V for 2) to their almost full discharge (2 V) and delivers a constant 10 V voltage. This is enough for driving and for uninterrupted supply of the sound amplifier (runs on 5 V) without volume loss.

**STACO2**

**StayAlive-Controller with Next18-connection**

A Next18 decoder can be plugged on like on an adapter board, the STACO2 then outputs the decoder connections via 13 soldered strands.

The STACO2A set contains 13 soldered wires and 2x mini Goldcaps à 0.3 F/2.7 V, 4 x 12 mm

The STACO2B set contains 13 soldered wires and 2 mini Goldcaps à 1 F/2.7 V, 6.4 x 9.8 mm

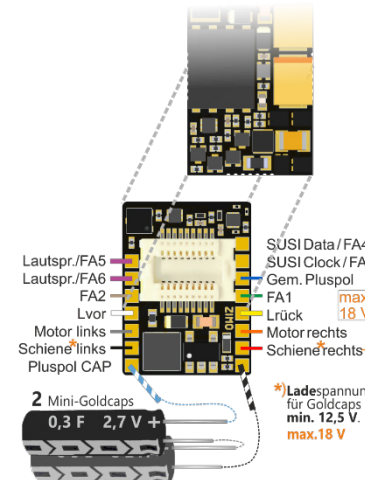

**MS560** Top Side (when plugged into KATO vehicle)

**MS560** top with KATO interface

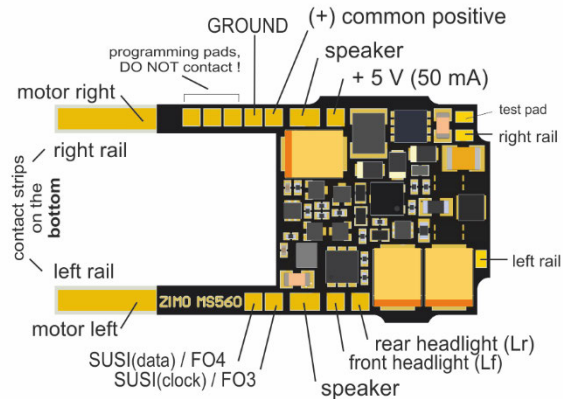

In addition to the actual (main) decoder - in this case the MS560 sound decoder - **the equipment of KATO vehicles** (mostly multiple unit express trains such as ICE-4 or Shinkansen) includes special function decoders for the headlights and interior lighting.

Such are available from the **ZIMO MX decoder series**:

**MX605FL**  
Interior lighting function decoder

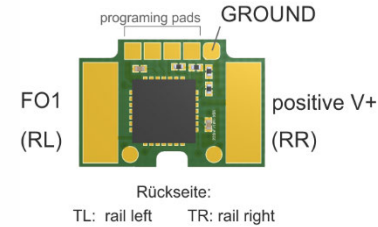

**MX605SL**  
Headlight function decoder

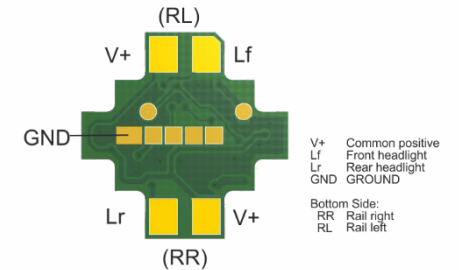

**NOTE: External energy storage to MS560**

▲ The MS560 "KATO decoder" does NOT include provisions for direct connection of external energy storage devices.

ELCOs can be connected (practically without limitation) between "Gem. Pluspol" (Common positive pole) and MASSE (GROUND), but WITH additional components and a dielectric strength suitable for the driving voltage (usually 25 V):

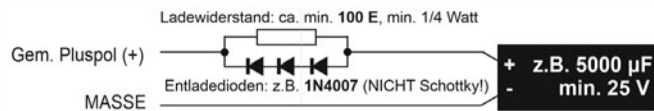

The resistor prevents too high inrush current; the diodes enable service mode programming as well as software update and sound charging despite larger capacities due to the voltage drop.

External energy storage to "KATO-Decoder" MS560 via **StayAlive! - Controller STACO1**

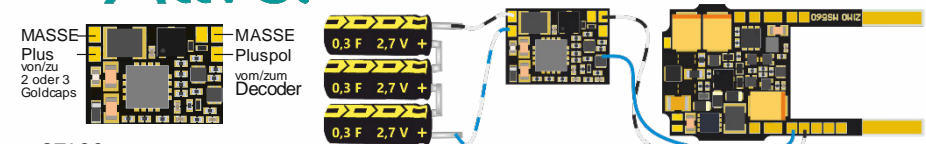

STACO1 10 x 7.3 x 2 mm (CAD 2:1 vergrößert)

STACO1 (Mitte), „KATO-Decoder“ MS560 und 3 mini Goldcaps in Serie geschaltet (Maßstab 1:1)

The StayAlive controller is connected to the terminals (solder pads or wires) "Common positive" and "GROUND" of the decoder (two-pole!).

The STACO1 comes with 3 mini Goldcaps as the actual energy storage, which are connected in series and represent a capacity of 100,000 µF. Of course, preferably all 3 should be connected, but it also works with 2 (with about 50 % runtime) if there is a lack of space. The STACO1 board contains a step-up voltage converter, which sucks the Goldcaps from their full charge (8 V, if 3; 5.2 V, if 2) to their almost full discharge (2 V) and delivers a constant voltage of 10 V. This is enough for driving and for an uninterrupted supply of the sound amplifier (which runs on 5 V) without loss of volume.

Instead of a STACO1, a STACO3 can be used.

**DECODER TYPES NO LONGER IN PRODUCTION**

**MS490, MS490R, MS490F** Top side, wired . SOUND

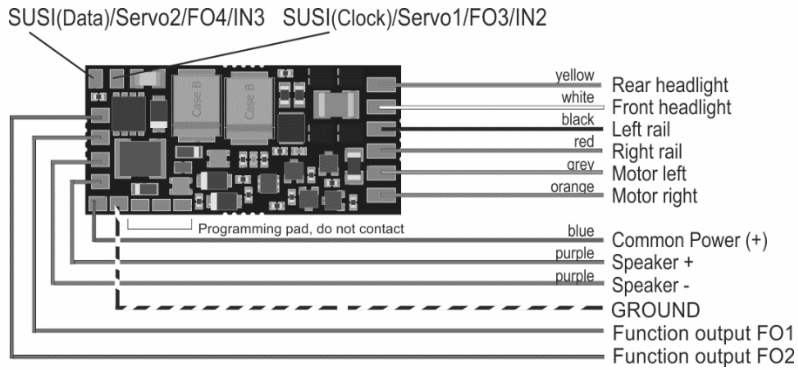

**MS490N, MS490L** Top side, NEM 651 . SOUND

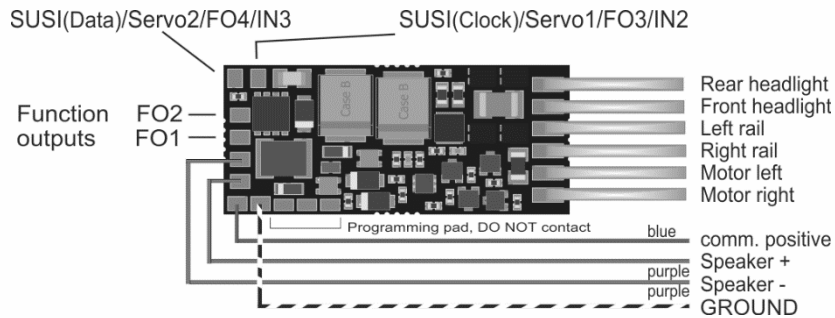

**MS580N18G** Bottom of the version G

Energy storage through enclosed Gold caps (already connected in series). Total voltage 5.4 V, resulting capacitance 150 000 µF

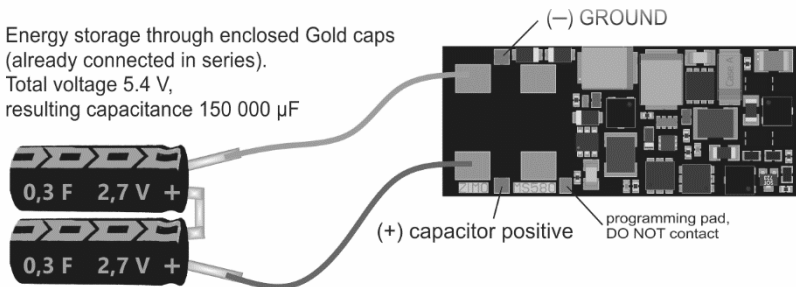

**MS580N18** Top side, Next18 . SOUND

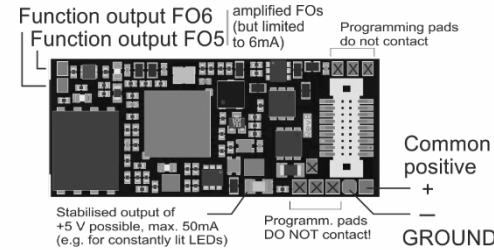

**Next18-S (SOUND) - pin assignment - Next18 (Nicht-Sound)**

|                           |                           |
|---------------------------|---------------------------|
| Left rail                 | Left rail                 |
| Motor left                | Front headlight FOfront   |
| Function output FO2       | Speaker / Logic level FO6 |
| SUSI (Data/FO4/IN3)       | + Common positive         |
| GROUND                    | GROUND                    |
| + Common positive         | SUSI (Clock/FO3/IN2)      |
| Speaker / Logic level FO5 | Function output FO1       |
| Rear headlight FOrear     | Motor right               |
| Right rail                | Right rail                |

**MS580N18** Bottom side, with opt. external extension of the energy storage unit

extended by external tantals or capacitors, Internal tantals (6.3 V)

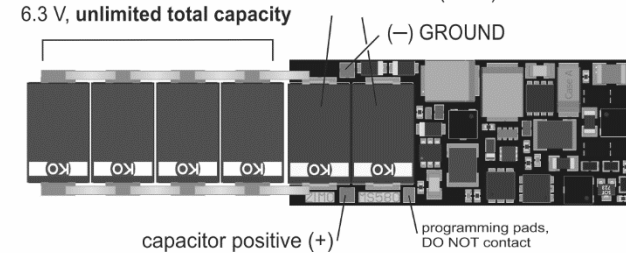

extended by external gold caps in series total voltage 5,4 V, unlimited total capacity

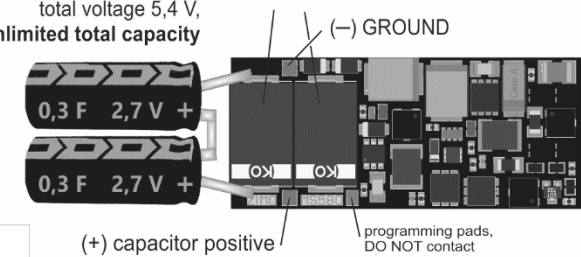

(WITHOUT tantals on decoder, but wires to external energy storage. Two connected gold caps are included in the package, these can be soldered to the open ends of the wires. NOTE POLARITY!)





MS950 (Rev.B)

- function outputs
- FO1 ○ ○ front headlight
  - FO2 ○ ○ rear headlight
  - FO3 ○ ○ motor right (M+)
  - FO4 ○ ○ motor left (M-)
  - FO5 ○ ○ right rail
  - FO6 ○ ○ left rail
  - FO7 ○ ○ common pos. (+)
  - FO8 ○ ○ fan V2
  - FO9 ○ ○ fan V1

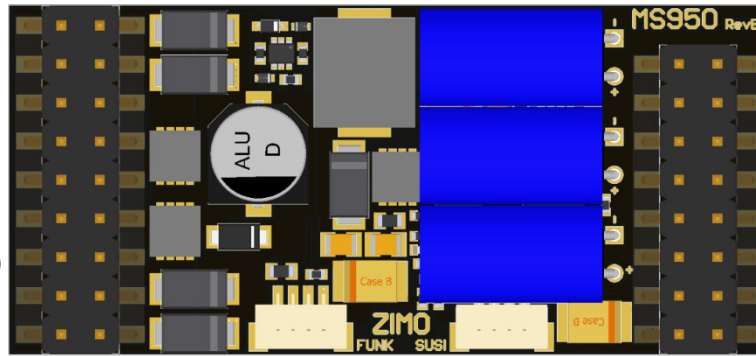

- switch input IN4 ○ ○ switch input IN3
- switch input IN2 ○ ○ switch input IN1
- SUSI-2 data / servo-4 / FO11 ○ ○ SUSI-2 clock / Servo-3 control line / FO12
- servo-2 control line ○ ○ servo-1 control line
- speaker LS2 (A) ○ ○ speaker LS2 (B)
- speaker LS1 (A) ○ ○ speaker LS1 (B)
- FO10 (LL) ○ ○ servo voltage 5 V
- audio voltage 5 V ○ ○ GROUND

wireless connector    SUSI-1 connector

LOKPL950 loco board, suitable for large scale decoder MS950

(shown in smaller scale)

switch input IN4  
switch input IN3  
switch input IN2  
Audio +5 V / IN1  
servo volt. 5V (2x)  
GROUND (2x)  
comm. positive (2x)  
function output 8 / 10  
function output 7 / 9  
fan V2 / V1  
rail left  
rail right  
motor left  
motor right  
rear headlight  
front headlight

SUSI Data  
SUSI Clock  
speaker LS2 +  
speaker LS2 -  
speaker LS1 +  
speaker LS1 -

FO1  
FO2  
FO3  
FO4  
FO5  
FO6

4 three-pin connectors for direct plug-in of servos:  
Servo-1 and -2 are always available; Servos-3 and -4 when the SUSI-1 pins are switched to servo mode (CVs #183, 184).

GROUND 5 V  
SUSI-1 Data or Servo-4  
GROUND 5 V  
SUSI-1 Clock or Servo-3  
GROUND 5 V  
Servo-2  
GROUND 5 V  
Servo-1

MS950 Bottom side (with base plate)

Base plate above the back of the MS950, visible: ELCO Plus and GROUND connector

MS950

- 4A Motor- / Gesamtstrom
- Multiprotokoll: DCC, mfx, MM
- 16 Bit Sound / 11, 22, 44kHz / 16 Kanäle
- 2 unabhängige 3 Watt Lautsprecher-Ausgänge
- 11 verstärkte Ausgänge / 1 LL-Ausgang
- 4 Servo-Steuerpins / +5V Niederspg.
- 2 Raucherzeuger-Ausgänge
- 2 unabhängige SUSI / 1 Stecker für Funk
- 4 Schalteingänge
- 1 Gyro- und Beschleunigungssensor
- 3 interne „Stay-Alive“ Goldcaps

ELCO plus  
GROUND

← Elko Plus  
← Masse

Susi1 Stecker

Funk Stecker



MS990L Top Side

The second poles of the smoke fans connected to the fan outputs (V1, V2) must be connected to a GROUND pin (NOT to common positive).

- fan V2
- fan V1
- speaker LS2 (A)
- speaker LS2 (B)
- low voltage 10 V
- low voltage 5 V
- function output FO7
- function output FO8
- function output FO9
- function output FO10
- function output FO11
- function output FO12
- low voltage variable
- function output FO13

The respective positive poles of the consumers connected to the function outputs can be connected to common positive, low voltage 5V, low voltage 10V, or to variable low voltage (adjustable by CV) as required.

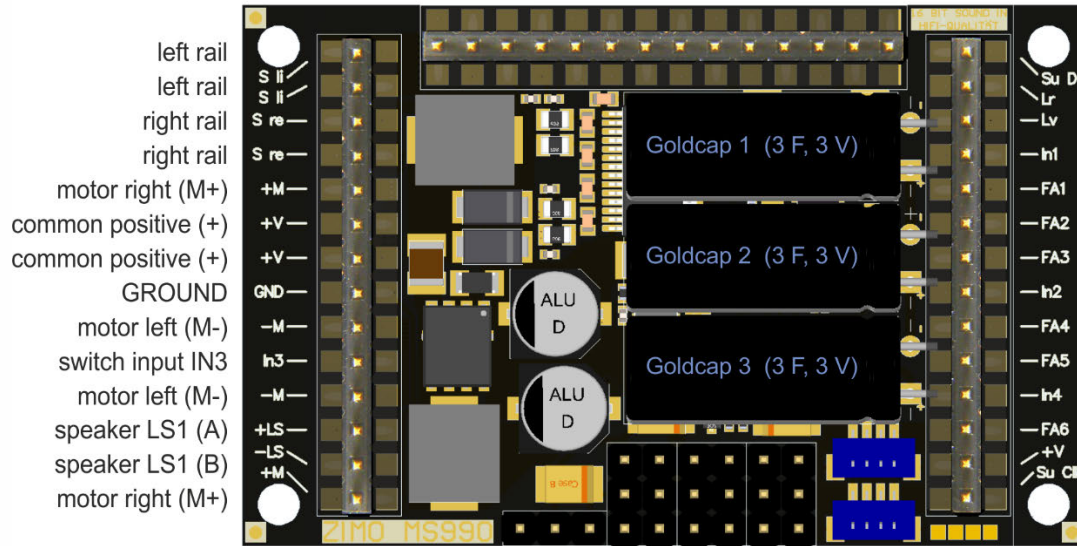

- left rail
- left rail
- right rail
- right rail
- motor right (M+)
- common positive (+)
- common positive (+)
- GROUND
- motor left (M-)
- switch input IN3
- motor left (M-)
- speaker LS1 (A)
- speaker LS1 (B)
- motor right (M+)

- SUSI-2 data/servo-8 ctr.l.
- rear headlight (= Lrück)
- front headlight (= Lvor)
- switch input IN1
- function output FO1
- function output FO2
- function output FO3
- switch input IN2
- function output FO4
- function output FO5
- switch input IN4
- function output FO6
- common positive (+)
- SUSI-2 clock/servo-7 ctr.l.

MS990 is produced and shipped in the following basic variations:

as **MS990L** with 3 x 14-pole pin connector (see figure left), the outmost pins on the left and the right pin connectors were mainly added for a 2 x 14 pin Märklin interface; the connectors are otherwise used rarely (due to the doubled pins or a second SUSI interface).

as **MS990K** with 2 x 12 and 1 x 12 pole screw terminals (as mentioned above, the outmost connections on the left and on the right side are not needed).

**Special editions** (Mixture of pin connectors and screw terminals, or editions with less outputs) can be produced on demand.

Due to the higher currents at the rail and motor connections in some applications, these are each led out twice. This is a safety measure that is rarely needed in practice.

- capacitor positive
- GROUND
- low voltage 5 V
- servo-1
- servo-2
- servo-3
- servo-4
- servo-5
- servo-6
- wireless connector
- SUSI-1 connector

The loco board for the large scale decoder MS990L (shown in smaller scale)

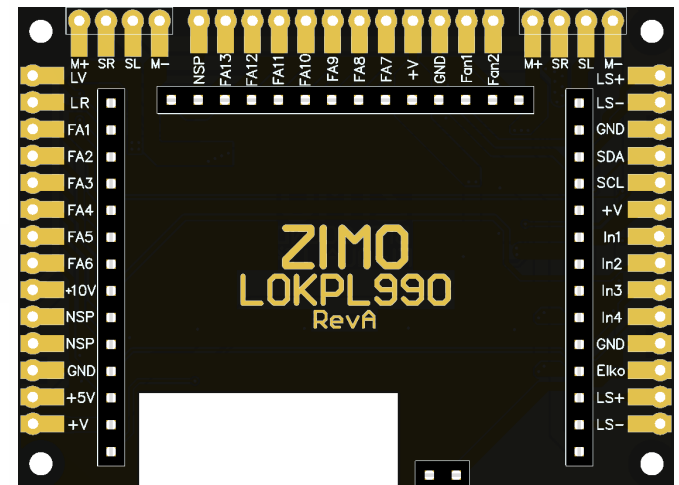



Schematic MS990K

The second poles of the smoke fans connected to the fan outputs (V1, V2) must be connected to a GROUND pin (NOT to common positive).

- fan V2
- fan V1
- speaker LS2 (A)
- speaker LS2 (B)
- low voltage 10 V
- low voltage 5 V
- function output FO7
- function output FO8
- function output FO9
- function output FO10
- function output FO11
- function output FO12
- low voltage variable
- function output FO13

The respective positive poles of the consumers connected to the function outputs can be connected to common positive, low voltage 5V, low voltage 10V, or to variable low voltage (adjustable by CV) as required.

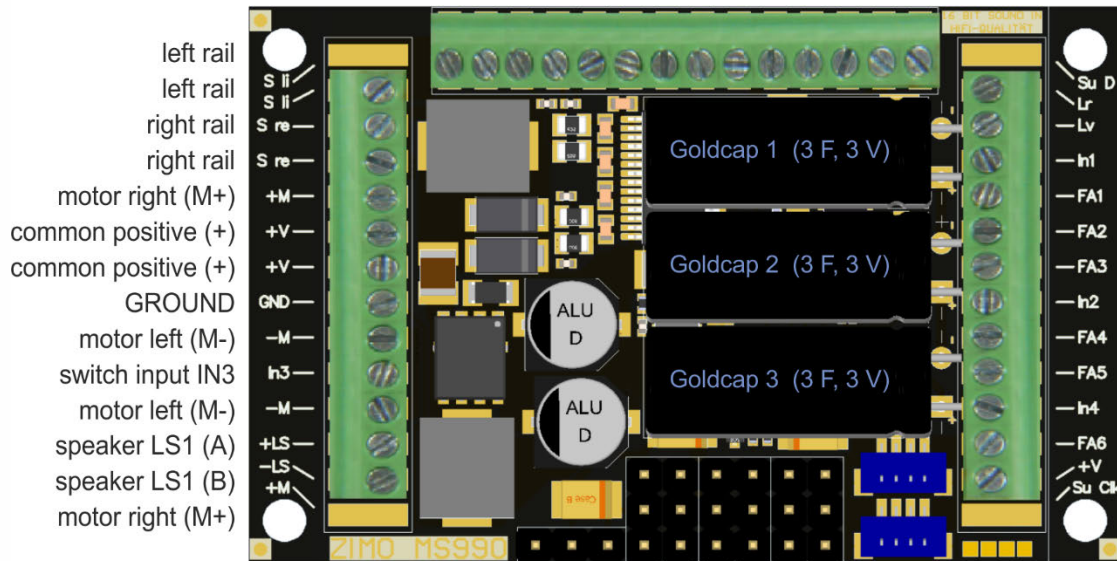

- left rail
- left rail
- right rail
- right rail
- motor right (M+)
- common positive (+)
- common positive (+)
- GROUND
- motor left (M-)
- switch input IN3
- motor left (M-)
- speaker LS1 (A)
- speaker LS1 (B)
- motor right (M+)

- SUSI-2 data/servo-8 ctr.l.
- rear headlight (= Lrück)
- front headlight (= Lvor)
- switch input IN1
- function output FO1
- function output FO2
- function output FO3
- switch input IN2
- function output FO4
- function output FO5
- switch input IN4
- function output FO6
- common positive (+)
- SUSI-2 clock/servo-7 ctr.l.

**NOTE:**  
External energy storage on MS990

Generally, the internal capacitor (3 Goldcaps and a step-up transformer to produce full running voltage from the 3 x 3 V Goldcaps) is sufficient for almost all applications.

Nevertheless, there is a possibility to connect an additional capacitor between "ELKO Plus" (capacitor positive) and ground: External capacitor need a dielectric strength of up to 16 V, the capacity is unlimited - we recommend the ZIMO products GOLMRUND and GOLMLANG, for example. Connecting "normal Elkos/capacitors" would be unnecessary (although the connection is named "ELKO"), because they do not provide a significant contribution compared to the internal stay-alive capacitor.

Due to the higher currents at the rail and motor connections in some applications, these are each led out twice. This is a safety measure that is rarely needed in practice.

- capacitor positive
- GROUND
- low voltage 5 V
- servo-1
- servo-2
- servo-3
- servo-4
- servo-5
- servo-6
- wireless connector
- SUSI-1 connector
- testpads, DO NOT contact !
- 3 pole servo plugs ( control line, 5 V, ground)

The base of the large-scale decoder MS990 ▶

(shown in smaller scale)

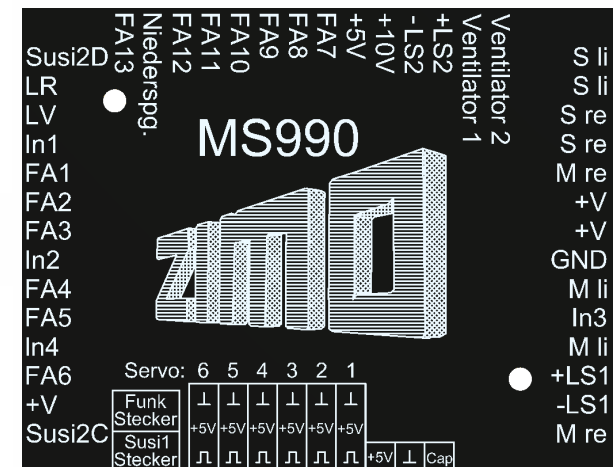

## Mfx operation with the Märklin Central Station 3

The pictures below are **screenshots** of the **Märklin Digital Central CS3** (via the corresponding web browser) and show the registration process of a ZIMO MS sound decoder. The decoder type does not matter in this case; of course, it has to be mfx-able (i.e. NOT MS490, MS590).

The MS decoder in this example has loaded the sound project of the European Steam/Diesel Collection, which is typical for ZIMO shipment and reproduces sounds of BR50, BR70, BR 03.10 (Steam locos) or a BR 211 (Diesel).

The “sound collection” (i.e. more than one loco in a project) is a ZIMO specialty and therefore not especially supported by Märklin command stations; the usage, although - including the selection of a loco type - is still possible, using a trick. This is also described in the pictures.

In case of a “normal” sound project (for a single loco), the usage of the MS decoder is even easier: The part starting with “Selecting a loco type” is not needed.

### NOTE concerning the allocation of a loco picture:

Currently and for the time being, i.e. until the implementation of another registration procedure within the Central Station, which is confirmed by Märklin and will consider loco pictures for non-Märklin decoders, there are **the following possibilities**:

- After successful registration (if “???” is shown instead of a picture), you can select a picture from the collection of pictures within the Central Station (see CS instruction manual).
- Sometimes, a picture is automatically selected (by matching the name).
- If you want to use your own picture, you can load it into the Central Station and can then select it from one of the existing pictures within the collection (see CS instruction manual, chapter “Importing Locomotive Images Using the Web Browser”.



In this example: first there was no loco on the tracks.

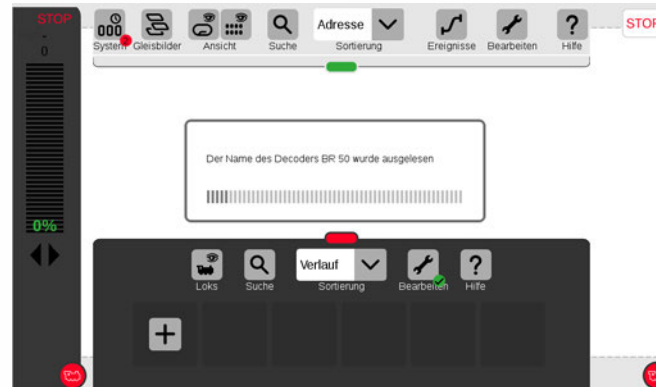

The decoder (loco) is positioned on the tracks, registration begins...



... and is followed by reading out decoder data.

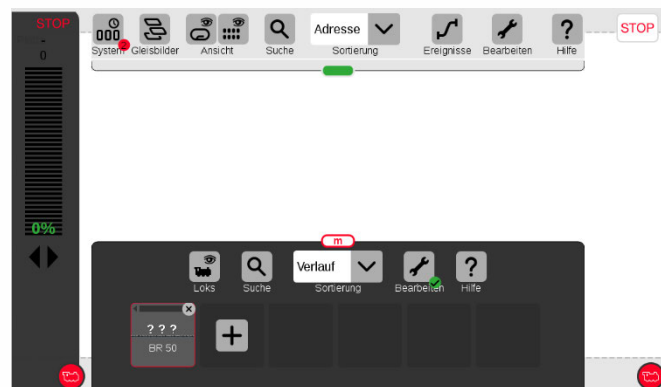

The registration was successful; loco name (in case of a sound collection: name of the first loco type, i.e. “BR 50”) is displayed. However, no picture is displayed. Instead “???”. **NOTE** see above!

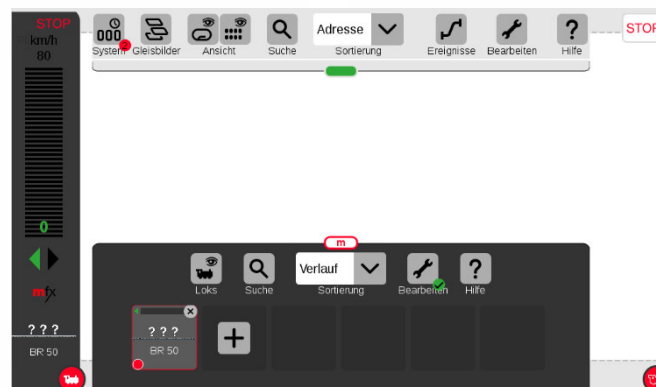

By activating the red loco symbol, the registered loco is taken over by the controller.

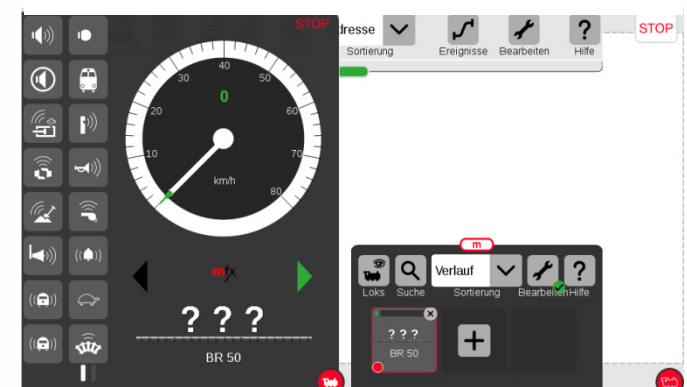

After enlarging the window with the controller bar, speedo and function symbols are displayed (the symbols were selected when registering from the decoder). **The loco can be driven with the regulator knob.**

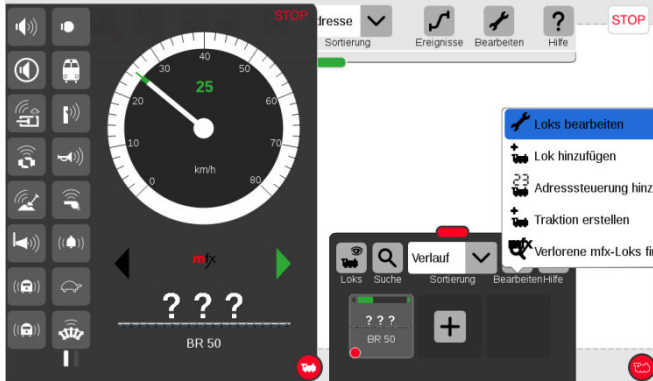

Activating the "screwdriver" button opens...

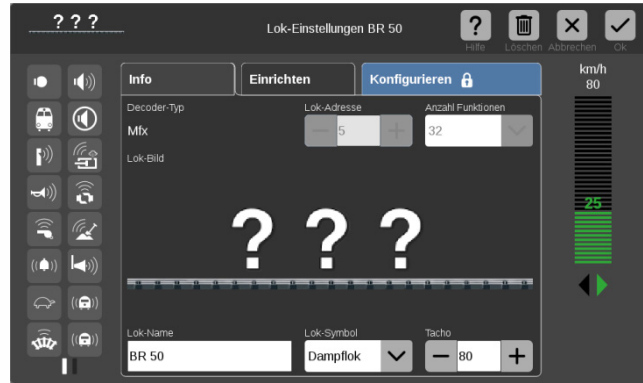

... the processing plane, where with the button "configuration"

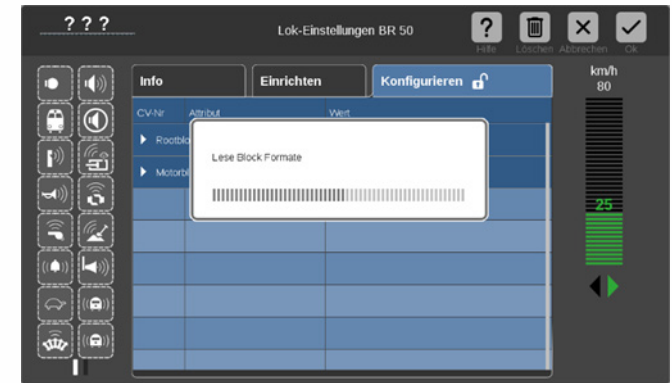

... the "blocks" (i.e. groups of configurations) are read out and opened by the decoder (root block, motor block, formats, sounds, ...).



For example: in "Formats" you can configure the AC-analog operation.

If it is a ZIMO MS decoder with a "normal sound project" (i.e. NO collection)...

... the parameters described on the right "SX1..." do not appear.



**Loco type selection,**

**If it is a ZIMO MS decoder with a loaded "sound collection": ...**

... the parameters "SX1 configuration" and "SX1 address" are displayed when reading out the address. This does not mean that the ZIMO decoder can be driven with Selectrix (ZIMO does not support this format), but the parameters "SX1 address" is **misused to select the loco type** from the sound collection (in DCC operation this is configured with CV #265).

In the example above, the previously displayed "1" is overwritten by "101", i.e.: switch to BR 211, which is stored as number "101" in the sound collection.

After entering the new value, the decoder automatically resets and is, therefore, ready to register as Diesel loco BR 211, as soon as the registration is started by the Central Station.



The steam loco BR50 registered with the system has to be deleted (to do so, there are a few possibilities in the Central Station).

After confirming the security question (see picture above), the decoder is registered automatically, but as "BR 211".

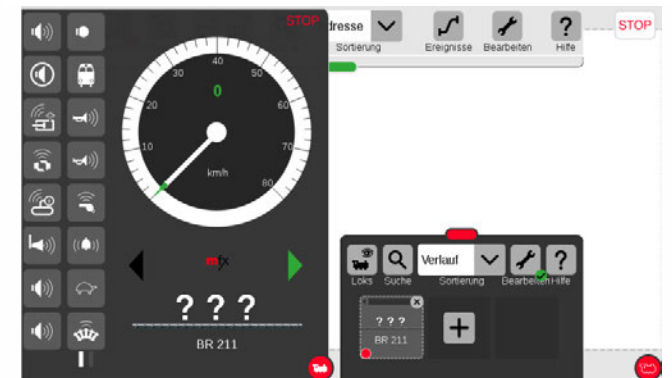



**3 CVs in DCC operation**

**3.1 Basic Configuration**

| CV  | Denomination  | Range                  | Default   | Description  |
|-----|---|------------------------|---|--|
| #10 | Motorola Subsequent addresses   | 0-3                    | 0   | Decimal:<br>0= No Subsequent address<br>1= One Subsequent address for F5-F8<br>2= Two Subsequent addresses for F5-F12<br>3= Three Subsequent addresses for F5-F16  |
| #12 | Operating modes   |                        | 127   | Bit 0 - DC analog 0 = disabled 1 = enabled<br>Bit 2 - DCC NOT deactivatable 1 = enabled<br>Bit 4 - AC analog 0 = disabled 1 = enabled<br>Bit 5 - MM 0 = disabled 1 = enabled<br>Bit 6 - mfx 0 = disabled 1 = enabled<br>Programming CV #12 = 0 (all bits 0) is NOT executed (because the decoder would get un-addressable)   |
| #27 | BRAKING MODES:<br><br>Position-dependent Stopping ("before a red signal") or driving slowly by "asymmetrical DCC signal" ("Lenz ABC")<br><br>See chapter "3.10 Stop in front of a red signal and driving slowly by "asymmetrical DCC-Signal" stops (Lenz ABC)... "<br>or "ZIMO HLU" (see chapter "3.9 ZIMO "signal-controlled speed influence" (HLU)")<br><br>Automatic stopping by DC brake section ("Märklin brake section") see chapter "3.11 DC Brake Sections, "Märklin brake mode"" |                        | 0 = ABC not active, HLU active, other brake sections not active | Bit 0 <u>and</u> Bit 1 = 0: ABC not activated; no stopping<br>Bit 0 = 1: Stops are initiated if the voltage in the right rail (in direction of travel) is higher than in the left rail. This (CV #27 = 1) is the usual ABC application)<br><br>Bit 1 = 1: ABC stops are initiated if the voltage in the left rail (in direction of travel) is higher than in the right rail.<br><br>If Bit 0 <u>or</u> Bit 1 = 1 (only one of the two bits is set): Stopping is directional, i.e. only in direction of travel to the signal, travelling in opposite direction has no effect.<br><br>Bit 0 <u>and</u> Bit 1 = 1: Stops are independent of direction of travel. See chapter "3.10 Stop in front of a red signal and driving slowly by "asymmetrical DCC-Signal" stops (Lenz ABC)..."<br><br>Bit 4 - DC braking section, if polarity is reversed<br>0 = disabled 1 = enabled<br><br>Bit 5 - DC braking section, if polarity is equal to direction of travel<br>0 = disabled 1 = enabled<br><br>Bit 4 <u>and</u> Bit 5 = 1: stopping when DC voltage (e.g. by a diode) independent of the polarity ("Märklin brake section") |
| #28 | RailCom Configuration   | 0, 1, 2, 3, 65, 66, 67 | 3 resp. 67 (for Bit 6)  | Bit 0 - RailCom Channel 1 (Broadcast)<br>Bit 1 - RailCom Channel 2 (Data)<br>Bit 6 - High voltage RailCom (large scale decoders onl.)<br>for all Bits: 0 = OFF 1 = ON  |
| #29 | Basic Configuration   | 0 - 63                 | 14 = 0000 1110<br>Bit 3 = 1 (RailCom is activated)              | Bit 0 - Train direction:<br>0 = normal, 1 = reversed<br>Bit 1 - Number of speed steps:<br>0 = 14, 1 = 28/128 speed steps<br>Bit 2 - automatic change to analog operation<br>0 = disabled 1 = enabled   |

| CV   | Denomination                                       | Range   | Default   | Description   |
|------|--|---------|---|---|
|      |  |         | and Bits 1,2 = 1 (28 or 128 speed steps and automatic analog operation enabled) | Bit 3 - RailCom („bi-directional communication")<br>0 = deactivated 1 = activated<br>Bit 4 - Individual speed table:<br>0 = off, CVs #2, #5 and #6 are active.<br>1 = on, according to CVs #67 - #94<br>Bit 5 - Decoder address:<br>0 = primary address as per CV #1<br>1 = ext. address as per CVs #17 & #18                     |
| #153 | Time limit of the continuation without rail signal | 0 - 255 | 0   | 0: Feature not used<br>1 - 255: Time in tenths of a second after which the decoder starts a braking process if there is no more DCC reception via its two track contacts.<br>During the braking process all braking CVs (e.g. CV #4) are considered. Common CV values for CV #153 are either 0 or 10-20 (for 1.0 to 2.0 seconds). |

**NOTE:** The default values on sound decoders are overwritten by the loaded sound project. The program ZSP (ZIMO Sound Programmer), however, provides the here defined default values, in case the values set by the sound project are not wanted. During updates, differences between ZSP and the default values given here can occur.

**3.2 Decoder-ID, Load-Code**

| CV                     | Denomination  | Range     | Default | Description  |
|------------------------|---|-----------|---------|--|
| #250, #251, #252, #253 | Decoder-ID, thereof<br><b>CV #250 = Decoder-Type</b><br>(See chapter 2 schematics, operation with mfx)<br>CV #251, CV #252 and #253 = serial number | Read only | -       | The decoder ID (serial number) is automatically entered during production: The first byte and half of the second byte denotes the decoder type; the rest contain a serial number.<br><br>The decoder ID is primarily used for automatic address assignment when an engine is placed on the layout track as well as in combination with the "load code" for "coded" sound projects (see CVs #260 - #263). |
| #260, #261, #262, #263 | "Load code" for "coded" sound projects  | -         | -       | New ZIMO sound decoders can be ordered for an additional small fee with a "load code" pre-installed, which entitles the user to install "coded" sound projects of a selected sound bundle. The load code can also be purchased and installed by the user at a later date: see <a href="http://www.zimo.at">www.zimo.at</a> .   |



### 3.3 Manufacturer ID, SW version

| CV            | Denomination  | Range   | Default                 | Description   |
|---------------|---|---|-------------------------|---|
| #8            | <p>Manufacturer ID<br/>and<br/>HARD RESET<br/>by CV #8 = „8“<br/>or CV #8 = 0</p>   | <p>Read only<br/>always shows "145"<br/>for ZIMO ID<br/><br/>Pseudo-programming<br/>see descr.<br/>on the right</p> | <p>145<br/>(= ZIMO)</p> | <p>Reading out this CV always result in "145" (10010001), the number issued for ZIMO by the NMRA.</p> <p>This CV is also used for various resetting processes with the help of Pseudo-Programming.</p> <p>"Pseudo programming" means that the entered value is not really stored, but rather used to start a defined action.</p> <p>CV #8 = "3" → 21MTC decoder FO3, FO4 logic-level<br/>CV #8 = "4" → 21MTC decoder FO3, FO4 normal<br/>CV #8 = "5" → 21MTC decoder FO5, FO6 logic-level<br/>CV #8 = "6" → 21MTC decoder FO5, FO6 normal<br/><b>CV #8 = "8" → HARD RESET (NMRA standard);</b><br/>all CVs return to the last active <b>CV set or sound project</b>, or (if no such set was active before) the default values listed in this CV table.</p> <p>CV #8 = "0" → NOT recommended (service purp. only)<br/>Default values of the CV table</p> |
| #7            | <p>SW version number<br/>Also see CV #65<br/>Sub-Version number<br/>and<br/>Auxiliary procedure for programming via<br/>"Lokmaus-2" and similar<br/>"low level" - systems</p> | <p>Read only</p>  | -                       | <p>CV holds the firmware vers. no currently in the decoder.<br/>CV #7 = number of the "main" version<br/>CV #65 = Sub-version number</p> <p>At the same time this CV is used to make digital systems with limited number space (typ. example: old Lokmaus) usable for programming the decoder by means of "pseudo-programming":</p> <p>Ones digit = 1: Subsequent programming value + 100<br/>= 2: ... + 200</p> <p>Tens digit = 1: Subsequent CV number + 100<br/>= 2: ... + 200</p> <p>etc. = 9: ... + 900</p> <p>Hundreds digit = 0: Revaluation valid for one operation<br/>= 1 ... to power-off</p>  |
| #65           | <p>SW<br/>Sub-Version Number<br/>Also see CV #7 for<br/>Version number</p>  | <p>Read only</p>  | -                       | <p>If there are subversions to the SW version in CV #7, it is read out in CV #65.<br/>The entire SW version number is thus composed of CVs #7 and #65 (i.e. 28.15).</p>   |
| #248,<br>#249 | <p>Bootloader<br/>version and subversion</p>  | <p>Read only</p>  | -                       | <p>Reading out these CVs provides the version and sub-version of the bootloader currently on the decoder (bootloader = program to load the actual software).</p>  |



### 3.4 Vehicle address(es) in DCC mode

Decoders are usually delivered with default **address 3 (CV #1 = 3)**, for DCC as well as the MM (Märklin Motorola) format. With this address the decoder is fully functional but it is recommended to change to a different address as soon as possible.

The address space required for DCC exceeds the range of a single CV, up to 10239 in fact. Addresses higher than 127 are stored in CV #17 and #18. CV #29, Bit 5 is used to select between the short address in CV #1 and the long address in CVs #17/#18.

☞ Most digital systems (except for very old or simple products) automatically calculate the value for the CVs involved and also configure CV #29 Bit 5 to the proper value when writing the address, so that the user does not have to deal with the necessary coding.

| CV        | Denomination            | Range                             | Default                                       | Description   |
|-----------|-------------------------|-----------------------------------|---|---|
| #1        | Locomotive address      | DCC:<br>1 - 127<br>MM:<br>1 - 255 | 3   | The "short" vehicle address (DCC, MM)<br>In case of DCC operation:<br>Primary address as per CV #1 is only valid, if CV #29 (basic configuration), Bit 5 = 0.<br>Otherwise, the address per CVs #17 & #18 is valid, i.e. if CV #29, Bit 5 = 1.  |
| #15 + #16 | Decoder Lock            | 0 - 255<br>0 - 255                | 0<br>0  | The decoder lock is used to access the CVs of several decoder with identical address separately.<br>The CVs #16 of each decoder are programmed to different values before installation. If necessary, the CV #15 of this decoder is reprogrammed to the value of "its" CV #16 > all CVs addressable.<br>CV #15 and #16 = 0: Decoder is not locked.  |
| #17 + #18 | Extended (long) address | 1 - 10239                         | 192<br>128                                    | The long ("extended") DCC address applies to addresses >127.<br>The loco address per CVs #17 & #18 is valid, if CV #29 (basic configuration), bit 5 = 1.  |
| #29       | Basic configuration     | 0 - 63                            | 14 = 0000 1110<br>Bit 5 = 0 ("short" Address) | Bit 0 - Train direction:<br>0 = normal, 1 = reversed<br>Bit 1 - Number of speed steps:<br>0 = 14, 1 = 28/128 speed steps<br>Bit 2 - automatic change to analog operation<br>0 = disabled 1 = enabled<br>Bit 3 - RailCom („bidirectional communication")<br>0 = deactivated 1 = activated<br>Bit 4 - Individual speed table:<br>0 = off, CVs #2, #5 and #6 are active.<br>1 = on, according to CVs #67 - #94<br>Bit 5 - Decoder address selection:<br>0 = primary "short" address as per CV #1<br>1 = "extended" address per CVs #17 & #18 |

### Decoder-controlled consisting (a.k.a. "Advanced consisting" according to NMRA)

The combined operation ("consist") of two or more locomotives (mostly coupled mechanically) with the same speed can be managed by

- the digital system (common practice with ZIMO systems, without changing any CVs of the decoder) or
- by programming the following decoder CVs individually, or the CVs are programmed automatically by the digital system (usually with American systems).

This chapter only covers the decoder-controlled consisting!

| CV  | Denomination  | Range  | Default | Description  |
|-----|---|--|---------|--|
| #19 | Consist address   | 0, 1 - 127<br>129 - 255<br>(= 1 - 127 with inverted direction) | 0       | Alternate loco address for consist function:<br>If CV #19 > 0: Speed and direction is governed by this consist address (not the individual address in CV #1 or #17&18); functions are controlled by either the consist address or individual address, see CVs #21 & #22.<br>Bit 7 = 1: Driving direction reversed  |
| #20 | Bits 0 - 6: Extended consist address<br>AND (independent of whether extended consist address is used)<br>Bit 7: Switching on RailCom response for consist address | 0 - 102,<br>128 - 130<br>Bit 7 SW version 4.225 and higher     | 0       | "Extended" consist address: the value defined in CV #20 is multiplied by 100 and added to the value in CV #19, which then results in the address in consist operation.<br>E.g. CV #20 = 12, CV #19 = 34 equals addr. 1234;<br>CV #20 = 100, CV #19 = 00 equals addr. 10000.<br>Bit 7 = 1: on RailCom address the Channel-2 messages (speed, direction information, etc.) are sent out, and in Channel-1 (on all addresses except own Consist) Consist address is reported.<br>The consist address is CV #19 (if CV #20 = 0); or CV #19 and #20 (see above, if CV #20 is not 0).  |
| #21 | Functions F1 - F8 in consist operation  | 0 - 255  | 0       | Functions so defined here will be controlled by the consist address.<br>Bit 0 = 0: F1 controlled by individual address<br>= 1: ..... by consist address<br>Bit 1 = 0: F2 controlled by individual address<br>= 1: ..... by consist address<br>..... F3, F4, F5, F6, F7<br>Bit 7 = 0: F8 controlled by individual address<br>= 1: ..... by consist address  |
| #22 | Functions F0 forw. rev. in consist function<br><br>and<br><br>Activating Auto-Consist   | 0 - 255  | 0       | Select whether the headlights are controlled by the consist address or individual address.<br>Bit 0 = 0: F0 (forw.) controlled by individual address<br>= 1: ..... by consist address<br>Bit 1 = 0: F0 (rev.) controlled by individual address<br>= 1: ..... by consist address<br>Bit 2 = 0: F9 (forw.) controlled by individual address<br>= 1: ..... by consist address<br>Bit 3 = 0: F10 (forw.) controlled by individual address<br>= 1: ..... by consist address<br>Bit 4 = 0: F11 (forw.) controlled by individual address<br>= 1: ..... by consist address<br>Bit 5 = 0: F12 (forw.) controlled by individual address<br>= 1: ..... by consist address |





| CV         | Denomination  | Range                        | Default | Description  |
|------------|---|------------------------------|---------|--|
|            |   |                              |         | Bit 7 = 1: F13 – F27 (all!) ...by consist address<br>Bit 6 = 1: <b>Auto-Consist</b> : The system changes automatically between individual and consist address, if one of the two addresses = speed 0 and the other =speed >0.                              |
| #97        | Change between individual address or consist per function key<br><b>SW version 4.210 and higher</b> | 0, 1 - 28                    | 0       | Using this key (only on the main address), you can switch between the main address of the decoder (on CV #1 or CVs #17, #18) or the consist address. But for this CV #21 and CV #22 must be set to CV value 0 and it replaces the command CV #22, Bit 6=1. |
| #151       | Reducing the motor regulation in consist op.<br><b>SW version 4.210 and higher</b>                  | Tens digit<br>1 - 9          | 0       | The tens digit reduces the motor compensation to 10 – 90 % according to the value in CV #58.   |
| #109, #110 | Automatic unilateral light suppression  | Bit 7 = 0, 1<br>Bit 7 = 0, 1 |         | If CV #109, bit 7=1 and CV #110, bit 7=1, the light suppression on the driver's cab side in consist operation is activated automatically.  |

All ZIMO decoders can operate on conventional layouts with DC power packs, including PWM throttles, in **analog DC** as well as in **analog AC** (Märklin transformers with high voltage pulse for direction

**ATTENTION:** DC analog will be implemented with SW version 4.50

change).

To allow analog operation,

**CV #29, bit 2 = 1 must be set. and CV #12, bits 0 and/or 4 = 1**

This is usually the case by default (CV #29 = 14, which includes bit 2 = 1 and CV #12 = 127), but analog operation may be turned off in many sound projects (sound decoders).

The actual behavior during analog operation, however, is strongly influenced by the locomotive controller (power pack). Especially when using a too weak transformer, the driving voltage can easily collapse when the decoder consumes current; which in particularly unfavorable cases leads to oscillation between operation and non-operation.

In analog operation, it is possible to adjust the acceleration momentum (CV #14, bit 6) and function outputs (CV #13 & #14) individually.

**NOTE:** Actual decoder settings may differ from the default values if a sound project is loaded.

| CV  | Denomination  | Range               | Default   | Description   |
|-----|---|---------------------|---|---|
| #12 | Possible operating modes<br>All bits of CV #12 are described in chapter "3.1 Basic Configuration"               |                     | 127   | Bit 0 - DC analog 0 = disabled <u>1</u> = enabled<br>Bit 4 - AC analog 0 = disabled <u>1</u> = enabled<br>Bit 5 ... (see chapter "3.1 Basic Configuration")   |
| #29 | Basic Configuration<br>all bits of CV #29 are described in chapter "3.1 Basic Configuration"                    | 0 - 63              | 14 =<br>0000 1110<br>therefore<br>Bit 2 = 1<br>(Analog operation) | Bit 1 ... (see chapter „3.1 Basic Configuration“)<br>Bit 2 - automatic change to analog operation<br>0 = disabled <u>1</u> = enabled<br>Bit 3 ...<br>Bit 4 ...<br>etc. ... (see chapter „3.1 Basic Configuration“)  |
| #13 | Functions<br>F1 - F8<br>Functions<br>F0 (forw. rev.)<br>F9 - F12<br>in analog operation<br>(= observation mode) | (CV #13)<br>0 - 255 | (CV #13)<br>0 (MN)<br>128 (MS)                                    | Bit 0 = 0: F1 is OFF in analog mode<br>= 1: ...ON in analog mode<br>Bit 1 = 0: F2 is OFF in analog mode<br>= 1: ... on<br>..... F3, F4, F5, F6, F7<br>Bit 7 = 0: F8 is OFF in analog mode<br>= 1: ... on  |
| #14 | and<br>Acceleration/<br>Deceleration, control<br>in analog operation  | (CV #14)<br>0 - 255 | (CV #14)<br>67<br>therefore<br>Bit 6 = 1:                         | Bit 0 = 0: F0 (forw) OFF in analog mode<br>= 1: ...ON in analog mode<br>Bit 1 = 0: F0 (rev) is OFF in analog mode<br>= 1: ...ON in analog mode<br>..... F9, F10, F11<br>Bit 5 = 0: F12 is OFF in analog mode<br>= 1: ...ON in analog mode<br>Bit 6 = 0: Analog operation with acceleration and deceleration according to CVs #3 and #4; useful for sound<br>=1: Analog operation <b>without</b> effect, i.e. without acceleration and deceleration according to CV #3 and #4.<br>Similar to a classical analog operation. |

### 3.5 Analog operation



### 3.6 Motor regulation and control

#### The speed curves

There are two types of speed curves; between those select with

CV #29, bit 4 = 0: 3-point speed curve (defined by 3 CVs)  
 ... = 1: 28-step curve (defined by 28 CVs)

**3-point speed curve:** the lowest, highest, and medium speed are defined by CVs #2 (Vstart), #5 (Vhigh) and #6 (Vmid) (=external speed step defined by slider position). This is a simple way to quickly establish a speed range and its curvature.

**28-point speed curve (a.k.a. "freely programmable speed curve"):** with the help of CVs #67 - #94, all 28 external speed steps can be assigned freely to the internal speed steps (0-255). These 28 CVs apply to all speed step modes (14, 28 and 128). If 128 external speed steps are used, the decoder adds the missing intermediate values by interpolation.

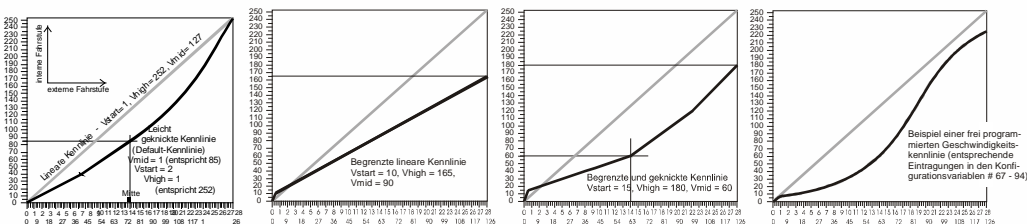

| CV  | Denomination  | Range                                | Default                  | Description  |
|-----|---|--------------------------------------|--------------------------|--|
| #2  | Start Voltage<br>Vstart<br>with 3-point table if<br>CV #29, bit 4 = 0 | 1 - 255                              | 1                        | Internal speed step (1 - 255) applied as <b>lowest</b> external speed step (= speed step 1) (applies to 14, 28, or 128 speed step modes) = <u>1</u> : lowest possible speed  |
| #5  | Top Speed<br>Vhigh<br>with 3-step curve if<br>CV #29, bit 4 = 0       | 0 - 255                              | 1<br>equals 255          | Internal speed step (1 - 255) applied as <b>highest</b> external speed step (i.e. for the external speed step 14, 28 or 128, depending on the speed step mode according to CV #29, bit 1 = 0) = 0: equals 255 as highest speed step = <u>1</u> : equals 255 as highest speed step  |
| #6  | Medium Speed<br>Vmid  | 1 - 1/4 to 1/2 of the Value in CV #5 | 1 (= @ 1/3 of top speed) | Internal speed step (1 - 255) for <b>medium</b> external speed step (i.e. for the external speed step 7, 14 or 64, depending on the speed step mode 14, 28 or 128 according to CV #29, bit 1) "1" = default characteristic (medium speed is set to one third of the top speed. I.e. if CV #5 = 255: the curve is the same as if CV #6 would be programmed to 85). The speed curve resulting from CVs #2, #5 and #6 is automatically smoothed out, therefore no sharp bends. The average speed is reached in the first third of the speed curve because it is not linear. |
| #29 | Basic configuration   | 0 - 63                               |                          | Bit 0 - Train direction:   |

| CV        | Denomination  | Range   | Default   | Description  |
|-----------|---|---------|---|--|
|           |   |         | 14 =<br>0000 1110<br>so bit 4 = 0<br>(3-point<br>Speed table) | 0 = normal, 1 = reversed<br>Bit 1 - Number of speed steps:<br>0 = 14, 1 = 28/128<br>Bit 2 - automatic change to analog operation<br>0 = disabled 1 = enabled<br>Bit 3 - RailCom („bidirectional communication“)<br>0 = deactivated 1 = activated<br>Bit 4 - Individual speed table:<br>0 = off, CVs #2, #5 and #6 are active.<br>1 = on, according to CVs #67 - #94<br>Bit 5 - Decoder address:<br>0 = primary address as per CV #1<br>1 = ext. address as per CVs #17 & #18 |
| #67 - #94 | Free (28-point) speed table<br>if CV #29, bit 4 = 1 | 0 - 255 | *)  | internal speed steps (each 1-255) for each of the 28 external steps.<br>*) The 28-point default curve is also bent, emphasising the lower speed range.   |
| #66 #95   | Directional speed trimming                          | 0 - 127 | 0<br>0  | Speed step multiplication by "n/128" (n is the trim value in this CV): #66: for forward direction; #95: for reverse direction  |

#### CV #57 - Voltage reference for the motor regulation

CV #57 specifies the reference value (voltage) used for motor regulation. For example: if 14 V is selected (CV value: 140) the decoder tries to send the exact fraction of this voltage determined by the position of the slider to the motor, regardless of the voltage level at the track. As a result, the speed remains constant even if the track voltage fluctuates, provided the track voltage (more precisely, the rectified and processed voltage inside the decoder, which is about 2 V lower) does not fall below the absolute reference voltage.

- The default value "0" in CV #57 selects the "relative reference", which automatically adjusts the reference voltage to the available track voltage. This setting is only useful, if the system can always keep the track voltage constant (stabilized track output) and the resistance along the track kept to a minimum. All ZIMO systems keep the track voltage stable - even older systems - but not every system from other manufacturers do, especially relatively cheap systems built before 2005. It is not recommended to set CV #57 to "0" with systems that do not keep track voltage stabilized. Instead set this CV to about 2 V below track voltage (i.e. 140 for 16 V).
- CV #57 can also be used as an alternative to CV #5 (top speed), which has the advantage that the full resolution of the 255 speed steps remains available.

| CV  | Denomination      | Range        | Default | Description  |
|-----|-------------------|--------------|---------|--|
| #57 | Voltage reference | 0, 100 - 255 | 0       | Absolute voltage in tenth of a volt applied to the motor at full speed (max. throttle setting). A useful (and well functioning) range is 10 to 24 V (i.e. 100-240), and lower than the expected track voltage.<br>EXAMPLE: A system from another manufacturer is set to 22 V at idle but drops to 16 V under load: A good setting would be CV #57 = 140 - 150.<br>CV #57 = 0: automatically adapts to the track voltage (relative reference); only useful with stabilized track voltage. |



*Tweaking the motor regulation by controlling algorithm*

The motor's performance, especially at crawling speeds (as judder-free as possible), can be fine-tuned with the following parameters:

**CV #9 – Motor control frequency and EMF sampling rate**

The motor's PWM is high frequency (typ. 20 kHz, also above the frequencies audible for the human ear). Compared to the low frequency control (used until the 1990s, usually around 100 Hz) **quiet** and **enginefriendly**.

**NOTE:** Frequencies higher than 20 kHz do not have an advantage for motor manufacturers and lead to a (slightly) higher heat loss within the decoder. Therefore, the option to 40 kHz on the new decoders is not planned anymore.

When using high frequency, the power supply to the motor is interrupted periodically with low frequencies (50 – 200 times/sec.), in order to determine the current speed by measuring back-EMF (voltage generated by the motor). The more frequent these interruptions happen (sampling rate), the better; but that also causes increased noise. By default, the sampling frequency varies automatically between 200 Hz at low speed and 50 Hz at maximum speed.

CV #9 allows the adjustment of the sampling rate (tens digits) as well as the sampling time (ones digits). The default value of 55 represents a medium setting.

**CV #56 or CVs #147, #148, #149 – The PID regulation**

The motor regulation can be tailored to motor type, vehicle weight and so on, by using different Proportional-Integral-Differential values. Changing the differential value can usually be omitted.

CV #56 allows the proportional value (tens digit) as well as the integral value (ones digit) to be set individually. The default value of 55 represents a medium setting. In MS-decoders, CV #56 exists solely for compatibility reasons; the fine adjustment is made possible by the new CVs #147, #148, #149:

CVs #147, #148, #149 automatically adapt to the modification of CV #56, NOT the other way round.

| CV | Denomination   | Range   | Default                                       | Description   |
|----|--|---|---|---|
| #9 | Motor control-period or frequency and EMF-sampling Rate (sampling rate, Sampling time)<br><br>Total PWM period | 0, 11 - 99<br><br>High frequency with modified sampling rate<br><br>100 – 199<br>From SW V. 4.215 | 55<br><br>High frequency medium Sampling rate | = 55: Default motor control with high frequency (20 kHz), medium EMF sampling rate that adjusts between 200Hz (low speed) and 50Hz and medium EMF sampling time.<br>= 0: equal to 0 (is converted automatically)<br><> 55 and <> 0: Modification of the default setting, each divided in: tens digit for sampling rate and ones digit (sampling time).<br>Hundreds digit 1: modified settings for coreless motors (Faulhaber, Maxxon, etc.)<br>Tens digit 1 - 4: Sampling rate lower than default (less noise)<br>Tens digit 6 - 9: Sampling rate higher than default (to combat juddering!)<br>Ones digit 1 - 4: EMF-sampling time shorter than by default (works well for Faulhaber, Maxxon, ... less noise, more power)<br>Ones digit 5 - 9: EMF-sampling time longer than default (may be needed for round motors or similar) |

|      |  |            |                                     |  |
|------|--|------------|-------------------------------------|--|
| #56  | P and I value for PID motor regulation (= EMK EMF-load balance control)<br><br>The value of this CV will be automatically transferred to CVs #147 - #149 | 0, 11 - 99 | 55<br>medium PID Setting            | = 55: Default motor control using medium values in PID parameters P and I (Diff = 0).<br>= 0: equal to 0 (is converted automatically)<br><> 55 and <> 0: modified settings<br><br>Tens digit 1 - 4: Proportional value of the PID-motor regulation, lower than default<br>Tens digit 6 - 9: Proportional value of the PID-motor regulation, higher than default<br>Ones digit 1 - 4: Integral value of the PID regulation lower than default<br>Ones digit 6 - 9: Integral value of the PID regulation higher than default<br><br>Typical test values against jerky driving:<br>CV #56 = 55 (default) → 33, 77, 73, 71, ...<br><b>ATTENTION:</b> The values 10, 20, 30, 40, 50, 60, 70, 80 and 90 are NOT allowed! |
| #147 | complete setting of PID parameters   | 0 - 255    | adapts to CV #56, if not programmed | Integral value of the PID-motor regulation, recommended for „modern“ powertrain: CV #147 = 65  |
| #148 | <b>NOTE:</b> are adjusted automatically with CV #56!   | 0 - 255    |                                     | Differential value of the PID-motor regulation, recommended for „modern“ powertrain: CV #148 = 45  |
| #149 |  | 0 - 255    |                                     | Proportional value of the PID-motor regulation, recommended for „modern“ powertrain: CV #149 = 65  |

*Tips on how to find the optimal CV #56 settings:*  
can also be used for #147, #148, #149:

Start with an initial setting of CV #56 = 11; set the engine at low speed while holding it back with one hand. The motor regulation should compensate for the higher load within half a second. If it takes longer than that, increase the ones digit gradually: CV #56 = 12, 13, 14, ...

Continue running at a low speed, increase the tens digit in CV #56. For example: (if the test above resulted in CV #56 = 13) start increasing the tens digit CV #56 = 23, 33, 43... as soon as driving conduct is detected, revert to the previous digit →this would be the final setting.

| CV   | Denomination  | Range   | Default | Description   |
|------|---|---------|---------|---|
| #112 | Special ZIMO Configuration data<br><br>SW version 5.00 and higher | 0 - 255 | 0       | Bit 2 = 0: ZIMO loco number recognition OFF<br>= 1: ZIMO loco number recognition ON |

**CV #58 - Load compensation**

**At this moment it is not clear, if this CV will also be necessary in MS-decoders.**

The goal of load compensation is to keep the speed at a constant level in all circumstances (only limited by available power). Though, a certain reduction in compensation is quite often preferred.

100 % load compensation is useful within the low-speed range to successfully prevent engine stalls or run-away under light load. Load compensation should be reduced as speed increases, so that at full speed the motor receives full power. Also, a slight grade-dependent speed change is often considered more prototypical.

Locomotives operated in consists should never run at 100 % load compensation in any part of the speed range, because it causes the locomotives to fight each other and could even lead to derailments.

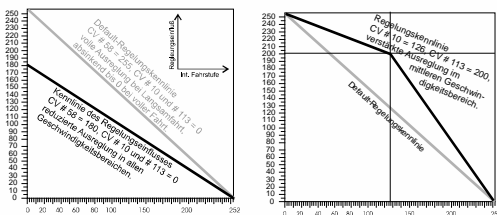

The overall intensity of load compensation can be defined with CV #58 from no compensation (value 0) to full compensation (value 255). Useful values range from 100 to 200.

For a more precise or complete load compensation throughout the full speed range use CV #10\* and CV #113 together with CV #58 to define a 3-point curve.

\* This applies to MX decoders. For MS decoders CV #10 is already used for another function. If CV #58 is implemented later, another CV number will be assigned here.

| CV  | Denomination                                     | Range   | Default | Description   |
|-----|--|---------|---------|---|
| #58 | BEMF intensity<br><br>SW version 5.00 and higher | 0 - 255 | 255     | Intensity of back-EMF control at the lowest speed step.<br><br>EXAMPLES:<br>CV #58 = 0: no back-EMF (like unregulated decoders),<br>CV #58 = 150: medium compensation,<br>CV #58 = 255: maximum compensation. |

### CV #151 - Motorbrake

This brake is useful for vehicles without worm gears to prevent them from rolling away or picking up speed on declines as well as to prevent a heavy train from pushing a standing engine downhill.

| CV   | Denomination   | Range  | Default | Description  |
|------|--|--------|---------|--|
| #151 | Reducing the motor regulation in consist operation.<br>(See description in chapter 0).<br><br>or<br><br>motor brake<br>(If address NOT in consist)<br><br>SW version 5.00 and higher | 0 - 99 | 0       | = 0: brake not active<br>= 1 - 9: In case of "zero power supply to the motor" (Motor PWM = 0) the speed to the desired speed step is still not reached (speed is still too high), the motor brake is slowly activated (distributed on 1, 2, ... 8 seconds until the full effect by short circuit on the motor through the power amplifier).<br><br>The higher the value, the faster and harder the brake is applied.<br><br>= tens digit (1-9): Reduction of the motor regulation if consist-key is active. The values 1-9 in the tens digits in CV #151 reduce the control to 10% - 90% of the value set in CV #58. |

### 3.7 Acceleration and deceleration momentum:

The basic acceleration and deceleration times (momentum) are set with CVs #3 and #4

according to the relevant NMRA standard, which demands a linear progression (the time between speed step changes remains constant over the whole speed range). For smooth drivability use values 3 or higher but for really slow starts and stops start with a value of 5; values higher than "30" are sel-

#### Important note regarding acceleration behavior - difference to ZIMO decoders of the MX-series:

The acceleration and deceleration behavior according to CVs #3 & #4 refers to the speed steps that are established by the speed table (including interpolation states), both with 3-point and 28-point speed table. This means, an exponential - not linear - speed table also triggers a corresponding acceleration and deceleration behavior. Usually (and by default) such a non-linear speed table is defined. MX-decoders adjust acceleration and deceleration in 255 equidistant speed steps, regardless of the speed table. Therefore, the MX-decoders have special CVs #121 and #122 to change the speed table to an exponential rate, which is not needed with the MS-decoders.

dom useful, except in combination with the "braking key".

The sound project in sound decoders always comes with different values in CVs #3 and #4 (as well as many other CVs) than what is listed in the CV table. Often the sound can only be played back correctly in combination with the acceleration times provided by the sound project (or certain minimum values). Therefore, the sound project's default values should not be changed too much.

| CV   | Denomination  | Range   | Default | Description   |
|------|---|---------|---------|---|
| #3   | Acceleration time   | 0 - 255 | (2)     | The value multiplied by 0.9 equals acceleration time in seconds from stop to full speed.<br>The effective default value for sound decoders is usually not the value given here, but is determined by the loaded sound project.  |
| #4   | Deceleration time   | 0 - 255 | (1)     | This CV, multiplied by 0.9, provides the time in sec for the deceleration from full speed to stop.<br>The actual default value: see above!  |
| #23  | Acceleration variation  | 0 - 255 | 0       | For a temporary elevation/decrease (Bit 7 = 0/1) of the acceleration time defined in CV #3.   |
| #24  | Deceleration variation  | 0 - 255 | 0       | For a temporary elevation/decrease (Bit 7 = 0/1) of the deceleration time defined in CV #4.   |
| #111 | Emergency delay time  | 0 - 255 | 0       | This CV value is valid for emergency stop instead of CV #4, i.e. for single stop and collective stop emerg.   |
| #123 | Adaptive Acceleration and deceleration momentum<br>SW version 5.00 and higher | 0 - 99  | 0       | Raising or lowering the speed to the next internal step occurs only if the preceding step is almost reached. The tolerance for reaching the preceding step can be defined by this CV (the smaller this value the smoother the acceleration/deceleration).<br>Value 0 = no adaptive accel. or decel.<br>Tens digit: 0 - 9 for acceleration (1 = strong effect)<br>Ones digit: 0 - 9 for deceleration<br>= 11: strongest effect |
| #394 | Bit 4: Faster Acceleration<br>Bit 4:  | 0 - 255 | -       | Bit 0 = 1: Light flashes at switchgear sound.<br>Bit 4 = 1: Faster acceleration and sound to high performance when slider is moved quickly to full speed  |



| CV   | Denomination  | Range     | Default | Description   |
|------|---|-----------|---------|---|
|      | SW version 5.00 and higher  |           |         | Bit 6 = 1: Impedes acceleration if brake key is active<br>Bit 7 = 1: Thyristor sound comes before departing   |
| #309 | Brake key   | 0, 1 - 29 | 0       | The key defined here acts as a brake key according to the rate defined in CV #349 (the normal – higher – deceleration time in CV #4 is thereby ignored). 0=deactivated; 1=F1, ..., 28=F28, 29=F0;   |
| #349 | Brake time for brake key  | 0 - 255   | 0       | To achieve the desired effect, the deceleration time in CV #4 must be set to a very high value (@ 50 - 250) but the brake time in CV #349 rather low (5 - 20). This simulates a coasting effect with the "regulator at 0", while the brake key results in a short stopping distance.  |
| #146 | Compensation for gear backlash during direction changes in order to reduce start-up jolt.<br><br>SW version 5.00 and higher   | 0 - 255   | 0       | = 0: no effect<br>=1 to 255: in case the driving direction was changed beforehand, the motor spins at minimum rpm for a defined timespan (according to CV #2) for a specific time and only starts to accelerate after this time has elapsed. The time of these "idle rotations" can only be tried; typical values:<br>= 100: the motor turns about 1 revolution or a maximum of 1 second at the minimum speed.<br>= 50: about ½ a turn or max. ½ second.<br>= 200: about 2 turns or max. 2 seconds.<br>Important: The minimum speed in CV #2 must be configured correctly, so that the train moves perfectly at the lowest speed step (1). Also, CV #146 is only useful if the load regulation is set to maximum or at least close to it (i.e. CV #58 = 200 – 255). |
| #347 | Key to switch key for driving and sound performance when driving solo   | 0 - 28    |         | = 0: no key, no solo drive<br>= 1 - 28: One function key (F1 – F28) acts as the switch-over key for driving a heavy train or a single locomotive.   |
| #348 | If the key for solo drive (CV #347, see above) is activated, the measures defined here have to be met.<br><br>Bit 2 already in version 4.10 bits 0, 3, 4 (only Diesel):<br>SW version 5.00 and higher | 0 - 31    |         | When driving solo (function key as per CV #347 is ON), ...<br>Bit 0 = 1: ... Diesel sound (sound steps) shall rise unlimitedly at acceleration (otherwise: limited by speed step, CV #389).<br>Bit 1 = 1: acceleration and deceleration times should be reduced according to CV #3 / #4, but consider: The reduction according to CV #390.<br>Bit 2 = 1: motor's idle sound should be played back when driving at low speeds, whereas the highest speed step shall still be playing the idle sound set in CV #391.<br>Bit 3 = 1: deactivate 2nd smoke fan and heating element with this key (diesel loco with two engines only drives with one).<br>Bit 4 = 1: Suppress brake squeal  |
| #390 | Momentum reduction when driving solo (engine only)  | 0 - 255   | 0       | When switching to solo driving with key defined in CV #347 the momentum reduction is activated (with CV #348, Bit 1):<br>CV #390 = 0 or 255: no reduction<br>= 128: Reduction to 50 %<br>= 64: Reduction to 25 %<br>= 1: virtually cancels it   |

**ATTENTION:** For HLU braking distances (ZIMO signal-controlled speed influence) see CV #49

### 3.8 Special Operating Mode "km/h speed regulation"

SW version 5.00 and higher



### 3.9 ZIMO “signal-controlled speed influence” (HLU)

ZIMO digital systems offer a second level of communication for transmitting data to vehicles on specific track sections. The most common application for this is the “signal-controlled speed influence” for stopping trains and applying speed limits in 5 stages, with data sent to the track sections as needed in the form of HLU cut-outs prepared by MX9 track section modules or its successors.

The speed limits “U” (Ultra-low) and “L” (Low speed) as well as the intermediate limits of the “signal-controlled speed influence” can be defined with configuration variables #51 to #55 as well as the acceleration and deceleration values (momentum) with CV #49 and #50.

Please note that the signal-controlled acceleration and deceleration times in CV #49 and #50 are always **added** to the times and curves programmed to CV #3, #4, #121, #122 etc. Signal controlled accelerations and decelerations compared to cab-controlled momentum can therefore only progress either at the same rate (if CVs #49 and #50 are not used) or slower (if CV #49 and/or #50 contain a value >0), but never faster.

It is of utmost importance for a flawlessly working train control system using the signal-controlled speed influence that the stop and related brake section lengths are arranged properly and consistently everywhere on the layout. Please consult the MX9 instruction manual.

The deceleration (often CV #52 for “U” limit) and braking (CV #4 and #50) characteristics should be set in a way, all locos come to a complete stop within about 2/3 of the stop section, which in HO is typically about 15 to 20 cm before the end of a stop section. Setting the loco up to stop precisely within the last centimeter of a stop section is not recommended.

For a correct HLU behaviour of MS and MN decoders in case of “old” ZIMO command stations (MX1EC, MX1 model 2000 or MX1HS) the CV #11 must be changed to 158 in the MX1(!) and the CV #27=1 must be set (also in MX1). These three MX1 command stations must also not have an (almost) empty 3 V button cell (recognizable by the fact that “data loss” is briefly shown on the MX1 display when the command station is started), because otherwise the changed value of CV #11 is not retained when the MX1 is switched off.

| CV  | Denomination                                  | Range   | Default | Description   |
|-----|---|---------|---------|---|
| #49 | Signal controlled (HLU, ABC) Acceleration     | 0 - 255 | 0       | ZIMO signal-controlled speed influence method (HLU) using MX9 or StEin:<br>or<br>with the “asymmetrical DCC signal” stopping method:<br>The value multiplied by 0.4 equals acceleration time in seconds from stop to full speed.<br>Only CV #3 <b>OR</b> CV #49 is used, depending on which value is higher.                        |
| #50 | Signal controlled (HLU, ABC) braking distance | 0 - 255 | 0       | ZIMO signal-controlled speed influence (HLU) with ZIMO MX9 track section module or StEin<br>or<br>when using the “asymmetrical DCC signal” stopping method:<br>The value multiplied by 0.4 equals deceleration time in seconds from full speed to stop.<br>Only CV #4 <b>OR</b> CV #50 is used, depending on which value is higher. |
| #51 | Signal controlled (HLU) speed limits          |         | 20      | ZIMO signal-controlled speed influence method (HLU) using MX9 or StEin:   |
| #52 | #52 for “U” (Ultra low)                       |         | 40 (U)  |   |
| #53 | #53 for “L” (Low speed)                       | 0 - 255 | 70      | Defines the internal speed steps for each of the 5 speed limits generated by HLU.   |
| #54 | #54 for “L” (Low speed)                       |         | 110 (L) |   |
| #55 | #51, #53, #55 intersteps                      |         | 180     |   |

### 3.10 Stop in front of a red signal and driving slowly by “asymmetrical DCC-Signal” stops (Lenz ABC)

The “asymmetrical DCC signal” is an alternative method for stopping trains (e.g. at a red signal). A simple circuit made up of 4 or 5 commercially available diodes is all that is required.

Usually, the stop section contains 3 to 5 silicon diodes in series and one diode in parallel in the opposite direction is the usual arrangement. The different voltage drops across the diodes results in an asymmetry of about 1 to 2 V. The direction in which the diodes are mounted determines the polarity of the asymmetry and with it the driving direction a signal stop is initiated.

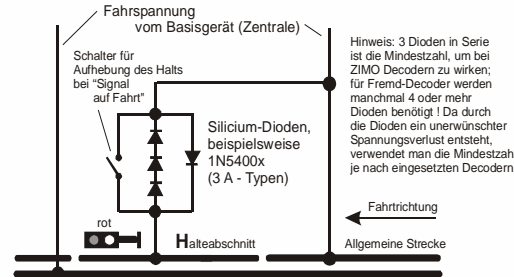

Usually, the stop section contains 3 to 5 silicon diodes in series and one diode in parallel in the opposite direction is the usual arrangement. The different voltage drops across the diodes results in an asymmetry of about 1 to 2 V. The direction in which the diodes are mounted determines the polarity of the asymmetry and with it the driving direction a signal stop is initiated.

The asymmetrical DCC signal stop mode needs to be activated in the decoder with CV #27. Usually, bit 0 is set, that is CV #27 = 1.

This results in the same directional control as the “Gold” decoder from Lenz.

| CV       | Denomination   | Range   | Default   | Description   |
|----------|--|---------|---|---|
| #27      | Position-dependent Stopping (“before a red signal”) or driving slowly by “asymmetrical DCC signal” (“Lenz ABC”) All details and settings are described in chapter “Stop in front of a red signal and driving slowly...“ or “ZIMO HLU” Automatic stopping by DC brake section, also: “Märklin brake section” Only possible, if analog operation is locked; i.e. if CV #12, bits 0 und 4 = 0 |         | 0 = ABC not active, HLU active, other brake sections not active | Bit 0 <u>and</u> Bit 1 = 0: ABC not activated; no stopping<br>Bit 0 = 1: Stops are initiated if the voltage in the right rail (in direction of travel) is higher than in the left rail. This (CV #27 = 1) is the usual ABC application)<br>Bit 1 = 1: ABC stops are initiated if the voltage in the left rail (in direction of travel) is higher than in the right rail. If bit 0 <u>or</u> bit 1 = 1 (only one of the two bits is set): Stopping is directional, i.e. only in direction of travel to the signal, travelling in opposite direction has no effect.<br>Bit 0 <u>and</u> Bit 1 = 1: Stops are independent of direction of travel. See chapter “3.10 Stop in front of a red signal and driving slowly by “asymmetrical DCC-Signal” stops (Lenz ABC)”<br>Bit 2 = 0: HLU train protection system (H, UH,...) active<br>= 1: Effect (halt, limit) of HLU deactivated<br>Bit 4 - DC braking section, if polarity is reversed<br>0 = disabled 1 = enabled<br>Bit 5 - DC braking section, if polarity is equal to direction of travel<br>0 = disabled 1 = enabled<br>Bit 4 <u>and</u> bit 5 = 1: stopping when DC voltage (e.g. by a diode) independent of the polarity (“Märklin brake section”) |
| #49, #50 | Acceleration, braking time   | 0 - 255 | 0   | Effect like HLU, therefore see chapter “3.9 ZIMO “signal-controlled speed influence” (HLU)”. If those CVs are not used, CVs #3 and #4 are valid.  |
| #53      | slow speed   | 0 - 255 | 70  | Internal speed steps for the ABC slow speed   |
| #100     | Current asymmetry voltage (from SW version 4.227)  | 0 - 255 |   | The CV #100 delivers when read out via PoM (=Prog On the Main, =OP Prog Mode) the asymmetry voltage measured AT THE TIME in tenths of a volt. For the read CV values of CV #100 the following applies:  |



| CV   | Denomination  | Range                   | Default | Description  |
|------|---|-------------------------|---------|--|
|      |   |                         |         | [...]<br>2 = 0.2 V Asymmetry right track higher voltage<br>1 = 0.1 V Asymmetry right track higher voltage<br>0 = perfectly symmetrical signal<br>255= 0.1 V Asymmetry left track higher voltage<br>254= 0.2 V Asymmetry left track higher voltage<br>[...]<br>The result is rounded to tenths of a volt, therefore the last bit may "flicker" a bit (e.g. with a measured rail voltage asymmetry of e.g. 1.44 V the CV sometimes returns 14 and sometimes 15 as CV value). |
| #101 | Correction factor for CV #100 (from SW version 4.227)       | 0 - 255                 | 0       | CV #101 can be used to define a correction factor in one of the two directions (only necessary for models with 6pol NEM 651 interface, where the consumers load one of the two rails).   |
| #134 | Asymmetry threshold for the "Asymmetric DCC - Signal" (ABC) | 1 - 14<br>= 0.1 - 1.4 V | 6       | <u>tens and ones digit</u> : asymmetry threshold in tenths of a volt. From this voltage difference between the half-waves of the DCC signal, the asymmetry is to be registered as such, and the stopping of the vehicle is initiated.<br>= 6 (default) therefore means 0.6 V asymmetry threshold. This normally seems to be an appropriate value; corresponding to the typical generation of the asymmetry by a circuit consisting of a total of 4 diodes.                 |
| #193 | ABC - commuting with stopping times in reverse loops        | 0,<br>1 - 255           | 0       | = 0: no commuting on ABC basis<br>= 1 - 255: Stopping period (in sec) in the ABC stopping (=turnaround) sections at the end of the commuting distance.   |
| #194 | ABC - commuting with additional stopovers                   | 0,<br>1 - 254,<br>255   | 0       | Only as commuting if CV #193 = 1 - 255<br>= 0: Commuting without stopovers (see above)<br>= 1 - 254: Commuting with stopovers (terminal loops by ABC slow-speed sections, stopovers defined by ABC stopping sections)<br>Stopping period (in sec) in the stopovers<br>= 255: as above but permanent stop in stopovers (until stop is cancelled).   |

### 3.11 DC Brake Sections, "Märklin brake mode"

| CV  | Denomination   | Range  | Default  | Description   |
|-----|--|--------|--|---|
| #29 | Basic Configuration  | 0 - 63 | 14 =<br>0000 1110<br>so<br>Bit 2 = 1                               | When using DC brake sections, the automatic switch-over to analog operation must be switched off.<br>So that settings in CV #27, bits 4 and 5 are effective:<br>CV #29, Bit 2 = 0<br>(e.g. CV #29 = 6, instead of the default value 14)<br>Bit 0 - Directional behavior<br>Bit 1 - Number of speed steps<br>Bit 2 - Automatic switching to analog operation<br>0 = off, 1 = switched on<br>Bit 3 - RailCom (bi-directional communication)<br>Bit 5 - Selection of vehicle address (DCC)   |
| #27 | Position-dependent Stopping ("before a red signal") or driving slowly by "asymmetrical DCC signal" ("Lenz ABC")<br>See chapter "3.10 Stop in front of a red signal and driving slowly by "asymmetrical DCC-Signal" stops (Lenz ABC)"<br>or<br>"ZIMO HLU" (see chapter "3.9 ZIMO "signal-controlled speed influence" (HLU)")<br>or<br>DC brake sections ("Märklin brake section") |        | 0 =<br>ABC not active, HLU active, other brake sections not active | Bit 0 <u>and</u> Bit 1 = 0: ABC not activated; no stopping<br>Bit 0 = 1: Stops are initiated if the voltage in the right rail (in direction of travel) is higher than in the left rail. This (CV #27 = 1) is the usual ABC application)<br>Bit 1 = 1: ABC stops are initiated if the voltage in the left rail (in direction of travel) is higher than in the right rail.<br>If bit 0 <u>or</u> bit 1 = 1 (only one of the two bits is set): Stopping is directional, i.e. only in direction of travel to the signal, travelling in opposite direction has no effect.<br>Bit 0 <u>and</u> Bit 1 = 1: Stops are independent of direction of travel. See chapter "3.10 Stop in front of a red signal and driving slowly by "asymmetrical DCC-Signal" stops (Lenz ABC)"<br>Bit 4 - DC braking section, if polarity is reversed<br>0 = disabled 1 = enabled<br>Bit 5 - DC braking section, if polarity is equal to direction of travel<br>0 = disabled 1 = enabled<br>Bit 4 <u>and</u> bit 5 = 1: stopping when DC voltage (e.g. by a diode) independent of the polarity ("Märklin brake section") |

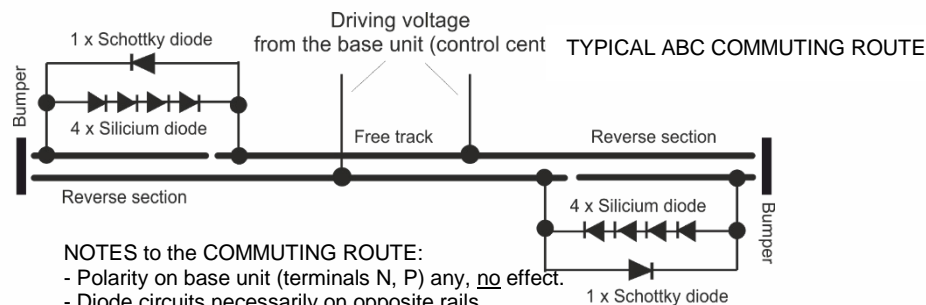

**NOTES to the COMMUTING ROUTE:**

- Polarity on base unit (terminals N, P) any, no effect.
- Diode circuits necessarily on opposite rails
- Configuration of the commuting decoder: CV #27 = 1, CV # 193 > 1



### 3.12 Distance controlled stopping - Constant Braking Distance

If the selection for constant braking distance has been made by CV #140 (= 1, 2, 3, 11, 12, 13), stopping (i.e. braking to a standstill) is performed according to this procedure, whereby the values set in

#### CV #141

is maintained as accurately as possible up to the stopping point, irrespective of the speed just travelled at the start of braking (the "entry speed").

The procedure is especially useful in connection with the automatic stop before a red signal (CV #140 = 1, 11) with the means of the ZIMO HLU ("signal-dependent train control") or the Lenz ABC (signal stop by "asymmetrical DCC signal"). CV #140 must be set to 1 or 11 for this.

Also activatable (by corresponding values in CV #140 = 2, 12), although of less practical importance, is the distance-controlled stop for manual driving, i.e. when the speed is set to 0 at the cab (controller).

| CV   | Denomination  | Range                        | Default | Description   |
|------|---|------------------------------|---------|---|
| #140 | Distance controlled stopping -<br>Constant Braking Distance<br>Selection of the braking occasion and the braking behavior | 0,<br>1, 2, 3, 11,<br>12, 13 | 0       | Activation of distance-controlled stopping (Constant Braking Distance) as defined in CV #141 instead of time-controlled braking as defined in CV #4, for = 1 automatic stop with ZIMO HLU ("signal-controlled speed influence") or ABC (signal stop by "asymmetric DCC signal").<br>= 2 manual stops by speed controller.<br>= 3 automatic <u>and</u> manual stopping.<br>In the above cases (= 1, 2, 3) braking from partial speeds is delayed so that the train does not "creep" for an unnecessarily long time (this is the recommended choice). On the other hand = 11, 12, 13 as above, but braking is always initiated as soon as the train is entering the stopping section. |
| #141 | Distance controlled stopping -<br>Constant Braking Distance<br>The braking distance                                       | 0 - 255                      | 0       | The value in this CV defines the "Constant Braking Distance". The value suitable for the existing braking distances must be determined by trial and error; as a guide can serve: CV #141 = 255 means approx. 500 m in the prototype (i.e. 6 m in H0), CV #141 = 50 is approx. 100 m (i.e. 1.2 m for H0).  |
| #830 | Braking distance forward High Byte  | 0 - 255                      | 0       | Extended definition of the Constant Braking Distance: With CV #830 - #833 a more precise and direction dependent braking distance can now be set. The factor compared to CV #141 is 1 to 16.  |
| #831 | Braking distance forward Low Byte   | 0 - 255                      | 0       |   |
| #832 | Braking distance backward High Byte   | 0 - 255                      | 0       |   |
| #833 | Braking distance backward Low Byte  | 0 - 255                      | 0       | The braking distance to be defined is calculated from: $(256 * \text{High Byte}) + \text{Low Byte}$ .<br>CVs #830 - #833 are only effective if CV #141 = 0.   |
| #143 | Distance controlled stopping -<br>Constant Braking Distance<br>Compensation for HLU method                                | 0 - 255                      | 0       | Since HLU is more error-resistant than ABC, no detection delay is usually necessary; therefore default 0.   |

The course of the "distance-controlled stopping" follows two possible procedures (see figures below): The first variant (CV #140 = 1, 2, 3) is recommended, where at lower entry speed the train initially continues unchanged for some time and then brakes "normally" (with the same deceleration as it would from full speed).

In the second variant (CV #140 = 11, 12, 13), on the other hand, the train starts braking immediately at the beginning of the stopping section even at low entry speed, which can lead to unnatural behaviour. However, for the purpose of adaptation to third-party products that operate similarly to the second variant, it may also be useful to select the latter.

Also, when using the "distance-controlled stop" in manual mode (CV #140 = 2 or 12) the second variant (i.e. CV #140 = 12) might be preferable so that the train reacts immediately to the controller.

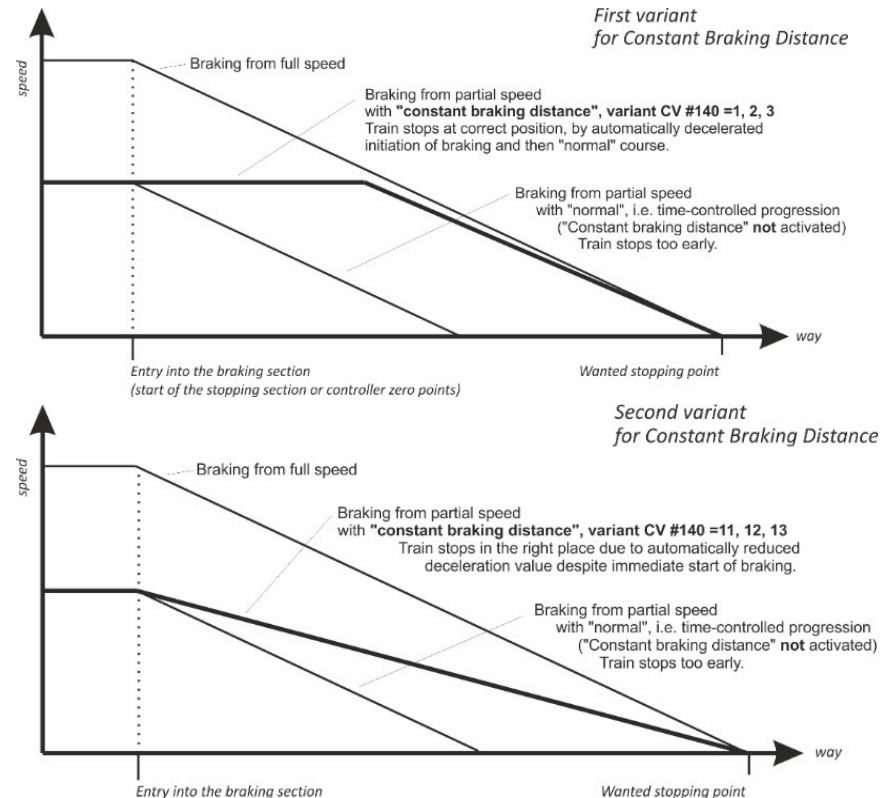





### 3.13 Shunting-, Half speed-, MAN-functions

On the one hand, defining the different Configuration Variables (#3, #4, #23, #24) offers prototypical acceleration and deceleration behavior, but is, on the other hand, often obstructive to quick and easy shunting.

Therefore, the momentum can temporarily be reduced or eliminated altogether with a dedicated function key. Also, during shunting maneuvers it is sometimes helpful to restrict the speed range of the speed controller to a partial range (half range).

| CV   | Denomination  | Range   | Default           | Description   |
|------|---|---|-------------------|---|
| #124 | <p>ATTENTION:<br/>bits 2, 3, 4, 6 (i.e. selection for shunt key functions) only apply when CVs #155 and #156 = 0 (these allow extended selection and are preferentially applied to new projects).<br/>Shunt key functions: Half speed, acceleration deactivation</p> <p>WHEREAS:<br/>Bits 0,1 (i.e. TYPE of acceleration deactivation) always apply, also together with CVs #155, #156.</p> <p>Bit 7:<br/>Switchover SUSI - Logic level outputs</p> | <p>Bits<br/>0 - 4, 6</p> <p>Bit 7</p>   | <p>0</p> <p>0</p> | <p>Selection of a shunt key for Activation of the HALF SPEED:<br/>Bit 4 = 1 (and bit 3 = 0): F3 as half-speed key<br/>Bit 3 = 1 (and bit 4 = 0): F7 as half-speed key<br/>Selection of a shunt key for deactivation of ACCELERATION TIMES:<br/>Bit 2 = 0 (and bit 6 = 0): MN key as accel. deact.<br/>Bit 2 = 1 (and bit 6 = 0): F4 as acceleration deactivation<br/>Bit 6 = 1 (bit 2 irrelevant): F3 as acceleration deact.<br/>TYPE (range of action) of the key (MN, F3 or F4) for Deactivation of acceleration times:<br/>Bits 1,0 = 00: no influence on acceleration times<br/>= 10: reduces acceleration/deceleration time to ¼ of the values according to CVs #3, #4.<br/>= 11: deactivates acceleration/deceleration time completely.<br/><u>EXAMPLES:</u><br/>F3 as half speed key, if CV #124 = 16<br/>F3 as half speed key and F4 to completely disable acceleration/deceleration time, if bits 0, 1, 2, 4 = 1, so CV #124 = 23<br/>F3 as half-speed key and for acceleration/deceleration deact. if bits 0, 1, 4, 6 = 1, i.e. CV #124 = 83</p> <p>Bit 7 = 0: SUSI-Schnittstelle aktiv (oder Servos, wenn in CVs #181, #182, ... definiert<br/>= 1: Logik-Pegel anstelle SUSI aktiviert.</p> |
| #155 | <p>to be preferred for new projects alternative to CV #124:</p> <p>Function key for half speed</p>  | <p>0,<br/>1 - 28,<br/>29,<br/>30</p> <p>and<br/>bits 7, 6, 5<br/>for<br/>setting<br/>Half-<br/>speed.</p> | <p>0</p>          | <p>In extension of the settings of CV #124, if the selection there (half speed on F3 or F7) is not sufficient, because another key is wanted:<br/>CV #155: Determination of the function key, with which the half speed (= highest speed step results in half speed) can be switched on.<br/>If CV #155 &gt; 0 (i.e. a key is set), a possible assignment in CV #124 is ineffective.<br/>If CV #155 =<br/>= 0: CV #155 is not active, so CV #124 is valid.<br/>= 1 - 28: Function key F1 - F28<br/>= 29: Function key F0<br/>= 30: MAN key<br/>Bits 7, 6, 5: Modification of the "half" speed".<br/>= 000: Speed according to speed step, multipl. by 0.625<br/>= 001 ... 100: ... speed step, multiplied by 0.125 ...0.5<br/>= 100 ... 111: ... speed step, multiplied by 0.5 ...0.875</p>   |
| #156 | to be preferred for new   | 0,  | 0                 | This CV overwrites the setting of the F keys in CV #124   |

|      |   |   |          |  |
|------|---|---|----------|--|
|      | <p>projects alternative to CV #124:</p> <p>Function key for the deactivation of Acceleration and deceleration times</p> | <p>1 - 28,<br/>29,<br/>30,</p> <p>129 - 156,<br/>157,<br/>158</p> |          | <p>(Bit 2&amp;6) in case it is not satisfactory. The set range (Bit 0&amp;1) of the acceleration behavior does not change.<br/>If CV #156 &gt; 0 (i.e. a key is set), any assignment in CV #124 is ineffective.<br/>If CV #155 =<br/>= 0 means CV #155 is not active, so CV #124 is valid.<br/>= 1 - 28: Function key F1 - F28<br/>= 29: Function key F0<br/>= 30: MAN key<br/>Bit 7 = 1: Suppression of switching the light when reversing direction.<br/>The settings of CV #124 about the type of deactivation or reduction still apply, thus:<br/>CV #124, bit 1, 0 =<br/>= 00: no influence on acceleration times<br/>= 10: reduces acceleration/deceleration time to ¼ of the values according to CVs #3, #4.<br/>= 11: deactivates acceleration/deceleration time completely.<br/>Typically, CV #124 = 3 is set to achieve full deactivation (unless other bits in CV #124 are also set).</p> |
| #157 | <p>Function key for the MAN-function</p> <p>Only for non-ZIMO controllers that don't have a dedicated MN key.</p>       | <p>0,<br/>1 - 28,<br/>29</p>                                      | <p>0</p> | <p>The MAN function (or MAN key on ZIMO controllers) was originally designed for ZIMO applications only, in order to cancel stop and speed limit commands applied by the "signal-controlled speed influence" system (HLU).<br/>This function was expanded in later software versions to include "asymmetrical DCC signal stops" (Lenz ABC).<br/>If ZIMO decoders are used with non-ZIMO systems which do not have this key (rarely with HLU, usually with ABC), a function key can now be assigned with CV #157 to cancel a signal-controlled speed limit or stop command.</p>   |



### 3.14 The NMRA-DCC function mapping

ZIMO small-scale decoders have between 4 and 12 function outputs (FO). Consumers connected to these outputs (lights, smoke generator etc.) are switched ON and OFF with the function keys on the controller. Which function key controls which function output can be defined with the NMRA function mapping.

#### CVs #33 to #46

define the NMRA function mapping. Unfortunately, this function mapping also has its limitations (only one 8-bit register is available for each function, which leaves only 8 outputs to select from) and only the headlight function is intended to change with direction.

| Function key on the controller | Numeric key on the ZIMO Controller | CV  | Function outputs |      |      |     |     | Function outputs |     |     |     |     | Rear light | Front light |     |     |   |   |
|--------------------------------|------------------------------------|-----|------------------|------|------|-----|-----|------------------|-----|-----|-----|-----|------------|-------------|-----|-----|---|---|
|                                |                                    |     | FO12             | FO11 | FO10 | FO9 | FO8 | FO7              | FO6 | FO5 | FO4 | FO3 |            |             | FO2 | FO1 |   |   |
| F0                             | 1 (L) fw                           | #33 |                  |      |      |     |     |                  | 7   | 6   | 5   | 4   | 3          | 2           | 1   | 0   |   | ● |
| F0                             | 1 (L) re                           | #34 |                  |      |      |     |     |                  | 7   | 6   | 5   | 4   | 3          | 2           | 1   | 0   | ● | 0 |
| F1                             | 2                                  | #35 |                  |      |      |     |     |                  | 7   | 6   | 5   | 4   | 3          | 2           | 1   | 0   | ● | 0 |
| F2                             | 3                                  | #36 |                  |      |      |     |     |                  | 7   | 6   | 5   | 4   | 3          | 2           | 1   | 0   | ● | 0 |
| F3                             | 4                                  | #37 |                  |      |      | 7   | 6   | 5                | 4   | 3   | 2   | 1   | 0          |             |     |     |   |   |
| F4                             | 5                                  | #38 |                  |      |      | 7   | 6   | 5                | 4   | 3   | 2   | 1   | 0          |             |     |     |   |   |
| F5                             | 6                                  | #39 |                  |      |      | 7   | 6   | 5                | 4   | 3   | 2   | 1   | 0          |             |     |     |   |   |
| F6                             | 7                                  | #40 |                  |      |      | 7   | 6   | 5                | 4   | 3   | 2   | 1   | 0          |             |     |     |   |   |
| F7                             | 8                                  | #41 | 7                | 6    | 5    | 4   | 3   | 2                | 1   | 0   |     |     |            |             |     |     |   |   |
| F8                             | 9                                  | #42 | 7                | 6    | 5    | 4   | 3   | 2                | 1   | 0   |     |     |            |             |     |     |   |   |
| F9                             | 0                                  | #43 | 7                | 6    | 5    | 4   | 3   | 2                | 1   | 0   |     |     |            |             |     |     |   |   |
| F10                            | ↑1                                 | #44 | 7                | 6    | 5    | 4   | 3   | 2                | 1   | 0   |     |     |            |             |     |     |   |   |
| F11                            | ↑2                                 | #45 | 7                | 6    | 5    | 4   | 3   | 2                | 1   | 0   |     |     |            |             |     |     |   |   |
| F12                            | ↑3                                 | #46 | 7                | 6    | 5    | 4   | 3   | 2                | 1   | 0   |     |     |            |             |     |     |   |   |

The black dots in the table above indicate the default settings at the time of delivery, where each function key corresponds to the same numbered function output. Therefore, the following values were written into these CVs by default:

- CV #33 = 1
- CV #34 = 2
- CV #35 = 4
- CV #36 = 8
- CV #37 = 2
- CV #38 = 4
- CV #39 = 8
- CV #40 = 16
- CV #41 = 4
- and so on..

EXAMPLE of a modification to the function mapping: The F2 key (ZIMO #3 key) should switch output FO4 in addition to output FO2. Moreover, F3 and F4 should NOT switch FO3 and FO4 but rather FO7 and FO8 (couplers, for example). New values are to be entered into the relevant configuration variables as follows:

CV #36=40  
CV #37 = 32  
CV #38 = 64

|    |   |     |  |  |  |  |  |  |   |   |   |   |   |   |   |   |
|----|---|-----|--|--|--|--|--|--|---|---|---|---|---|---|---|---|
| F2 | 3 | #36 |  |  |  |  |  |  | 7 | 6 | 5 | 4 | 3 | 2 | 1 | 0 |
| F3 | 4 | #37 |  |  |  |  |  |  | 7 | 6 | 5 | 4 | 3 | 2 | 1 | 0 |
| F4 | 5 | #38 |  |  |  |  |  |  | 7 | 6 | 5 | 4 | 3 | 2 | 1 | 0 |

### 3.15 Function mapping "without left shift"

By

CV #61 = 97

the left shift of higher CVs (#37 and up, according to the original NMRA function mapping) is deactivated, which allows higher function keys to be mapped with lower function outputs: e.g.: "F4 controls FO1" is not possible with NMRA, but is with ZIMO.

FO6 FO5 FO4 FO3 FO2 FO1 Headlights rear front

|     |            |     |   |   |   |   |   |   |   |   |   |   |   |   |   |   |   |   |
|-----|------------|-----|---|---|---|---|---|---|---|---|---|---|---|---|---|---|---|---|
| F0  | 1 (L) for. | #33 |   |   |   |   |   |   | 7 | 6 | 5 | 4 | 3 | 2 | 1 | 0 |   | ● |
| F0  | 1 (L) rev  | #34 |   |   |   |   |   |   | 7 | 6 | 5 | 4 | 3 | 2 | 1 | 0 | ● | 0 |
| F1  | 2          | #35 |   |   |   |   |   |   | 7 | 6 | 5 | 4 | 3 | 2 | 1 | 0 | ● | 0 |
| F2  | 3          | #36 |   |   |   |   |   |   | 7 | 6 | 5 | 4 | 3 | 2 | 1 | 0 | ● | 0 |
| F3  | 4          | #37 |   |   |   | 7 | 6 | 5 | 4 | 3 | 2 | 1 | 0 |   |   |   |   |   |
| F4  | 5          | #38 |   |   |   | 7 | 6 | 5 | 4 | 3 | 2 | 1 | 0 |   |   |   |   |   |
| F5  | 6          | #39 |   |   |   | 7 | 6 | 5 | 4 | 3 | 2 | 1 | 0 |   |   |   |   |   |
| F6  | 7          | #40 |   |   |   | 7 | 6 | 5 | 4 | 3 | 2 | 1 | 0 |   |   |   |   |   |
| F7  | 8          | #41 | 7 | 6 | 5 | 4 | 3 | 2 | 1 | 0 |   |   |   |   |   |   |   |   |
| F8  | 9          | #42 | 7 | 6 | 5 | 4 | 3 | 2 | 1 | 0 |   |   |   |   |   |   |   |   |
| F9  | 0          | #43 | 7 | 6 | 5 | 4 | 3 | 2 | 1 | 0 |   |   |   |   |   |   |   |   |
| F10 | ↑1         | #44 | 7 | 6 | 5 | 4 | 3 | 2 | 1 | 0 |   |   |   |   |   |   |   |   |
| F11 | ↑2         | #45 | 7 | 6 | 5 | 4 | 3 | 2 | 1 | 0 |   |   |   |   |   |   |   |   |
| F12 | ↑3         | #46 | 7 | 6 | 5 | 4 | 3 | 2 | 1 | 0 |   |   |   |   |   |   |   |   |



### 3.16 “Unilateral light suppression”

| CV   | Denomination   | Range   | Default | Description  |
|------|--|---------|---------|--|
| #107 | Turn off lights (i.e. front headlights AND additionally defined function output) at Driver's cab 1 (front) ..... | 0 - 220 | 0       | The value of this CV is calculated as follows:<br>Number of a function output (FO1 - FO6) x 32 + number of a function key (F1, F2, ...F28) → ... value of CV #107.<br>Function key: The key (F1 - F28) with which ALL lights on the cab's side are turned off, i.e. output "front light" AND<br>Function outputs: e.g. rear lights on this side. |
| #108 | Driver's cab 2 (back)  | 0 - 255 | 0       | As CV #107, but for other side of the loco.  |
| #109 | Add. Fu-output 1 side  | 1 - 6   | 0       | Function output is turned off with CV #107.  |
| #110 | Add. Fu-output Page 2  | 1 - 6   | 0       | Function output is turned off together with CV #108.   |

**Tip: Direction dependent taillights with special effect CVs:**

With the NMRA function mapping it is only possible to have function F0 directional because it was intended for the headlights, so they automatically switch between “front” and “rear” when changing direction. All Functions F1 - F12 are controlled independent of the direction of travel.

The special effect CVs #125 - #132, #159 and #160 (see chapter “3.21 Effects for function outputs (US and other lighting effects, smoke generators, uncouplers, etc.) ...”), are each assigned to one function output (up to FO8), and enable having more direction dependent functions. Therefore, only the direction-bits within the effect CVs are used, the actual effect bits are configured to 0.

**EXAMPLE 1:** Two red taillights are connected to function outputs FO1 and FO2 (front and rear). Both are to be actuated with F1 but should also change with direction. Therefore,

CV #35 = 12 (for F1, bit 2 for FO1 and bit 3 for FO2), additionally, the Effect CVs CV #127 = 1 (for FO1) and CV #128 = 2 (for FO2).

This way, FO1 is only activated when driving forward, FO2 only when driving backwards (only if F1 is activated).

**EXAMPLE 2:** Contrary to example 1 where the red taillights were switched independent of the white ones depending on the direction, in this example the headlights and taillights (read AND white) are switched ON/OFF together at the proper end of the locomotive with F0 or F1 (depending on which end the loco is coupled to the train) - “unilateral light suppression”.

This can be done as follows:

Connect: White front headlights connected to function output “front headlights” /  
Red front headlights to function output FO2 /  
White rear headlights to function output FO1 /  
Red rear taillights to function output “rear headlights” (!).

CV #33 = 1 and CV #34 = 8 front white headlights on F0forw and front red taillights on F0rev!  
CV #35 = 6 (both white headlights as well as red taillights in the rear on F1!)

CV #126 = 1 / CV #127 = 2

(Direction dependence for rear white and red lights by means of “Special Effects” CVs).

### 3.17 The “Swiss Mapping”

The “Swiss mapping” is a function mapping that allows the **loco lighting** to be used as is required by Swiss locomotives, which is of course also useful for locos of other countries.

The purpose of the "Swiss mapping" is to switch the various states of the locomotive lighting (turning on and dimming individually) with different function keys, i.e. for situations like driving a single locomotive, cars coupled on driver's cab 1, or at the driver's cab 2, push-pull, shunting, etc.

Using this relatively complex method is, of course, only worthwhile if the vehicle is equipped with many independently connected lights (or LEDs) and the decoder offers as many function outputs, this should be at least 6. ZIMO decoders (except for few miniature decoders) offer indeed between 6 and 10 function outputs, large-scale decoders even more.

The desired lighting states are defined by a **total of 17 CV groups, each group containing 6 CVs**. (i.e. 102 CVs; CV #430 - #507 + #800 - #823). The principle is simple, in that the first CV of each group contains the number (1 to 28) for a function key F1 - F28, and the other CVs define which function outputs are to be switched with this key, each dependent on the direction of travel.

| CV   | Denomination   | Range   | Default | Description   |
|------|--|---|---------|---|
| #430 | Swiss Mapping Group 1<br>“F-key”   | 0 - 28,<br>29 (for F0)<br>129 - 157                                     | 0       | With the F-key defined here, the function outputs defined in A1 (Forw or Rev) and A2 (Forw or Rev) shall be turned on.<br>Bit 7 = 1: Inverts the F-key function.  |
| #431 | Swiss Mapping Group 1<br>“M-key”<br>or<br>Special setting<br>“full beam” | Bit 0 - 6:<br>0 - 28,<br>29 (for F0)<br>and Bit 7<br>or<br>255          | 0       | The “normal function mapping” of the M-key defined here shall be deactivated (i.e. the corresponding outputs like headlights are turned off), if the F-key is turned on.<br>Bit 7 = 1: additionally, the outputs listed under A1 and A2 should only switch ON if F and M key are ON.<br>Bit 6 = 1: The M-key outputs shall not be turned OFF if the F-key is ON and driving forward.<br>Bit 5 = 1: The M-key outputs shall not be turned OFF if the F-key is ON and driving backwards.<br>= 157: is an often-used value for CV #431, because F0 (=29) is usually defined as M-key with bit 7 = 1. F0 then acts as a general ON/OFF key.<br>= 255 (Special <b>high-beam</b> setting!): the FOs defined in the following four CVs are switched to full intensity, if they are controlled via the "normal function mapping", and dimmed with CV #60; this function is used, for example, to switch the headlights of a Swiss locomotive to high-beam, without switching the white taillight to high-beam.<br>Depending on CV #399: High beam is only switched on if the speed is higher than the value given in this CV (255 step mode). |
| #432 | Swiss Mapping Group 1<br>“A1” forward                                    | Bits 0 - 3:<br>1 - 12<br>14 (FO0f)<br>15 (FO0r)<br>Bits 5 - 7:<br>0 - 7 | 0       | Bits 0 - 3:<br>Function output to be switched ON in forward direction provided that <b>both</b> the “F” and “M”-keys are ON (if bit #7 for the M-key = 1, otherwise F-key ON is sufficient).<br>Bits 7, 6, 5 (7 possible values or zero):<br>Number of the applicable dimming CV. For example: Bit 5 = 1 means dimming according to CV #508 etc.  |
| #433 | Swiss Mapping Group 1  | Bits 0 - 3:   | 0       | Bits 0 - 3:   |



|                |                                       |   |   |  |
|----------------|---------------------------------------|---|---|--|
|                | "A2" forward                          | 1 - 12<br>14 (FO0f)<br>15 (FO0r)<br>Bits 5 - 7:<br>0 - 7                |   | Additional function output to be switched ON in forward direction provided that <u>both</u> the "F" and "M"-keys are ON (if bit #7 for the M-key = 1, otherwise F-key ON is sufficient).<br>Bits 7, 6, 5 (7 possible values or zero):<br>Number of the applicable dimming CV. For example:<br>Bit 5 = 1 means dimming according to CV #508 etc.                |
| #434           | Swiss Mapping Group 1<br>"A1" reverse | Bits 0 - 3:<br>1 - 12<br>14 (FO0f)<br>15 (FO0r)<br>Bits 5 - 7:<br>0 - 7 | 0 | Bits 0 - 3:<br>Function output to be switched ON in reverse direction provided that <u>both</u> , the "F" and "M"-keys are ON (if bit #7 for the M-key = 1, otherwise F-key ON is sufficient).<br>Bits 7, 6, 5 (7 possible values or zero):<br>Number of the applicable dimming CV. For example:<br>Bit 5 = 1 means dimming according to CV #508 etc.          |
| #435           | Swiss Mapping Group 1<br>"A2" reverse | Bits 0 - 3:<br>1 - 12<br>14 (FO0f)<br>15 (FO0r)<br>Bits 5 - 7:<br>0 - 7 | 0 | Bits 0 - 3:<br>Additional function output to be switched ON in reverse direction provided that <u>both</u> the "F" and "M"-keys are ON (if bit #7 for the M-key = 1, otherwise F-key ON is sufficient).<br>Bits 7, 6, 5 (7 possible values or zero):<br>Number of the applicable dimming CV. For example:<br>Bit 5 = 1 means dimming according to CV #508 etc. |
| #436<br>- #441 | ... Group 2.                          | ...   | 0 | All 6 CVs in group 2 are defined the same way as the 6 CVs in group 1.   |
| #442<br>- 447  | ... Group 3.                          | ...   | 0 | All 6 CVs of the following groups are defined the same way is the 6 CVs in group 1.  |
| #448<br>- #453 | ... Group 4.                          | ...   | 0 | ...  |
| #454<br>- #459 | ... Group 5.                          | ...   | 0 | ...  |
| #460<br>- #465 | ... Group 6.                          | ...   | 0 | ...  |
| #466<br>- #471 | ... Group 7.                          | ...   | 0 | ...  |
| #472<br>- #477 | ... Group 8.                          | ...   | 0 | ...  |
| #478<br>- #483 | ... Group 9.                          | ...   | 0 | ...  |
| #484<br>- #489 | ... Group 10.                         | ...   | 0 | ...  |
| #490<br>- #495 | ... Group 11.                         | ...   | 0 | ...  |
| #496<br>- #501 | ... Group 12.                         | ...   | 0 | ...  |
| #502<br>- #507 | ... Group 13.                         | ...   | 0 | ...  |
| #800<br>- #805 | ... Group 14.                         | ...   | 0 | ..   |
| #806<br>- #811 | ... Group 15.                         | ...   | 0 | ...  |
| #812           | ... Group 16.                         | ...   | 0 | ...  |

|                                      |   |   |     |  |
|--------------------------------------|---|---|-----|--|
| - #817                               |   |   |     |  |
| #818<br>- #823                       | ... Group 17.   | ...   | 0   | ...  |
| #508<br>#509<br>#510<br>#511<br>#512 | Dimming values for the<br>"Swiss Mapping"<br><br>Special configurations | (0- 31)*8<br>(Only bits<br>3 - 7 are<br>used)<br><br>Bits 0 - 2 | 248 | Each group-CV (i.e. #432, #433, #434, #435) can be linked to one of these five dimming CVs.<br>This means that the function outputs shall be dimmed accordingly when switched on.<br>Value 0 = dark, value 31 = not dimmed.<br>Usable only with function outputs FO0 to FO13.<br><br>Bit 0 = 1: suppresses the lighting effect<br>Bit 1 = 1: Flashing effect<br>Bit 2 = 1: Inverted flashing   |
| #399                                 | Speed<br>dependent high beam<br>(Rule 17)<br><br>From SW version 5.00   | 0 - 255   | 0   | In combination with the "Swiss Mapping" special high-beam setting, see CV #431 = 255; applies to all 17 CV-groups (CV #437, #443, ...):<br>Switches to high-beam only when the speed exceeds the value in this CV; based on the decoder's internal 255 speed steps.<br><u>EXAMPLES and SPECIAL CASES:</u><br>= 0: High-beam at any speed (incl. stand-still), controlled only by the F-key (e.g. as per CV #430).<br>= 1: High-beam only while driving (not at stand-still), otherwise controlled by the F-key (e.g. CV #430).<br>= 128: Switches to high-beam when reaching medium speed. |



|       | vorne | hinten |
|-------|-------|--------|
| Lvor  | ● ○   | ○ ○    |
| Lrück | ○ ○   | ○ ●    |
| FA1   | ○ ○   | ○ ○    |
| FA2   | ○ ○   | ○ ○    |
| FA3   | ○ ○   | ○ ○    |
| FA4   | ○ ○   | ○ ○    |
| FA5   | ○ ○   | ○ ○    |
| FA5   | ○ ○   | ○ ○    |

The application of the "Swiss Mapping" is shown here with the example of an SBB Re422 engine.

◀ Lights or groups of lights are shown here as they exist in a typical SBB (Swiss) electric locomotive. Task of the Swiss mapping here is to show all possible operating states concerning the lighting (in both directions) correctly, using:

F0 (general ON/OFF), and  
F15, F16, F17, F18, F19, F20.

This results in a table, as you can see on the right▶  
The "Swiss Mapping" is configured as follows:

|           |            |           |          |           |          |
|-----------|------------|-----------|----------|-----------|----------|
| #33 = 133 | #34 = 42   |           |          |           |          |
| #430 = 15 | #431 = 157 | #432 = 14 | #433 = 1 | #434 = 15 | #435 = 1 |
| #436 = 15 | #437 = 157 | #438 = 2  | #439 = 0 | #440 = 2  | #441 = 0 |
| #442 = 16 | #443 = 157 | #444 = 14 | #445 = 1 | #446 = 3  | #447 = 4 |
| #448 = 17 | #449 = 157 | #450 = 5  | #451 = 6 | #452 = 15 | #453 = 2 |
| #454 = 18 | #455 = 157 | #456 = 6  | #457 = 0 | #458 = 4  | #459 = 0 |
| #460 = 19 | #461 = 157 | #462 = 2  | #463 = 0 | #464 = 1  | #465 = 0 |
| #466 = 20 | #467 = 157 | #468 = 0  | #469 = 0 | #470 = 0  | #471 = 0 |

Explanation:

The normal NMRA function mapping in CV #33 and CV #34 (front and rear headlight) determines the lighting in case F0 is ON and function keys F15 – F20 are OFF: CV #33 = 133 (= Lfor, FO1, FO6) and CV #34 = 42 (= Lrev, FO2, FO4).

The following CVs groups (1. Group: CV #430 – 435, CV #436 – 441 etc.), each group shown on one line, contain in the first CV the number of the "F-key" F15, F16, F17, F18, F19, F20, followed by the CVs for the "M-key" and function outputs to be switched.

Note that there are two groups for F15 (CV #430... and #436...) because F15 should switch 3 function outputs simultaneously, but only 2 can be entered per group (A1, A2 for each direction); for all other "F-keys" one group is enough.

All "M-Keys" (the second CV in each group) are all set to "157"; this means that "F0" and the condition of Bit 7 must be met, which means that the selected outputs are only activated if the F- and M-keys are ON.

The third to sixth CVs in each group contain the numbers of the function outputs to be actuated (where the headlights are coded with "14" and "15", for all other outputs just use the digit in FO1, FO2...).

| Funktionen, Tasten                      | Ausgänge            |   | vorne | hinten |
|---|---------------------|---|-------|--------|
| F0, vorwärts (Führerstand 1 voran)      | Lvor<br>FA1<br>FA6  | Alleinfahrt   | ● ●   | ○ ●    |
| F0, rückwärts (Führerstand 2 voran)     | Lrück<br>FA2<br>FA4 | Alleinfahrt   | ○ ●   | ○ ●    |
| F0 + F15, vorwärts (Führerst. 1 voran)  | Lvor<br>FA1<br>FA2  | Zugfahrt, Wagen gekuppelt auf Seite des Führerstands 2, Standardzug ohne Steuerwagen              | ● ●   | ○ ●    |
| F0 + F15, rückwärts (Führerst. 2 voran) | Lrück<br>FA1<br>FA2 | Zugfahrt, Wagen gekuppelt auf Seite des Führerstands 1, Standardzug ohne Steuerwagen              | ○ ●   | ○ ●    |
| F0 + F16, vorwärts (Führerst. 1 voran)  | Lvor<br>FA1         | Zugfahrt, Wagen an Führerst. 2, Zug mit Steuerwagen oder erste Lok in Doppeltraktion              | ● ●   | ○ ○    |
| F0 + F16, rückwärts (Führerst. 2 voran) | FA3<br>FA4          | Schiebe-Fahrt, Wagen Führerst. 2 Zug mit Steuerwagen (seit dem Jahr 2000)                         | ○ ○   | ○ ○    |
| F0 + F17, rückwärts (Führerst. 1 voran) | Lrück<br>FA2        | Zugfahrt, Wagen an Führerst. 1, Zug mit Steuerwagen oder erste Lok in Doppeltraktion              | ○ ○   | ○ ●    |
| F0 + F17, vorwärts (Führerst. 2 voran)  | FA5<br>FA6          | Schiebe-Fahrt, Wagen Führerst. 1 Zug mit Steuerwagen (seit dem Jahr 2000)                         | ○ ○   | ○ ●    |
| F0 + F18, vorwärts (Führerst. 1 voran)  | FA6                 | Schiebe-Fahrt, Wagen Führerst. 1 Zug mit Steuerwagen oder letzte Lok in Doppeltraktion (bis 2000) | ○ ○   | ○ ●    |
| F0 + F18, rückwärts (Führerst. 2 voran) | FA4                 | Schiebe-Fahrt, Wagen Führerst. 2 Zug mit Steuerwagen oder letzte Lok in Doppeltraktion (bis 2000) | ○ ●   | ○ ○    |
| F0 + F19, vorwärts (Führerst. 1 voran)  | FA2                 | Zugfahrt als letzte Traktions-Lok, Wagen an Führerstand 2   | ○ ○   | ○ ●    |
| F0 + F19, rückwärts (Führerst. 2 voran) | FA1                 | Zugfahrt als letzte Traktions-Lok, Wagen an Führerstand 1   | ○ ●   | ○ ○    |
| F0 + F20, vor-/ rückwärts               | ---                 | Mittlere Lok in Mehrfachtraktion  | ○ ○   | ○ ○    |



### 3.18 ZIMO “Input Mapping” SW version 3.00 and higher

The NMRA function mapping limitations (only one of 8 functions per one of the 12 function keys) can be overcome with the ZIMO “input mapping”. Additionally, the function keys (= **external functions**) can quickly be adapted to the wishes of the operator and that for both, function outputs and sound functions, without the need of changing the **internally mapped functions** and especially without changes to the sound projects:

CVs #400 - #428

| CV          | Denomination  | Range                                    | Default | Description  |
|-------------|---|--|---------|--|
| #400        | Input mapping for internal F0<br><br>that is, which function key switches the internal (decoder) function F0. | 0,<br>1 - 28, 29<br>30 - 187<br>254, 255 | 0       | = 0: Key F0 (i.e. F0 from the DCC packet) is sent to the internal F0 (1:1).<br>= 1: Key F1 is sent to the internal F0.<br>.....<br>= 28: Key F28 is sent to the internal F0.<br>= 29: Key F0 is sent to the internal F0.<br>= 30: = 30: Key F1 to F0, only in forward direction<br>.....<br>= 57: Key F28 to F0, only in forward direction<br>= 58: Key F0 to F0, only in forward direction<br>= 59: Key F1 to F0, only in reverse direction<br>.....<br>= 86: Key F28 to F0, only in reverse direction.<br>= 87: Key F0 to F0, only in reverse direction.<br>= 101: Key F1-inverted to internal F0.....<br>.....<br>= 187: Key F1-inverted to internal F0, only in reverse direction<br>= 254: Direction bit to internal F0, in forward dir.<br>= 255: Directions Bit to internal F0, in reverse dir. |
| #401 - #428 | Input mapping for internal F1 - F28   | 0,<br>1 - 28, 29,<br>30 - 255            | 0       | Same as input mapping above for other functions:<br>CV #403 = 1: Key F1 is forwarded to F3<br>= 9: Key F9 is forwarded to F3, etc.   |

### 3.19 Dimming, High/Low beam and Direction Bits

Some things connected to function outputs may sometimes require less than full track voltage, as is the case for example with 18 V bulbs when having 24 V on the track (quite common on large scale model railroads). Other times you simply want to reduce the brightness of the headlights.

The best solution in such cases is to connect the positive side of such devices to the low voltage supply of the decoder (see chapter “7 Installation and connection of the ZIMO decoder”). These outputs are fully stabilized so the voltage does not fluctuate with changes in track voltage.

Alternatively, or additionally (the dimming does not only work if the load is connected to the positive pole with full rail voltage, but also relative to a function low voltage) the voltage reduction via PWM dimming (pulse width modulation) is available with

CV #60

which defines the PWM duty cycle. Of course, this kind of voltage reduction is interesting because it is easy to change at any time by changing the value in CV #60.

**ATTENTION:** Bulbs with voltage ratings as low as 12 V can be dimmed with this PWM dimming function without damage even if track voltages are considerably higher; but **not** bulbs rated below that such as 5 V or 1.2 V bulbs. Those must be connected to one of the decoder’s low voltage supply pins instead of a “normal” positive pin.

LEDs, on the other hand, always require a series resistor; if, however, a resistor is selected that lowers the voltage to 5 V, the PWM dimming can also be used even at a track voltage of 25 V (in this case the setting would be CV #60 = 50, so a reduction to one fifth).

Generally, CV #60 applies to all function outputs. Specific outputs can be excluded from the dimming function, using the dimming mask CVs (see table).

| CV   | Denomination   | Range  | Default    | Description  |
|------|--|--|------------|--|
| #60  | Dimming the function outputs =<br><br>voltage reduction of the function outputs by PWM<br><br>Generally, this affects all function outputs.  | 0 - 255                                      | 0          | Reduction of function output voltage with PWM (pulse width modulation), to reduce the light’s brightness, for example.<br><br><u>EXAMPLES:</u><br>CV #60 = 0 or 255: full voltage<br>CV #60 = 170: 2/3 of full voltage<br>CV #60 = 204: 80 percent of full voltage   |
| #114 | Dim Mask 1 =<br><br>Excludes specific function outputs from dimming as per CV #60<br><br>Also see Addition to CV #152                        | Bits 0 - 7                                   | 0          | Enter function outputs that are <b>not</b> to be dimmed by CV #60. These outputs will receive the full voltage from the pin they are connected to. That is, either full track voltage or low voltage from a low-voltage pin.<br>Bit 0 - front headlights<br>Bit 1 - rear headlights<br>Bit 2 - function output FO1, Bit 3 - FO2,<br>Bit 4 - function output FO3, Bit 5 - FO4,<br>Bit 6 - function output FO5, Bit 7 - FO6,<br>Respective Bit = 0: Output will, if switched on, be dimmed with voltage according to CV #60.<br>Respective Bit = 1: Output will, if switched on, not be dimmed, i.e. it will be supplied with full voltage when switched on.<br><u>EXAMPLE:</u><br>CV #114 = 60: FO1, FO2, FO3, FO4 will <b>not</b> be dimmed; i.e. only the headlights are reduced in brightness. |
| #152 | Dim Mask 2<br><br>Excludes specific function outputs from dimming<br><br>Addition to CV #114<br><br>and<br><br>FO3, FO4 as Direction outputs | Bits 0 - 5<br><br>and<br><br>Bit 6,<br>Bit 7 | 0<br><br>0 | ... Addition to CV #114.<br>Bit 0 - function output FO7,<br>Bit 1 - function output FO8,<br>Bit 2 - function output FO9,<br>Bit 3 - function output FO10,<br>Bit 4 - function output FO11,<br>Bit 5 - function output FO12.<br>Bit 6 = 0: “normal”<br>= 1: Direction bits on FO3, FO4, i.e.<br>FO3 is switched on when driving backwards,<br>FO4 is switched on when driving forward.<br>(for Märklin switch type C)<br>Bit 7 = 1: direction bit for FO9 when driving forward  |



**Low/high beam mask with the low beam mask**

One of the function keys F6 (CV #119) or F7 (CV #120) can be defined as a low beam key. Selected function outputs can be dimmed as required with the function turned ON or OFF (inverted action with Bit 7).

| CV   | Denomination   | Range      | Default | Description   |
|------|--|------------|---------|---|
| #119 | Low beam mask for F6<br>=<br>Allocation of Function outputs as (for example) low/high beam<br>ATTENTION:<br>Certain settings in CV #154 (Special output configurations for OEM projects) the meaning of the following CVs changes: #119, #120, i.e. those are not low beam mask anymore. | Bits 0 - 7 | 0       | Selected outputs will dim, according to the dim value in CV #60, when the F6 key is actuated.<br>Typical application: Low/high beam<br>Bit 0 - front headlights<br>Bit 1 - rear headlights<br>Bit 2 - function output FO1,<br>Bit 3 - function output FO2,<br>Bit 4 - function output FO3,<br>Bit 5 - function output FO4,<br>Bit 6 - function output FO5.<br>Respective Bit = 0: Output will not be dimmed,<br>Respective Bit = 1: Output will be dimmed with F6 to value defined in CV #60.<br>Bit 7 = 0: "normal" effect of F6.<br>= 1: Inverted effect of F6.<br><u>EXAMPLE:</u><br>CV #119 = 131: Headlights shall be switched between high and low beam with F6 (F6 = 1). |
| #120 | Low beam mask for F7   | Bits 0 - 7 |         | Same as CV #119 but with F7 as low beam key.  |

**A "second dim value" with the help of the uncoupler CV**

If more function outputs need to be dimmed than CV #60 allows or if some function outputs require a different voltage and the uncoupler function is not needed on the same vehicle, then

**CV #115**

can be used as alternative dimming configuration. The respective function outputs must be defined as "uncoupler output" in the corresponding

CVs #127 - #132, #159, #160

(see "Special effects for function outputs").

| CV                             | Denomination  | Range | Default | Description  |
|--------------------------------|---|-------|---------|--|
| #115                           | (Uncoupler control Activation time)<br>or<br>"Second dimming value" | 0 - 7 | 0       | Valid, if the effect "ncoupling" is configured in Cvs #127 - #132, #159, #160.<br>Tens digit = 0: when used for dimming applications<br>Ones digit (0 to 9): PWM reduction (0 to 90 %) |
| #127 -<br>#132<br>#159<br>#160 | Effects<br>on FO1, FO2<br>FO3, FO4, FO5, FO6<br>on FO7, FO8         |       | 0<br>0  | = 48 when used to dim<br>#127 → FO1    #128 → FO2<br>#129 → FO3    #130 → FO4<br>#131 → FO5    #132 → FO6  |

|  |  |  |  |                          |
|--|--|--|--|--------------------------|
|  |  |  |  | #159 → FO7    #160 → FO8 |
|--|--|--|--|--------------------------|

**3.20 Flasher Effect**

Flashing is actually a lighting effect just like all the others that are summarized in the CVs starting with #125; for historical reasons though they are listed with their own CVs #117 and #118.

| CV   | Denomination  | Range      | Default | Description   |
|------|---|------------|---------|---|
| #117 | Flasher functions<br>Outputs are assigned in CV #118.<br>Flashing mask              | 0 - 99     | 0       | Duty cycle for flasher function:<br>Tens digit: Off / Ones digit: On<br>(0 = 100msec, 1 = 200msec.....9 = 1 sec)<br><u>Example:</u><br>CV #117 = 55: Flashes evenly at 1 a second interval. i.e. identical on and off times   |
| #118 | Flashing mask<br>=<br>Allocation of Function outputs to the flashing rhythm CV #117 | Bits 0 - 7 | 0       | Selected function outputs will flash when turned ON.<br>Bit 0 - front headlights<br>Bit 1 - rear headlights<br>Bit 2 - for function output FO1, Bit 3 - ...FO2<br>Bit 4 - for function output FO3, Bit 5 - ...FO4<br>Respective Bit = 0: No flasher<br>Respective Bit = 1: Output flashes when turned ON.<br>Bit 6 = 1: FO2 flashes inverse<br>Bit 7 = 1: FO4 flashes inverse (for alternate flashing, i.e. wig-wag)<br><u>EXAMPLES:</u><br>CV #118 = 12: Function outputs FO1 and FO2 are assigned for flashing lights.<br>CV #118 = 168: Outputs FO2 and FO4 shall flash alternatively, if both are turned on |



### 3.21 Effects for function outputs (US and other lighting effects, smoke generators, uncouplers, etc.)

“Effects” can be assigned to up to 15 function outputs in total, this is done with

CVs #125, #126, #127 ... #132, #159, #160, #195 ... #199  
for Front light, Rear light, FO1 ... FA6, FA7, FA8, FO9 ... FO13

The values programmed into those effect CVs consist of

the actual 6-bit - effect - Code and the 2-bit - direction- code

Bits 1,0 = 00: direction independent (always active, effect code without addition)  
= 01: only active in forward direction (effect code +1)  
= 10: only active in reverse direction (+2)

Each CV #125, #126, ...

- Bits 7 ... 2 = 000000xx no effect, **only** direction = (0), 1, 2
- = 000001xx Mars light + direction = 4, 5, 6
- = 000010xx Random flicker (e.g. charcoal flickering) + direction = 8, 9, 10
- = 000011xx Flashing headlight + direction = 12, 13, 14
- = 000100xx Single pulse strobe + direction = 16, 17, 18
- = 000101xx Double pulse strobe + direction = 20, 21, 22
- = 000110xx Rotary beacon simulator + direction = 24, 25, 26
- = 000111xx Gyalralite + direction = 28, 29, 30
- = 001000xx Ditch light type 1, right + direction = 32, 33, 34
- = 001001xx Ditch light type 1, left + direction = 36, 37, 38
- = 001000xx Ditch light type 2, right + direction = 40, 41, 42
- = 001001xx Ditch light type 2, left + direction = 44, 45, 46
- = 001100xx Uncoupler: time/voltage threshold = 48, 49, 50  
in CV #115, automatic disengagement in CV #116
- = 001101xx “Soft start” = slow brightening up of function output = 52, 53, 54
- = 001110xx Automatic stoplights for trams, delay at standstill variable,  
Stoplight-off delay see CV #63. = 56, 57, 58
- = 001111xx Function output turns itself off at speed > 0  
(i.e. turns off cab light when driving) = 60, 61, 62.
- = 010000xx Automatic output turns itself off automatically after 5 minutes = 64, 65, 66  
(i.e. to protect smoke generators from overheating).
- = 010001xx As above, but after 10 minutes = 68, 69, 70
- = 010010xx Speed or load dependent **smoke generation** = 72, 73, 74  
for **STEAM locos** according to CVs #137 - #139 (heating during standstill, heavy smoke at high speed or load). Automatic turn-off, as per CV #353;  
after turn-off only available by reactivating the function.
- = 010100xx Driving state-dependent **smoke generation** for **diesel engines** = 80, 81, 82  
according to CVs #137 - #139 (heating during standstill, heavy smoke during motor start-up sound and acceleration). Synchronized control of fan connected to the fan output.  
Smoke turns off automatically as per CV #353; function key must be pressed to reactivate smoke.
- = 010110xx slow brightening up & slow dimming of a function output; useful for various lighting effects or motor-controlled consumers (e.g. for fans or snow blower-wheels). = 88, 89, 90  
Dimming and brightening up times in CVs #190, #191!
- = 011000xx sparks with heavy braking = 96, 97, 98
- = 011010xx Dimming - Setting the dimming value in CV #192 = 104, 105, 106

- Effect CVs **without effect** (effect code 000000) produce **direction dependent function outputs**

EXAMPLE: CV #127 = 1, CV #128 = 2, CV #35 = 12: FO1, FO2 operate directional, ON/OFF with F1 key.

Note regarding ditch lights: those are only active, if the headlights (F0) and function F2 are turned on; this corresponds to the American prototype. The ditch lights will only be working if the applicable bits in CV #33 and #34 are on (the definition in CV #125 - #128 in itself is not enough but a necessary addition). Example: If ditch lights are defined for FO1 and FO2, the bits 2 and 3 in CV #33 and 34 have to be set accordingly (i.e. CV #33 = 13 (00001101), CV #34 = 14 (00001110)).

| CV          | Denomination   | Range                         | Default | Description  |
|-------------|--|-------------------------------|---------|--|
| #125        | Effects  |                               | 0       | Bits 1, 0 = 00: bidirectional (active in both directions)<br>= 01: only active in forward direction<br>= 10: only active in reverse direction  |
| #125        | American Lighting effects, and other effects, Couplings, smoke generators, etc. on the function output “Front light”, Configurations and Modifications of the effects by CVs #62, #63, #64, and CV #115, #116 (for coupler). |                               | 0       | <b>ATTENTION</b> in case of CV #125 and #126: change CVs #33, #34.... if direction is wrong!<br>Bits 7, 6, 5, 4, 3, 2 = Effect-Code<br>EXAMPLES (Effect - value programmed into CV #125)<br>Mars light forward only - 00000101 = 5<br>Gyalralite independent of direction - 00011100 = 28<br>Ditch type 1 left, only forward - 00100101 = 37<br>Uncoupler - 00110000 = 48<br><b>Soft start of output</b> - 00110100 = 52<br><b>Autom. brake light</b> - 00111000 = 56<br>Autom. Cab light OFF - 00111100 = 60<br>Speed/load depen. smoke - 01001000 = 72<br>Speed/load dependency diesel smoke - 01010000 = 80 |
| #126        | Effects on function output rear light  |                               | 0       | See CV #125 for details<br>#125 → Front headlight<br>#126 → Rear headlight   |
| #127 - #132 | Effects on FO1, FO2, FO3, FO4, FO5, FO6  |                               | 0       | See CV #125 #127 → FO1 #128 → FO2 #129 → FO3 #130 → FO4 #131 → FO5 #132 → FO6  |
| #159, #160  | Effects on FO7, FO8  |                               | 0       | like CV #125 #159 → FO7 #160 → FO8   |
| #195 - #199 | Effects on FO9, FO10, FO11, FO12, FO13   |                               | 0       | like CV #125 #195 → FO9 #196 → FO10 #197 → FO11 #198 → FO12 #199 → FO13  |
| #62         | afterglow brake light  | 0 - 255                       | 0       | Brake light (code 001110xx in CV #125ff): Afterglow in tenths of a second (i.e. range 0 to 25 sec) at standstill after stopping  |
| #63         | Modifications of lighting effects  | 0 - 99                        | 51      | Tens digit: Changing cycle time for various effects (0 - 9, default 5), or brightening up at soft start at 001101 (0 - 0.9 sec)<br>Ones digit: Extends off-time  |
| #64         | Ditchlight modifications   | 0 - 255                       | 0       | Bit 7 - 4: define a ditch light key (function key+1)*16 consequent: 0=F2, 1=F0, 2=F1,... 15=F14<br>Bit 3 - 0: Ditch light OFF time modification [s]  |
| #393        | ZIMO Config 5  | 0 - 3                         | 0       | Bit 0 = 1: Activate ditch light if bell is played<br>Bit 1 = 1: Activate ditch light if horn is played   |
| #190        | Brightening-up time for effects 88, 89 and 90  | 0 - 100<br>101-200<br>201-255 | 0       | The range 0 - 100 equals 0 - 1 sec (10ms/value)<br>101 - 200 1 - 100s (1s/Wert)<br>201 - 255 100 - 320s (4s/Wert)  |
| #191        | Dimming time for effects 88, 89 and 90   | 0 - 100<br>101-200<br>201-255 | 0       | The range 0 - 100 equals 0 - 1 sec (10ms/value)<br>101 - 200 1 - 100s (1s/Wert)<br>201 - 255 100 - 320s (4s/Wert)  |
| #192        | Value for effect dimming   | 0 - 255                       | 0       | Code 011010xx in CV #125ff: Decreases the brightness of the (light) function output by the set value (in percent), (e.g. value 127 = 50 %)   |
| #353        | Automatic turn-off of the smoke generator  | 0 - 255<br>= 0 - 106 min      | 0       | For effects “010010xx” or “010100xx” (smoke generator): over-heating protection: Turn-off ½ min to 2h.<br>= 0: no automated shut-down<br>= 1 to 255: automatic turn-off after 25sec/unit   |





### 3.22 Configuration of Smoke Generators

#### Smoke generator without fan (Example: Seuthe 18 V):

In addition to a simple ON/OFF function via a function output of your choice, the smoke intensity can also be programmed to change between **standstill**, or **cruising** and **acceleration**.

Therefore, the smoke generator must be connected to one of the function outputs **FO1 - FO8** and the selected output must be programmed with the associated "effect CV" (with CV #127 for FO1, CV #128 for FO2 etc.); in this case smoke generation of steam engines (effect code "72") or diesels (effect code "80").

The smoke generator characteristic as defined by CV #137, #138 and #139 is used for the relevant function output.

Those CVs must be programmed (with appropriate values) otherwise the smoke generator will not produce any smoke.

**EXAMPLE:** Typical characteristic for a track voltage set around 20 V with above smoke generator (18 V):

CV #137 = 70 – 90: Little smoke at standstill.

CV #138 = 200: The smoke intensity is increased to about 80 % of its maximum capacity beginning with speed step 1 (at very low speed), which produces relatively heavy smoke.

CV #139 = 255: The smoke generator is driven to its maximum under acceleration, which results in thick smoke.

#### Synchronized steam chuffs or typical diesel smoke (with exhaust fan):

The heating element of the smoke generator is connected – as in the example above with the "Seuthe" generator – to **FO1 - FO8**. The fan is connected to the function output **FO4** (in some decoders on **FO2**).

See chapter "7 Installation and connection of the ZIMO decoder".

#### Small decoders:

fan is connected to **FA4** (against positive pole) (for this CV #133 = 1 is set).

#### Large decoders:

Fan could also be connected to output FA4, but it is considerably better to:

Use the **special outputs** Ventilator **V1** and **V2** (against **ground**). These outputs are advantageously designed for the purpose (unlike normal function outputs): working on 5 V basis (like the usual fan motors) and equipped with the possibility of braking between steam hammer pulses (which better separates the ejected steam clouds).

For **fan V1** (the only one used when there is only one smoke generator) there are settings in CVs #351, #352, #355 (see table below).

If **two smoke generators** are used, i.e. 2 heaters and 2 fans (whether in one housing or completely separated from each other), the two heaters are connected to different function outputs, both of which must be assigned the appropriate effect (VAPOR or DIESEL or possible future variants), e.g.

STEAM: CV #159 = 72 and CV #160 = 72 or DIESEL: CV #159 = 80 and CV #160 = 80

(Assuming that the two heating elements are connected to FA7, FA8)

The lower of the two function outputs (i.e. in the example the smoke generator on FA7) is then automatically assigned the first fan output (i.e. V1), the higher the second (V2).

For **fan V2** the setting CVs are in a separate CV page...

(Information will be added.)

| CV                   | Denomination   | Range                         | Default     | Description  |
|----------------------|--|-------------------------------|-------------|--|
| #133                 | Using FO4 as a normal function output or<br>FO4 as output for Steam fan of the Smoke generator of steam locos and<br>IN (reed) pins Configuration and<br>MS440: FA9 at pin IN4 |                               | 0           | = 0 (Default): FO4 is used as normal function output so it is controllable by function key instead of a cam sensor.<br>= 1: FO4 for smoke-fan which is usually controlled by a real or "virtual" cam sensor. Also see CVs #267, #268!<br><b>NOTE:</b> The fan operation is also determined by the sound project.<br><b>NOTE:</b> Large-scale decoders do have special outputs and additional configuration possibilities for smoke fans!<br>Bit 4 - Input IN1 is inverted<br>Bit 3 - Input IN2 is inverted<br>Bit 2 - Input IN3 is inverted<br>Bit 5 - Input IN4 is inverted<br>Bit 6 - (only type MS440) Pin IN4 becomes output FA9 |
| #137<br>#138<br>#139 | Definitions of Smoke generator characteristic, connected to FO1 – FO8.<br>PWM at stand still<br>PWM at steady speed<br>PWM during acceleration                                 | 0 - 255<br>0 - 255<br>0 - 255 | 0<br>0<br>0 | This is valid, if in one of the CVs #127 - #132 has set on of the function effects "smoke generation" (i.e. "72" or "80"): The values in CVs #137 – #139 define a characteristic for the function outputs (FO1 - FO8; referred to below as FOx).<br>CV #137: PWM of FOx at standstill<br>CV #138: PWM of FOx at steady speed<br>CV #139: PWM of FOx at acceleration  |
| #351                 | Speed of the smoke fan at constant speed for DIESEL locos  | 1 - 255                       | 128         | The speed of the fan is set by PWM; the value of CV #351 defines the behavior during normal driving.<br>= 128: Half voltage (PWM) when driving.  |
| #352                 | Speed of the smoke fan during acceleration and engine starting for DIESEL locos  | 1 – 255                       | 255         | To create a cloud of smoke when starting the engines, the fan is set to higher (usually maximum) speed, also in case of strong acceleration during operation.<br>= 255: Maximum voltage during start-up.   |
| #355                 | Speed of the smoke fan at constant speed for DIESEL locos  | 1 – 255                       | 0           | CV #355 sets the speed of the fan at standstill - with sound on. This has the effect of emitting smoke (a small amount, but visible) even at standstill.   |

#### Decoder with 2 smoke fans (e. g. MS950, MS990)

For the second fan (V2) are

**CV page 145/0** (i.e. page pointer CV #31 = 145, CV #32 = 0), **CVs #500 - #511**

(if necessary also for several other fans) available. The second fan is automatically assigned to the higher function output with effect "smoke generation" (i.e. where second heating element is connected).

| CVs (from SW-Version 5)   | Description   |
|---|---|
| Select page:<br>CV #31 = 145, CV #32 = 0<br><b>CV-Page 145/0 &gt;</b><br>CVs #501, 502, 505 | <b>SW version 5.00 or higher</b><br>Identical meaning as CV page 0 (main page) > CVs #351, #352, #355 (there for fan V1), but fan -output V2. |



### 3.23 Configuration of Electric Uncouplers

#### System KROIS" and "System ROCO"

If one or two of the function outputs **FO1 - FO8** is assigned to the uncoupler function (CV #127 for FO1 etc.), the control of the couplings as well as the entire uncoupling process is defined by

#### CVs #115 and #116

These CVs limit the time it is switched on (to prevent overheating), define a hold-in voltage if required (i.e. System "Roco") as well as the automated coupling unloading and train disengagement.

It is recommended to use the following settings for the **Krois system: CV #115 = 60, 70 or 80**; these settings will limit the pull-in time (at full track power) to 2, 3 or 4 seconds respectively.

| CV   | Denomination   | Range                    | Default | Description  |
|------|--|--------------------------|---------|--|
| #115 | Uncoupler control Activation time<br>or<br>CV #115 can be used as alternative "second dimming value."<br>(Dimming 0% - 90% using ones digit; tens digit must be 0) | 0 - 99                   | 0       | The uncoupler function is only active if "uncoupler" is selected (value 48) in one of the CVs #125 - #132, #159, #160:<br>Tens digit (0 - 9): Time in seconds the coupler receives full voltage (pull-in time):<br>Value: 0 1 2 3 4 5 6 7 8 9<br>sec: 0 0.1 0.2 0.4 0.8 1 2 3 4 5<br>Ones digit (0 to 9): PWM - voltage reduction (0% to 90%) to control the coupling during the pull-in time (ROCO coupling, not KROIS).  |
| #116 | Automatic Disengagement during uncoupling<br>=<br>"Automatic uncoupling"   | 0, 1 - 99,<br>0, 1 - 199 | 0       | Tens digit (0 - 9): Length of time the loco should move away (disengage) from the train; coding as in CV #115.<br>Ones digit (1 - 9) x 4 = Internal speed step applied for disengagement (Acceleration per CV #3)<br>Ones digit = 0: Standstill<br>Hundredths digit<br>= 0: No unloading.<br>= 1: Coupler unloading: engine moves toward train in order to relieve coupler tension, before uncoupling and disengaging from the train.<br><b>EXAMPLE:</b><br>CV #115 = 60 (driving off after disengagement for 2 sec), and<br>CV #116 = 155 (active pushing to disengage, speed step 20, 1 sec) |

#### Notes to automated uncoupling with coupler-unloading and train disengagement

- The automatic train disengagement is active if the tens digit in CV #116 is other than 0; if desired with prior coupler unloading (when CV #116 > 100).
- The automatic train disengagement (or the preceding coupler unloading) is started at the same time the coupling is activated, but only if the train is standing still (speed 0); if the train is still moving, the uncoupling, unloading and disengagement procedure will not start until the train comes to a full stop.
- The procedure terminates when the "temporary" function key is released (or pressed again if in latched mode), or when the predetermined times (CV #115 for the coupling, CV #116 for the disengagement) have expired.
- The uncoupling and disengagement process is aborted immediately if the speed regulator is operated at the same time.
- The driving direction for the train disengagement is always according to the direction set; directional settings in the "special effects" definition for uncoupling will not be applied.

### 3.24 SUSI pins: switchable to SUSI or I<sup>2</sup>C interface, logic level inputs and outputs or servo control lines.

The "SUSI pins" described in this manual are multi-functional; they can be used either as SUSI interface, as I2C interface, as logic level outputs or inputs or as servo control lines \*. The "SUSI pins" are located on PluX or MTC connectors, or (for wired types) on solder pads, see connection diagrams, chapter "Technical.Data, ...".  
\*) In case of "small" decoders (H0, N, TT, etc.) the SUSI pins in alternative application are the only possibility to connect servos; large scale decoders on the other hand have dedicated servo pins; only if these are not sufficient, the SUSI pins are used for additional two servos.

By default, the SUSI data and clock lines are active on the "SUSI pins", in case, **logic level outputs** shall be active instead, set **CV #124 Bit 7 = 1 (value 128)** (Bit 7 in add.to other possibly set bits)

These logic level outputs are then always numbered as those following the "normal" outputs: e.g. on an MS450 which has 10 "normal" function outputs (Lfor, Lrev, FO1 - FO8), the logic level outputs are addressed as FO9, FO10, whereas on an MS440 they are addressed as FO7, FO8.

The CVs listed below define all alternative uses of the "SUSI pins". In factory default state (unless otherwise specified by Sound-Project) these CVs are normally set = 0, so that the "SUSI-Pins" actually form the SUSI interface. In the query order of the CVs the following applies:

**the first CV <> 0 (or bit 5 in CV #393) determines the application**; subsequent CVs have no effect.

Order: logic level outputs / logic level ("reed") inputs / I<sup>2</sup>C interface / servo control lines / SUSI

| query | CV  | Denomination   | Range                          | Default | Description   |
|-------|---|--|--------------------------------|---------|---|
| 1.    | #124  | Shunting key functions (not in use)<br>Switch SUSI - logic level outputs       | Bits 0 - 4, 6, 5, 7            | 0       | Bits 0 - 4, 6: Selection of a shunting key to ACTIVATE HALF SPEED:<br>Bit 5 = 1: "DC stopping"<br>Bit 7 = 0: SUSI-interface active<br>= 1: Logic level function outputs instead of SUSI<br>Entries in the following CVs thus have no effect.  |
| 2.    | #393  | ZIMO Config 5 switch inputs  | Bit 5                          | 0       | Bit 0 - Bit 4: various sound settings (see chapter 5.6)<br>Bit 5 = 1: reed switch inputs activated instead of SUSI<br>Entries in the following CVs thus have no effect.<br>Bit 6 = 1: 4x extension of the steam interval  |
| 3.    | #394  | ZIMO Config 4  | Bit 2                          | 0       | Bit 2 = 1: I <sup>2</sup> C activated instead of SUSI.<br>Entries in the following CVs thus have no effect  |
| 4.    | #181<br>#182<br>#183,<br>#184                   | for Servo 1,<br>for Servo 2,<br>for Servo 3,<br>for Servo 4.                   |                                | 0       | Settings for operation of the first 4 servos: see chapter "3.25 Servo Configuration".<br>If it is a "SUSI pin", it will be redefined to servo control line at the same time: for "small" decoders servo-1 and servo-2 to "SUSI pins", for large scale decoders the last ones (e.g. -7 and -8 for MS990 > 0: Servo control line to "SUSI-Pin |
|       | <b>ATTENTION:</b><br>Autom. adjustment possible | <b>Alternative (to be preferred for new projects) Setting the "SUSI" appl.</b> | (0), 11, 22, 33, 44, 55        | 0       | = 11: SUSI pins as logic level outputs (see above)<br>= 22: SUSI pins as logic level ("reed") inputs<br>= 33: SUSI pins as servo control lines<br>= 44: SUSI pins as "SUSI pins" (same as 0)<br>= 55: SUSI pins as I2C bus.   |
|       | #201  |  |                                |         |   |
|       | #202  | If decoder (large railroad decoder) has two "SUSI" connections                 | 0, 11, 22, 33, 44, 55          | 0       | As above (CV #201), but for second SUSI connection; there, however, CV #202 is the only setting option, not just the alternative).  |
|       | #203,<br>#204                                   | Use of the inputs IN1 & IN2, or IN3 & IN4                                      | Ones and tens digit 0, 1, 2, 4 | 0       | = 11: both "IN"s as logic level outputs (see above)<br>= 22: both "IN"s as logic level ("reed") inputs<br>= 44: both "IN"s as input for axis detector<br>CV #203 ones digit: IN1, tens digit: IN2<br>CV #204 ones digit: IN3, tens digit: IN4   |



### 3.25 Servo Configuration

| CV  | Denomination  | Range   | Default  | Description  |
|---|---|---|--|--|
| #161  | Servo outputs: Protocol<br>and alternate Use of Servo outputs: 3 & 4 as SUSI pins   | 0 - 3<br>Note: For <b>Smart Servo RC-1</b> set CV #161 = 2! | 0  | Bit 0 = 0: Servo protocol with positive pulses.<br>= 1: Servo protocol with negative pulses.<br>Bit 1 = 0: Control wire only active during movement<br>= 1: ... always active (draws current, judders sometimes but holds the position also at mechanical load);<br>Bit 2 = 0: For two-key operation (as per CV #181, ...) with center position, if none of the two keys is activated.<br>= 1: For two-key operation (as per CV #181, ...), where the servo runs only as long as function keys are active.   |
| #162<br>#163<br>#164<br>#165                  | Servo 1<br>Left position<br>Right stop<br>Center position<br>Rotating speed   | 0 - 255   | 49= 1 ms Servo pulse<br>205<br>127<br>30 = 3 sec | End positions and center position define the portion of the total rotation range of the servo to be used (typ. approx. 270°).<br>"left", "right" are to be understood symbolically; actual effect can also be exactly the opposite.<br>Speed of the actuating movement: Time between the defined end positions in tenths of a sec (i.e. range up to 25 sec, default 3 sec).  |
| #166 - #169<br>#170<br>#173<br>#174<br>- #177 | Same as above, but for: servo 2<br>servo 3<br>servo 4   |   |  |  |
| #178  | Panto Reverberation<br><i>as of SW version 4.210</i>  | 0 - 255   | 0  | Valid for each servo, which is valid as "Panto..." under CVs #181 - #184 (function assignments) = 94 - 97). After reaching the final position (i.e. after "Panto lift") the panto should move slightly up and down a few more times. CV #178 sets the amplitude of this oscillation (more precisely the first one)<br>= 0: no oscillation<br>= 50: sensible initial setting, vary from there.  |
| #181<br>#182<br>#183<br>#184                  | Servo 1<br>Servo 2<br>Servo 3<br>Servo 4<br>Function assignm.<br><br><b>NOTE:</b><br>If a servo control line shares its connection with another function (e.g. SUSI or input) for optional use, a value >0 in CV #181, #182, ... means switching to servo control line.<br>This concerns with "small" decoders (track N ... H0) the "official" SUSI pins, which are switched to | 0 - 28<br><br>90 - 97*<br><br>101-114<br>201-208            | 0<br>0<br>0<br>0                                 | = 0: Servo not in operation<br>= 1: Single-key operation with F1<br>= 2: Single-key operation with F2 and so on..<br>= 28: Single-key operation with F28<br>= 90: servo dependent on loco direction forward = servo left; reverse = servo right<br>= 91: servo dependent on loco direction and standstill i.e. servo on the right at standstill and direction forward, otherwise servo on the left<br>= 92: servo dependent on loco direction and standstill i.e. servo on the right..backwards, left<br>= 93: servo dependent on standstill or cruising i.e. servo on the right at standstill, servo on the left at cruising; direction without effect.<br>= 94: refers to function "Panto1" which is configured in CV #186.<br>= 95: ..."Panto2" configured in CV #187<br>= 96: ..."Panto3" configured in CV #188<br>= 97: ..."Panto4" configured in CV #189<br>= 101: Two-key operation F1 + F2 |

|                              |  |                       |   |  |
|------------------------------|--|-----------------------|---|--|
|                              | servo with CVs #181, #182 (SUSI no longer available), with MS950, MS955 servos 3 + 4, with MS990 7 + 8.                                  |                       |   | = 102: Two-key operation F2 + F3 and so on..<br>= 111: Two-key operation F11 + F12<br>= 112: Two-key operation F3 + F6<br>= 113: Two-key operation F4 + F7<br>= 114: Two-key operation F5 + F8 (Two-key mode as defined with CV #161, Bit 2)<br>= 201 - 208: Events 1 - 8 from scripts or sound  |
| #185                         | Special assignment for live steam engines<br><b>NOT implemented</b> in MS decoders until further notice (CV reserved for potential need) |                       | 0 | = 1: Steam loco with one servo in operation; speed and direction of travel defined by slider, center position means stop.<br>= 2: Servo 1 proportional on speed regulator Servo 2 for direction.<br>= 3: like 2, however: Direction-servo is automatically in "neutral" if speed is 0 and F1 = ON;<br>At speed step > 0: if direction-servo is engaged.<br><b>NOTE</b> to CV #185 = 2 or 3: Servo 1 is adjustable with CV #162, #163 (end-positions), by using the corresponding values, it is also possible to change the direction.<br>Servo 2 is adjustable with CV #166, #167. |
| #186<br>#187<br>#188<br>#189 | "Panto1"<br>"Panto2"<br>"Panto3"<br>"Panto4"   |                       | 0 | Bit 7 = 0: Not sound-dependent<br>= 1: Sound-dependent<br>Bit 6 - 5 = 00: direction independent,<br>= 01: only if loco drives forward<br>= 10: only if loco drives backwards<br>= 11: only if F-key is turned off<br>Bit 4 - 0: to Activate<br>00001 = F1 00010 = F2 00011 = F3, ...   |
| #201                         | Alternative (clearer, preferred for new projects) "SUSI" usage.  | 0, 11, 22, 33, 44, 55 | 0 | = 11: SUSI pins as logic level outputs (see above)<br>= 22: SUSI pins as logic level ("reed") inputs<br>= 33: SUSI pins as servo control lines<br>= 44: SUSI pins as "SUSI pins" (same as 0)<br>= 55: SUSI pins as I2C bus.  |

#### IMPORTANT NOTE for connecting the servos to "non-large scale" decoders

The possibility to connect servo control lines is a secondary function of the "SUSI" pins (to be activated by CVs #181, #182). These work with a voltage level of 3.3 V (difference to MX decoders where the SUSI pins (and therefore also the control lines) work with 5 V).

**Some servos do NOT work with 3.3 V!** The technical data of the servos usually do NOT show this restriction!

Possible remedy for non-function: lower supply voltage (normally 5 V) to about 4 V; otherwise only exchange helps; better are digital servos (avoid also jerks at the beginning etc.)

#### Decoders with more than 4 (i.e. 5 to 8) servo control lines (e.g. MS990)

**CV-Page 145, CVs #262 - #284** are available for the servo control lines 5 - 8. It is insignificant whether complete servo connections are involved (e.g. a total of 6 servo connections on the MS990) or individual servo control lines, for example as a secondary function of SUSI pins.

| CVs (from sw version 4.90)  | Description  |
|---|--|
| Select page: CV #32 = 145<br><b>CV-Page 145 &gt;</b> CVs #262 - #277, #281 - #284 | For large scale decoder, if more than 4 servos can be operated: Identical meaning as CV page 0 (main page), CVs #162 - #177 resp. #181 - #184, but for <b>servo control lines 5 to 8</b> (instead of 1 to 4) |



### 3.26 Additional CVs for large scale and special decoders

| CV   | Denomination  | Range    | Default      | Description   |
|------|---|----------|--------------|---|
| #264 | Variable low voltage (large scale and special decoders) | 10 - 158 | 15 (= 1.5 V) | Variable (adjustable by CV) low voltage (only large scale and some special decoders) = 10 - 158: Low voltage in tenths of a volt (1-15.8 V) |

## 4 RailCom - "Bidirectional communication" for DCC

"Bi-directional" means that within the framework of the DCC protocol there is a flow of information not only in the direction of the decoders, but also in the opposite direction; i.e. not only run commands, function commands, control commands, etc. to the decoders, but also feedback messages such as reception confirmations, speed measurements, other status information and CV readouts from the decoders to the digital control centre or "local detectors".

ZIMO decoders of all types (as well as digital command stations and track detectors as receiving devices) were already equipped with a proprietary form of "bi-directional communication" since the 1990s (long before RailCom) - the "ZIMO loco number identification". At that time, this was a significant difference to competitor products. In layouts with MX9 track section modules built until 2010, ZIMO loco number identification continues to be used, as **MX9 modules do NOT work with "RailCom"** (but the subsequent "StEin" modules do).

Since 2005 (shortly after the introduction by Lenz) all ZIMO decoders are equipped for the in the meantime **standardized feedback protocol "RailCom"** (RCN-217 at RailCommunity - VHDM - and S-9.3.2 at NMRA). RailCom also replaces the above-mentioned ZIMO train number identification.

The basic mode of operation of RailCom is based on the fact that the otherwise continuous energy and data stream, i.e. the DCC rail signal, which is applied to the track by the digital control centre, is interrupted by short potential-free gaps (the "RailCom cutouts", max. 500 microsec); in these gaps, the decoders can send out feedback information (as "RailCom messages", altogether - both channels together - up to 48 bits long), which are received and evaluated by "local detectors" (assigned to individual isolated track sections) or by the "global detector" in the digital centre itself, largely undisturbed.

Relevant CVs for basic RailCom configuration:

| CV  | Denomination                              | Range                  | Default  | Description   |
|-----|---|------------------------|--|---|
| #28 | RailCom Configuration                     | 0, 1, 2, 3, 65, 66, 67 | 3 resp. 67 with bit 6, High current  | Bit 0 - RailCom Channel 1 (Broadcast)<br>Bit 1 - RailCom Channel 2 (Data)<br>Bit 6 - High voltage RailCom (large scale decoders onl.)<br>for all Bits: 0 = OFF 1 = ON   |
| #29 | Basic configuration<br>Configuration data | 0 - 63                 | 14 = 0000 1110<br>Bit 3 = 1 (RailCom is switched on) and<br>Bits 1,2 = 1 (28 or 128 speed steps, and autom. analog mode) | Bit 0 - Train direction:<br>0 = normal, 1 = reversed<br>Bit 1 - number of speed steps<br>0 = 14, 1 = 28 speed steps<br>Bit 2 - automatic change to analog operation<br>0 = disabled 1 = enabled<br>Bit 3 - RailCom („bi-directional communication")<br>0 = deactivated 1 = activated<br>Bit 4 - Selection of speed characteristic:<br>0 = Three-point char. according to CV #2, #5, #6<br>1 = free characteristics acc. to CVs #67 - #94<br>Bit 5 - Decoder address selection (DCC):<br>0 = primary address as per CV #1<br>1 = ext. address as per CVs #17 & #18 |

| CV   | Denomination  | Range   | Default | Description   |
|------|---|---------|---------|---|
| #136 | Fine adjustment of the speed feedback or km/h – control number during calibration run | 0 - 255 | 128     | RailCom speed feedback correction factor.<br>or (see chapter 5.8 in manual for small decoders) reading out the result of the internally computed speed after the calibration run. |

In ZIMO decoders (now also in most third-party products) the RailCom functions are switched on by default. If this should not be the case, they are activated by:

CV #29, Bit 3 = 1 AND CV #28 = 3 (or = 67, if large scale decoder),  
if the speed feedback (tacho) should not work: CV #158, Bit 2 = 1  
or exceptionally (if MX31ZL as command station): = 0

In the first years after the introduction of RailCom, its potential was only used intensively for two purposes: for **address reporting** for isolated track sections (what the ZIMO loco number identification had previously done), and for **CV programming and reading** in operational mode (also called "PoM" = "Programming-on-the-Main"). This has changed - roughly since 2015: **DCC decoders without RailCom are now hardly imaginable.**

Briefly summarized, the "RailCom" tasks can be structured like this:

- **All RailCom responses** (initially independent of the content of the message itself) confirm the receipt of the respective preceding DCC commands, which increases the operational reliability and the "bandwidth" of the entire DCC control. The latter is the case because acknowledged DCC commands do not have to be repeated.
- **"RailCom Channel 2"** (the second - with 36 bit larger part - of each RailCom total message): **Current data from the vehicle** are reported to the "global detector" of the digital control center via this channel, each time in response to a DCC command to its own decoder address; this includes, for example (depending on the design) the "real" (measured) speed, routing and position codes, simulated "fuel stocks", current values of the CVs on request (CV programming and reading in operational mode or "programming-on-the-main" - PoM).
- **"RailCom Channel 1"** (the first - smaller part with 12 bit): This is used to report (normally nothing else than) the **own decoder address**, in response to all DCC commands (i.e. especially those that do NOT address the own vehicle, therefore up to 100 times / sec). Since all decoders send out Channel 1 data at the same time, these can only be read on isolated track sections by "local detectors", if there is only one vehicle with a RailCom-activated decoder.

In the "global detector" of the command station, on the other hand, the simultaneous Channel 1 data of the different decoders overlap and are therefore not readable, which would not make sense anyway, since the addresses are only of interest locally (on the individual isolated track sections).

The above "short description" of RailCom technology refers only to the "normal" operations; in practice (even in the standards themselves) there are numerous deviations and exceptions in the channel allocations, etc.



#### *Constant further development of RailCom use:*

Since **new RailCom applications are constantly being created** and implemented in decoders and digital equipment, with ZIMO often taking a pioneering role, instruction manuals cannot always be kept up to date in this respect.

Therefore, here is only a short list of applications that have either already been realized, are currently in progress, or may be realized soon (in ZIMO decoders and systems):

#### **Classic applications:**

Address messaging (display on digit displays or computer interlocking), CV-programming and –reading, speed messages (to be displayed on the speedometer on the control unit), directional status messages (to be displayed forwards/backwards and east-west on the controller and automatic control interventions).

#### **Extended messages from the vehicles:**

These are currently mainly processed by ZIMO digital command stations and controllers.

Current (SW version 4.210):

- Direction status message (for displaying forward/backward as well as east-west direction on the operating device and automatic control interventions); according to RailCommunity standard: ID7, Sub-ID 27,
- ZIMO on-track search; according to RailCommunity standard: ID1, ID2, ID14 (after request to addr. 0),
- Quality-of-Service message, according to RailCommunity standard: ID7, Sub-ID 7,
- Track voltage at decoder location; according to RailCommunity standard: ID7, Sub-ID 46.

Planned:

HLU&ABC messages (for display on the controller and automatic control interventions), target distance and target speed (for display on "real" cabs), distance travelled, gradients, curves (decoder with sensors), height differences, turning angles, route profiles, current position, decoder-related data (motor current, temperature, ...).

#### **Advanced operational applications:**

ZIMO on-track search, address registration and assignment for new vehicles (according to RCN-218), GUI (Graphical User Interface) from the vehicle to the operating devices, transmission of large amounts of data from the vehicles and trains (e.g. track profile or prototype weights and measures of the carriages of a train), transmission of text messages from the train for display on the controller.

"RailCom" is a registered trademark of Lenz Elektronik GmbH.



## 5 ZIMO SOUND – Selection and Programming

**Sound projects**, Sound collections, free and chargeable projects, etc.

Specialties of the ZIMO sound organization over the traditional offerings from other manufacturers

► Each sound decoder requires a **sound project in the decoder's flash memory**. The sound project is basically a file, composed of the sound samples of a real locomotive (or several locomotives in the case of the "Sound Collection", see below), as well as playback instructions (in the form of schedules, dependencies on operating condition, speed, acceleration, pitch, etc.) and assignments (to function keys, random generators, switch inputs, etc.).

► Each ZIMO decoder comes loaded with a sound project (usually a "sound collection", see below). Further ZIMO sound projects for installation by the user can be loaded down from the **ZIMO sound database** at [www.zimo.at](http://www.zimo.at) in the form of "**Ready to use**" projects (.zpp file) and often, in addition to that, as "**Full featured**" projects (.zip file):

The "Ready to use" project is a **.zpp file**, which after downloading is uploaded to the decoder with the help of decoder update modules such as the MXULF, MX10 or MX10EC command station. The file is placed on a flash drive which is then plugged into the USB host socket of the mentioned modules or sent from a computer (connected to the USB client socket with the software **ZSP** installed on the PC) to the decoder. After the sound upload, many assignments and settings can be changed to suit individual tastes (even though it is a "ready-to-use" project), using the procedures and CVs described in the decoder manual.

The "Full featured" project on the other hand is a **.zip file** as downloaded from the sound database; it cannot be uploaded to the decoder directly but can only be unzipped and edited with the help of the "**ZIMO sound programmer**" **ZSP**. Assignments and settings can be determined within ZSP and it is also possible to remove sound samples for external processing or exchange them with others; it is therefore possible to create your own or highly individualized sound projects. The result is again a .zpp file that can be uploaded to the decoder (see above).

► ZIMO sound decoders are delivered preferably with a "Sound collection"; this is a special type of a sound project: sound samples and CV parameters for several engines (i.e. for 5 engines) are stored on each decoder. The preferred sound for a given locomotive can be selected with the controller (no need to load a different sound sample from the computer). (CV #265) The user is free to change acoustics of a locomotive to his/her own taste by combining for example a chuff sound from 5 different chuff samples and one or several whistles (selection is made using the "CV #300" procedure); equally select from

**NOTE:** Even normal sound projects ("normal" = for a specific locomotive) can comprise the characteristics of a "sound collection", by containing several whistles for example from which one can be selected using the "CV #300 procedure".

bells, compressors, coal shoveling, oil burners or break squeals etc.

Among the sound projects available from the ZIMO sound database, there is a difference between the

- "**Free D'load**" (= no charge) sound projects, often produced by ZIMO and the
- "**Coded**" (= purchased) sound projects, from external sound providers.

The "Coded sound projects" are contributed by external ZIMO partners (= providers, for example by Heinz Däppen for the Rhaetian Railway and American steam locomotives), who get reimbursed by the sale of "load codes". These fee-based projects can be downloaded for free from the ZIMO Sound Database, but can only be used in "**coded**" decoders, i.e. those in which the appropriate "**load code**" has been programmed beforehand. "Encoded decoders" can be purchased with the "load code" pre-installed (subject to a charge, see price list) or the load code is purchased later and entered to the appropriate

decoder CVs (CVs #260, #261, #262, #263). The "load code", which authorizes the use of sound projects of a specific sound supplier (i.e. the sound projects of Heinz Däppen) applies to one specific decoder which is identified by its decoder ID (CV #250, #251, #252, #253).

► In addition to the "Free D'load" and "Coded" projects, both of which are ready for download on the ZIMO Sound Database (see above), there is also the

- "**Preloaded**" sound projects: these are exclusively available as pre-programmed decoders and this in turn often only installed in new locomotives. "Preloaded" sound decoders are usually not provided by ZIMO, but by model railroad manufacturers and distributors, who are also responsible for setting the prices. These sound projects are merely listed in the ZIMO Sound Database as reference.

### Decoders with sound collection – How to select a loco type with CV #265

Implemented with SW-Version 4.00

using the example of the "European steam/diesel collection":

| CV   | Denomination           | Range                | Default  | Description  |
|------|------------------------|----------------------|--|--|
| #265 | Selection of Loco type | 1 - 32,<br>101 - 132 | 1 or<br>101<br><br>Type of steam loco = 1<br><br>or<br>Diesel loco = 101 | = 0, 100, 200: Reserved for future applications<br>= 1 - 32: Selection of diesel loco types<br>Sounds of steam locos in Sound Collection, e.g. for loco type BR50, BR78, BR03.10, etc. As well chuff sounds as well as other sounds (whistle, compressor, bell...) will be matched.<br><br>= 101 - 132: Selection of diesel loco types (if several diesel sounds are in the collection). |

Operating the sound decoder for the first time

with "European steam/diesel" sound collection:

At delivery, the decoder comes with a typical engine sound activated and function-sounds allocated to function keys, which can be played back in operation.

#### Function F8 – SOUND on/off

sounds played back with a function key remain active regardless whether F8 is on or off (a separate function key can be assigned with CV #311 to turn the function sound ON/OFF, which could of course also be F8!)

By default, the "European steam/diesel collection" plays back the sound of a 2-cylinder engine (the chuff rate can only be approximate without further tuning) with automated blow-off and brake squeal as well as some randomly played stationary sounds.

The **function keys** are allocated to the following function sounds:

|                                    |  |
|------------------------------------|--|
| F2 – short whistle                 | F10 – Dewatering cylinders                   |
| F3 – long whistle                  | F11 – Coupling / uncoupling / feed pump      |
| F4 – Conductor whistle             | F12 – Coal shoveling / air pump / compressor |
| F5 – Bell, Couplings               | F13 – Announcement / Water collection        |
| F7 – Curve squeal (only in motion) |  |

The **random sound generators** to ... stationary sounds:

|                    |                    |                                    |
|--------------------|--------------------|------------------------------------|
| Z1 – Air pump fast | Z2 – Air pump slow | Z3 – coal shoveling                |
| Z4 – Feed pump     | Z5 – Injector      | Z6 – Safety valves (stand + drive) |

The **switch inputs:** S1 – empty S2 – empty S3 – empty



**A sound project is composed of...**

... sound samples, schedules, and CV settings.

To produce the sound of a locomotive, the sound project contains the following components:

- 1) the **"main engine" sound**: this is the central sound, such as the chuff or diesel engine sound, or the cooling fan (which is the key sound in electric locomotive projects).

This "main engine" sound is the only sound component associated with a **schedule**, which defines important properties, especially the transitions between different sound samples in various speed, acceleration, and load situations.

This schedule can only be changed in the "ZIMO Sound Programmer" ZSP, not by CVs. However, there are numerous possibilities for **fine-tuning** the main engine sound **through CVs** (e.g. relation between chuff frequency and speed, lead-chuff accentuation, coasting/notching functions, etc.)

- 2) Other **scheduled sounds** (often inaccurately called background sounds): these are boiling, draining, turbocharger or brake squealing sounds and many others; also, in the case of electric locomotives the actual primary sounds of the thyristor unit and the electric motor.

"Scheduled" sounds - both the "main engine" and "other" - are characterized in that the decoder plays them automatically, based on the driving situation, while the "function sounds" (see below) are activated with the cab's function keys.

These "other" sounds (i.e. all except the "main engine" sound, see above) are NOT played according to a schedule, i.e. they are **fully defined by CVs, and can be modified** directly by the relevant CVs or CV #300 - procedures, even in operation (speed, load dependence, etc.). Only the underlying original recordings, that is, the sound sample or a selection of samples, is stored in the sound project (or in the sound collection).

- 3) The **function sounds**, which are played back by pressing the corresponding function keys includes acoustic signals such as whistles, horns, bells but also other sounds like coal shoveling, coupler clank, lowering of pantographs as well as station announcements.

The volumes of each sound and whether it is "looped" (for continuous playback as long as the function key is pressed) is **defined by CVs** but can also be **modified by these CVs** or with the CV #300 procedure. Here too, only the sound samples of the project or selections of several projects are predefined.

- 4) and 5) the **switch input** and **random sounds** are normally sounds that can also be used as function sounds but are triggered by switch inputs or random generators.

The occasionally used term "driving sound" refers to a subset of all the sounds, namely the "main engine" sound and most of the "other" sounds; the "departure whistle" sound for example is not included because it is not dependent on driving data.

**5.1 CV #300 - procedures**

SW version 5.00 or higher

*A more convenient procedure (w/o manual CV #300 programming) is available with MX31/MX32*

The term "CV #300 - procedure" means the use of CV #300, which allows the **modification of the currently loaded sound project** during normal operation, in relation to:

- the selection of sound samples within the various sound groups (i.e. "short whistle"), if it is a "sound collection" (which has several sound samples in some of its sound groups) or a "normal" sound project with several sound samples in certain groups.

the **volume** and the sound **loop** behavior of individual sounds; for example, setting the whistle volume different to the driving sound volume (i.e. chuff beats).

**NOTE:** If setting the volume of individual sound classes is the main concern, it is more convenient to use the direct CVs, see chapter "5.3 SOUND: Basic settings independent of powertrain"; in many applications the CV #300 procedure is therefore NOT needed.

**Selecting a chuff set** (if several sets are present in a sound collection):  
(only possible for steam projects, not for diesel or electrics)

The following procedures are always used in the same way despite the flexible decoder layout with different sound sample compilations. It is also worth mentioning that the sound samples can be listened to and evaluated under actual operating conditions (with the engine running), not just on the computer.

The **selection procedure** is started with a "Pseudo-Programming" in operations mode ("on-the-main"): **CV #300 = 100**

The "Pseudo-Programming" (meaning that the entered value is not really stored in memory) has the effect that the **function keys F0 to F8** no longer actuate function outputs but instead are now available for **special tasks** within the sound selection procedure. The function keys should be set to momentary, if possible, which would facilitate the procedure. **CV #300 procedures must be done in Operational Mode (on the main), NOT in Service Mode!**

The function key identifications (and the MX31/MX32 controller displays) shown are typical for a ZIMO controller during the selection procedures (and for other sound adjustment procedures) but is **analog to the function keys of third-party controllers**, although the keyboard layout may be different.

*The function keys have the following special meaning during the selection procedure!*

Key arrangement on the ZIMO MX31:

((( 1 F0 ((( 2 F1 ((( 3 F2  
 ((( 4 F3 ((( 5 F4 ((( 6 F5  
 ((( 7 F6 ((( 8 F7 ((( 9 F8

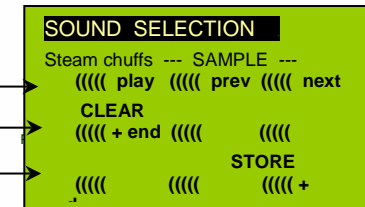

**F0** = play: plays back the current chuff sound for evaluation; only possible with the engine at a standstill; the chuff sounds are played back automatically when the engine is moving.

**F1, F2** = prev, next: plays back the previous or next recording, which is stored in the sound decoder

**F3** = CLEAR + end: The **selection procedure is stopped** and the selection is cleared, that is, no chuff sound will be played (but boiling and blow-off sound remains).

**F8** = STORE + end: The **selection procedure ends** and the current chuff set is replaced with the selected chuff set.

The **selection procedure** is also stopped when programming anything else (e.g. **CV #300 = 0**, or any other value or any other CV) or by interrupting power. In these cases, the **current chuff set remains**. Such "forced endings" are also useful when the "old" sound should remain as the current sound without first having to locate it again.

The selection procedure is supported with **sound signals**:

The **"cuckoo jingle"** sounds when....

- .... the last stored chuff sound is reached; use the key to scroll in the opposite direction (F1, F2) to listen to the other stored chuff sounds,
- .... play-back attempted (with F0) but no sound sample is available,
- .... a wrong key is pressed (F4, F5 etc.)

The **"confirmation jingle"** is played after ending the allocation procedure with F3 or F8.

The engines can be **operated normally** during the selection procedure: with speed regulator, direction key and MAN key (the latter only with ZIMO cabs); functions cannot be actuated until the selection procedure is terminated with F3, F8 or by other programming steps, see above.

**Selecting boiling, whistle, blow-off, brake squeal sounds...**

*within a sound collection or a sound project with several samples of this kind/for these classes:*



The **selection procedures** for these “automated background sounds” are initiated with an operational mode “Pseudo-Programming”

- CV #300 = 128 for the boiling sound (steam only)
- CV #300 = 129 for direction-change sound
- CV #300 = 130 for the brake squeal
- CV #300 = 131 thyristor-control sound (electric engine)
- CV #300 = 132 for the “start” whistle or horn
- CV #300 = 133 for blow-off sound =cylinder valves (STEAM only)

**NOTE:** the blow-off selection (CV #300 = 133) is also valid for function key playback (CV #312).

- CV #300 = 134 for the driving sound of ELECTRIC engines
- CV #300 = 135 for rolling noise
- CV #300 = 136 for the switchgear sound of ELECTRIC engines
- CV #300 = 137 for a second Thyristor sound (ELECTRIC engines)
- CV #300 = 141 for the turbo charger (DIESEL engine)
- CV #300 = 142 for the “dynamic brake” (Electric brake, ELECTRIC engines)

The selection procedure for background sounds is the same as for the selection of chuff sounds. EXCEPT: the engine should be at a **standstill** because the **speed regulator** is used for **setting the volume** of the relevant sound file!

**NOTE:** these sounds can also be allocated as function sounds allocated to function keys (see next page); the automated back-ground sounds can then be cancelled with the function keys.

((( 1 F0 ((( 2 F1 ((( 3 F2  
 ((( 4 F3 ((( 5 F4 ((( 6 F5  
 ((( 7 F6 ((( 8 F7 ((( 9

SOUND SELECTION  
 Boiling --- SAMPLE ---  
 play ((( prev ((( next  
 CLEAR --- CLASS ---  
 ((( + end ((( prev ((( next  
 STORE  
 ((( ((( ((( + end

The function keys have the following special meaning during the selection procedure!  
 Speed slider for volume control

Function keys similar to selection of chuff sounds:

- F0 = play: Playing back the selected sounds.
- F1, F2 = prev, next: Switching to previous or next sound sample.
- F4, F5 = prev, next: switches between sound groups, see right
- The **speed regulator** acts as volume control For the background sound during the selection procedure.
- F3 = CLEAR + end: The **selection procedure ends** and the current Background sound is turned off.
- F8 = STORE + end: The **selection procedure ends**;

SOUND SELECTION  
 Braking squeal --- SAMPLE ---  
 play ((( prev ((( next  
 CLEAR --- CLASS ---  
 ((( + end ((( prev ((( next  
 STORE  
 ((( ((( ((( + end

SOUND SELECTION |  
 Blow-off --- SAMPLE ---  
 play ((( prev ((( next  
 CLEAR --- CLASS ---  
 ((( + end ((( prev ((( next  
 STORE  
 ((( ((( ((( + end

The **selection procedure** can be **ended** by any other programming procedure or by removing power.

**Allocating sound samples to function keys F1 - F63**

within a sound collection or a sound project with several samples of this kind/for these classes

Each function or function key F1 - F19 can be assigned a sound sample from the pool of stored sound samples within the decoder, It is absolutely permissible to have a function key assigned for a function output (FO1, FO2 etc.) as well as for a sound function, both of which will be activated when the key is pressed. The switch input **allocation procedure** is initiated with the operations mode Pseudo-Programming

- CV #300 = 1 for function F1
- CV #300 = 2 for function F2
- etc.

**NOTE:** Function F4 is by default used for water drainage sound (with CV #312); if F4 is to be used for something different, CV #312 must be set to zero (CV #312 = 0).

CV #300 = 99 for function F0 (!)

The allocation procedure is very similar to the selection procedures for driving and background sounds, with the difference that sound allocation is not limited to sound samples of a certain group but also allows switching between groups to find the desired sample.

Sound samples are organized in **groups** for easier location; i.e. groups like “short whistle” / “long whistle” / “horn” / “bell” / “shoveling coal” / “announcements” and much more.

The engine should remain **stationary**, since the **speed regulator** is used for **volume settings** during the allocation procedure!

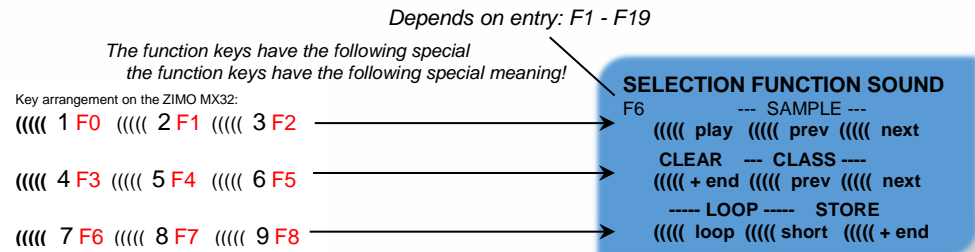

- F0 = play: plays back the current sound file for evaluation.
- F1, F2 = prev, next: Playback of previous or next sound sample, which is stored in the sound decoder
- F4, F5 = prev, next: Switches between sound groups (e.g. whistles, bells, coal shoveling etc.); starts playback with the first sample of this group.
- F6 = loop: If F6 is active when ending the allocation procedure: The sound sample shall be played back as long as the key is active, by repeating the part of the sample between the loop markers (they are included in the stored sound sample). *Playable whistle!*
- F7 = short: If F7 is active when ending the allocation procedure: The sound sample shall be shortened to the time, the key is active, by leaving out the part in the middle to the short marker.

F3 = CLEAR + end: The **selection procedure** is **stopped** and the selection is cleared, that is, from now on, this function key does not activate any sound.





**NOTE:** F6 and F7 are only effective, if the markers are included in the sound samples; basic settings are also saved; changes take effect only if F6/F7 is actuated.

If F6 and F7 are not set, the sound sample is played back in the stored length; with shorter and with longer activation of the F-keys.

**F8** = STORE + end: **F8** = STORE + end: The **allocation procedure** is **stopped** and the last selected function sound is stored and ready for playback when this function key is pressed.

The **allocation procedure** can also be **ended** by any other programming procedure (e.g. CV #300 = 0 or any other value or CV) or by removing power from the decoder. The "old" allocations remain active in such cases; such "forced endings" are also useful when the "old" sound should remain as the current sound without first having to locate it again.

The selection procedure is supported with **sound signals**:

The "**cuckoo jingle**" sounds when....

- .... the last stored sound sample of a group is reached; use the appropriate key (F1, F2) to scroll in the opposite direction to listen to the other stored sounds,
- .... the last stored sound group is reached (with F4 or F5); use the appropriate key (F4 or F5) to scroll in the opposite direction.
- .... play-back attempted (with F0) but no sound sample is available,
- .... a wrong key is pressed.

The "**confirmation jingle**" is played after ending the allocation procedure with F3 or F8.

**Allocation of sound samples to the random generators Z1 - Z8:**

MS sound decoders provide 8 simultaneously playing random sound generators. The timing of them is determined by CVs; see "CV table" from CV #315.

A sound sample can be added to each random generator from the pool of samples in the decoder.

The switch input **allocation procedure** is initiated with the operations mode Pseudo-Programming

- CV #300 = 101** for random generator Z1  
(Z1 has a special logic for the air brake pump; therefore, it should have an air brake pump allocated)
  - CV #300 = 102** for random generator Z2
  - CV #300 = 103** for random generator Z3
- etc.

Depends on entry: Z1 - Z8

The function keys have the following special meaning during the selection procedure!

Key arrangement on the ZIMO MX32:

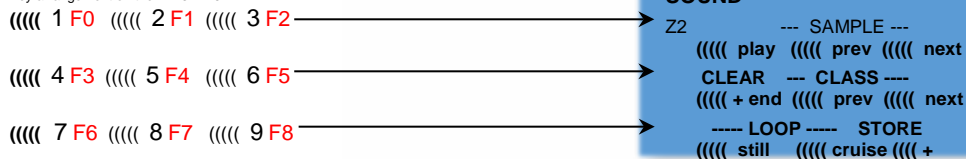

The meaning and action of the function keys is the same as for function sounds (see above):

- F0** = play: Playback
- F1, F2** = prev, next: playback of previous or next sound sample and so on...

however,...

**F6** – standstill: If F6 is active when ending the allocation procedure: the selected sound sample is played as random sound at standstill (default).

**F7** = cruise: If F7 is active when ending the allocation procedure: the selected sound sample is played as random sound when the locomotive is moving. (Default: no)

The allocation procedure for random sound is the same as for function sound!

**Allocation of sound samples to switch inputs S1, S2 and S3:**

There are 3 switch inputs available, of which two ("1" & "2") are freely available to the user while one ("3") is usually reserved for a cam sensor input; which can also be used for other inputs if not used for a cam sensor (i.e. the virtual cam sensor is used instead). These inputs can accept reed switches, optical or hall-effect sensors and similar; see chapter 8 of the manual for small decoders: "Connecting speaker, cam sensor".

A sound sample can be allocated to each switch input, from the pool of stored samples in the decoder; playback times can be set with the help of CVs #341, #342 and #343, see CV table.

The switch input **allocation procedure** is initiated with the operations mode Pseudo-Programming

- CV #300 = 111** for switch input S1
- CV #300 = 112** for switch input S2
- CV #300 = 113** for switch input S3

etc.

Depends on entry: S1 - S8

The function keys have the following special meaning during the selection procedure!

Key arrangement on the ZIMO MX32:

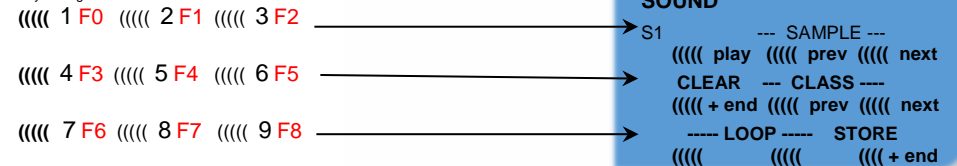

The meaning and action of the function keys is the same as for function sounds (see above):

- F0** = play: Playback
- F1, F2** = prev, next: playback of previous or next sound sample and so on...



## 5.2 The test run for determining the motor's basic load SW version 5.00 and higher

The following procedure enables the (subsequent) adjustment of driving sound to engine load (i.e. inclines, pulling weight...), such as steam chuffs (volume and sound) with the CVs #275, #276...

Technical background:

The load-dependent sound is based on EMF (Electro Motive Force) measurements inside the decoder, which is primarily used for keeping the motor speed constant during load changes. Before the decoder can produce the correct sound for the respective driving conditions it has to know first what these measurements are at normal "no-load" cruising speed (smooth rolling of the engine or train on straight and level track). This "basic load" of an engine or train is often considerably higher on model trains than on the real railroad, which is due to gearbox losses, power pick-ups etc. Deviations from this "basic load" will then be interpreted as inclines or declines, which triggers appropriately modified chuff sounds.

Initiated with pseudo programming **CV #302 = 75**

**ATTENTION:** the engine (or train) is **driven automatically** in forward direction for which unoccupied track must be available of **at least 5 meters (15 feet)**, with absolutely no inclines or declines and without any (tight) curves.

an automated test run is performed to record the "basic load" factor in forward direction;

By **CV #302 = 76**

an automated recording run is performed in reverse direction, for locomotives that have different "basic loads" in this direction (otherwise, the basic load in reverse is considered identical to forward).

The measured results are stored in **CVs #777 and #778** (slow/fast PWM values, forward) and **#779 and #780** (PWM values in reverse direction); these CVs can be read out and used as needed for other

**NOTE:** A "heavy" train (a train with higher rolling resistance due to power pickups of lighted coaches for example) may have a different "basic load" than an engine with nothing on the hook. A separate recording run may be required for such situations in order to obtain the best load dependent sound.

er vehicles, or used as base for further tests.

In case the test run is started in SERV PROG, it is important that immediately after the CV command in CV #302 the SERV PROG is left (with ZIMO controllers the E-key, or with the MX32/FU the E-key is pressed twice), so the motor starts. Please do not conduct the test drive on a roller test bench, because with higher speeds it can lead to losses of contact.

## 5.3 SOUND: Basic settings independent of powertrain

The CVs in the following table have the same meaning for all types of power (Steam, diesel, electric):

**NOTE:** The **default values** of individual CVs are **NOT decoder-specific**, but rather depend on the decoder's **sound project**. This means that a HARD RESET with CV #8 = 8 returns the decoder to the state defined by the sound project. The default values in the following table refer to the values defined in THIS sound project for Roco BR85.

| CV   | Denomination  | Range                   | Default        | Description   |
|------|---|-------------------------|----------------|---|
| #266 | Total volume<br>(Multiplier)                                | 0 - 255<br>= 0 - 400 %  | 64<br>= 100 %  | The default value "64" results in the (mathematically) highest possible distortion-free playback volume; but values of up to 100 may nonetheless be practical. <b>Recommended: CV #266 = 40 - 90</b>  |
| #310 | ON/OFF key for<br>Driving sound volume and<br>Random Sounds | 0 - 28,<br>255          | 1              | Function key to turn ON/OFF driving sounds (steam chuffs, boiling, blow-off, brake squeal, or diesel motor, thyristor sounds, etc.) as well as random sounds (air brake pump, coal shoveling, ...).<br>= 8: F8 key switches driving sound ON or OFF.<br>Note: this is the default key for ZIMO original sound projects; OEM projects (i.e. ROCO) often use other settings. Mostly 1 for the F1 key.<br>= 0 - 28 F0 - F28 as ON/OFF-key for driving noise.<br>= 255: engine and random sounds are always ON. |
| #311 | ON/OFF key for<br>function sounds                           | 0 - 28                  | 0              | Function key assigned as ON/OFF key of function sounds (i.e. F2 - whistle, F6 - bell etc.).<br>= 0: <b>does not mean</b> that F0 is assigned for this task but rather that the function sounds are always active.<br>= if the same value is entered here as in CV #310, the key defined in #310 turns all sound ON/OFF.<br>= 1 - 28: Separate ON/OFF key for function sound.  |
| #312 | Blow-off key  | 0 - 28                  | 13             | See chapter 5.4 SOUND: Steam engine → sound basic configuration", (does not belong in this chapter, despite the correct number sequence)  |
| #313 | "Mute key"<br>fade in/out time<br>key                       | 0 - 28<br>101 - 128     | 114            | This CV assigns a function key with which the driving sounds can be faded in and out, i.e. when the train disappears behind scenery. In many sound projects CV #313 = CV #310, i.e. the same value in both CVs, therefore all sounds are faded in/out.<br>= 0: No mute key or mute function.<br>= 1 - 28: Corresponding function key F1 - F28.<br>= 101 - 128: Assigned function key with inverted action.  |
| #314 | Mute -<br>fade in/out time                                  | 0 - 255<br>= 0 - 25 sec | 0              | Time in tenths of a second for sound fading in/out when mute button is pressed. Total range is 25 seconds.<br>= 0 (to 10): Minimum 1 sec<br>= 11 - 255: longer "mute"-processes   |
| #376 | Driving sound<br>Volume -<br>(Multiplier)                   | 0 - 255<br>= 0 - 100 %  | 255<br>= 100 % | To reduce the driving sound volume (e.g. Diesel motor with related sounds such as turbo charger) compared to the function sounds.   |



| CV   | Denomination  | Range                | Default | Description   |
|------|---|----------------------|---------|---|
| #287 | Threshold for brake squeal  | 0 - 255              | 50      | The brake squeal should start when the speed drops below a specific speed step. It will be automatically stopped at speed 0 (based on back-EMF results).  |
| #288 | Brake squeal Minimum drive time   | 0 - 255 = 0 - 25 sec | 50      | The braking squeal is to be suppressed when an engine is driven for a short time only, which is usually a shunting run and often without any cars (it is mostly the cars that are squealing not the loco itself!).<br><b>NOTE:</b> Brake squeal sounds can also be assigned to a function key (see allocation procedure CV #300 = ...), with which the brake squeal can be started or stopped manually! (SW version 5.00 and higher)  |
| #307 | Cornering squeals or Reed configuration   |                      |         | Bit0 - switching input 1 activates cornering squeal<br>Bit1 - switching input 2 activates braking squeal<br>Bit2 - switching input 3 activates braking squeal<br>Bit3 - switching input 4 activates braking squeal<br>Bit7 - 0 = key defined in CV #308 suppresses cornering squeal of Reed inputs if this key is ON<br>1 = key defined in CV #308 activates cornering squeal independent of Reed inputs  |
| #308 | cornering squeal key  | 0-28                 | 25      | 0: No key defined. Reed inputs always active.<br>1-28 = key F1 to F28.  |
| #133 | Use of FO4 FO4 as normal function output or FO4 as output for steam exhaust fan smoke generator in steam locos and IN (reed) pins Configuration and MS440: FO9 to pin IN4 |                      | 0       | = 0: FA4 used as normal function output, i.e. controllable by a function key,<br>= 1: FA4 for smoke fan controlled by "simulated" axis detector or by "real" axis detector. See CVs #267, #268!<br><b>NOTE:</b> The operation mode of a fan is also determined by the sound project.<br><b>NOTE:</b> Large scale decoders have special outputs and setting options for fans!<br>Bit 4 – inverts the polarity of Reed input 1<br>Bit 3 – inverts the polarity of Reed input 2<br>Bit 2 – inverts the polarity of Reed input 3<br>Bit 5 – inverts the polarity of Reed input 4<br>Bit 6 - (only types MS440) Pin IN4 becomes output FO9 |
| #395 | Maximum volume for volume increase key  | 0 - 255              | 64      | Configuration range for volume with the help of the louder key according to CV #397; can also be higher than the basic configuration in CV #266.  |
| #396 | volume decrease key   | 0 - 29               | 0       | 0 = No key defined.<br>1-28 = key F1 to F28 29 = F0-key   |
| #397 | Volume increase key   | 0 - 29               | 0       | 0 = No key defined.<br>1-28 = key F1 to F28 29 = F0-key   |
| #346 | Conditions for switching between collections, as per CV #345  |                      |         | Those CVs can be found in chapter "Diesel and electro locos → ..."<br><br>They are valid for all types of drives, but are mainly important for diesel locos.  |
| #835 | Further switching keys  |                      |         |   |
| #347 | Switch key for driving and sound performance when driving solo  |                      |         |   |
| #348 | Measures to be taken when switching to solo drive (with key selected in CV #347)  |                      |         |   |

SW version 4.00 (sound projects for diesel and electro locos) (not yet implemented in SW-version 4.00: Diesel with manual transmission)

Background sounds - Volume adjustments:

|      |                             |         |   |   |
|------|-----------------------------|---------|---|---|
| #574 | "Simmering"                 | 0 - 255 | 0 | Volume driving sound "simmering"          |
| #576 | Sound "changing directions" | 0 - 255 | 0 | Volume driving sound for e.g. Johnson Bar |
| #578 | "Brake squeal"              | 0 - 255 | 0 | Braking squeal volume                     |
| #580 | Thyristor sound             | 0 - 255 | 0 | Thyristor sound volume (ELECTRIC engine)  |
| #582 | "Starting whistle"          | 0 - 255 | 0 | Volume Starting whistle (STEAM/DIESEL)    |
| #584 | Blow-off                    | 0 - 255 | 0 | Blow-off volume (STEAM engine)            |
| #586 | Electric motor              | 0 - 255 | 0 | Electric motor volume (ELECTRIC engine)   |
|      | Planned for SW version 5.00 | 0 - 255 | 0 | Driving sounds                            |
| #590 | Electric switch gear sound  | 0 - 255 | 0 | Switch gear volume (ELECTRIC engine)      |
| #592 | "Second thyristor"          | 0 - 255 | 0 | Second thyristor (ELECTRIC)               |
|      | Planned for SW version 5.00 | 0 - 255 | 0 | Panto up (ELECTRIC)                       |
|      | Planned for SW version 5.00 | 0 - 255 | 0 | Panto down (ELECTRIC)                     |
|      | Planned for SW version 5.00 | 0 - 255 | 0 | Panto stop (ELECTRIC)                     |
| #600 | Turbo                       | 0 - 255 | 0 | Turbocharger volume (DIESEL engine)       |
| #602 | Dynamic brakes              | 0 - 255 | 0 | Volume "dynamic brake"                    |
| #604 | "Cornering squeal"          | 0 - 255 | 0 | Volume "cornering squeal"                 |

**NOTE:** The CVs before the names (#573, #575, #577, etc.) contain information to the corresponding sound sample (sound number, loop parameters), which can be modified, if necessary, usually by the CV #300 procedure.

Function sounds - Volume adjustments:

|                                     |   |                        |   |   |
|-------------------------------------|---|------------------------|---|---|
| #571                                | Function sound F0   | 0 - 255 = 100, 1-100 % | 0 | Sound volume operated with function key F0<br>= 0: full volume, original sound sample volume (same as 255)<br>= 1 - 254: reduced volume 1 – 99.5 %<br>= 255: full volume                    |
| #514<br>#517<br>#520<br>#523<br>... | Function sound F1<br>Function sound F2<br>Function sound F3<br>Function sound F4<br>... | 0 - 255                | 0 | Sound volume operated with function key F1<br>Sound volume operated with function key F2<br>Sound volume operated with function key F3<br>Sound volume operated with function key F4<br>... |
| #565<br>#568                        | Function sound F18<br>Function sound F19  |                        |   | Sound volume operated with function key F18<br>Sound volume operated with function key F19  |
| #674<br>...<br>#698                 | Function sound F20<br>...<br>Function sound F28   | 0 - 255                | 0 | Sound volume operated with function key F20<br>...<br>Sound volume operated with function key F28   |

**NOTE:** The CVs between the above (#570, #572, #513, #515, #516, #518 etc.) contain information to the corresponding sound samples (sample numbers, loop parameters etc.), which can also be modified if needed, usually with the CV #300 procedures.



**Switch input sounds** - Volume adjustments:

Planned in SW version 5.00 and later!

|      |                       |                           |   |   |
|------|-----------------------|---------------------------|---|---|
| #739 | Switch input sound S1 | 0 - 255<br>= 100, 1-100 % | 0 | Volume setting for the sound activated with switch input S1<br>= 0: full volume, original sound sample volume (same as 255)<br>= 1 - 254: reduced volume 1 – 99.5 %<br>= 255: full volume |
| #741 | Switch input sound S2 | 0 - 255                   | 0 | Volume setting for the sound activated with switch input S2   |
| #743 | Switch input sound S3 | 0 - 255                   | 0 | Volume setting for the sound activated with switch input S3   |
| #671 | Switch input sound S4 | 0 - 255                   | 0 | Number of sound sample for input S4   |
| #672 | Switch input sound S4 | 0 - 255                   | 0 | Volume setting for the sound activated with switch input S4   |

**NOTE:** The CV immediately ahead of the CVs listed (#740, #742) contains the sound sample numbers to be played.

**Random sounds** - Volume adjustments:

|      |                 |  |   |   |
|------|-----------------|--|---|---|
| #745 | Random Sound Z1 |  | 0 | Volume setting for sound activated by random generator Z1 |
| #748 | Random Sound Z2 |  | 0 | Volume setting for sound activated by random generator Z2 |
| #751 | Random Sound Z3 |  | 0 | Volume setting for sound activated by random generator Z3 |
| #754 | Random Sound Z4 |  | 0 | Volume setting for sound activated by random generator Z4 |
| #757 | Random Sound Z5 |  | 0 | Volume setting for sound activated by random generator Z5 |
| #760 | Random Sound Z6 |  | 0 | Volume setting for sound activated by random generator Z6 |
| #763 | Random Sound Z7 |  | 0 | Volume setting for sound activated by random generator Z7 |
| #766 | Random Sound Z8 |  | 0 | Volume setting for sound activated by random generator Z8 |

**NOTE:** The CV immediately ahead of the CVs listed (#744, #747 etc.) contain the sound sample numbers to be played. Possibility to adjust via ZCS (ZIMO CV Setting) tool.

**Connection between sounds** and function output:

("Connection" means: in the time another sound is played back, a special function output shall be activated; typical use: automatic flickering of fire chamber during coal shoveling).

|             |                    |  |   |  |
|-------------|--------------------|--|---|--|
| #726        | Connection 1 sound |  | 0 | Sound number for connection 1 (usually defined by sound project and should not be changed if possible). Within the documentation of (most of the) sound projects sound numbers are listed. |
| #727        | Connection 1 FO    |  | 0 | Function output to connection 1 which shall be activated - if the sound is played back. 1 = FO0f, 2 = FO0r, 3 = FO1, ...   |
| #728        | Connection 2 sound |  | 0 | Sound number to connection 2   |
| #729        | Connection 2 FO    |  | 0 | Function output to connection 2:<br>1 = FO0f, 2 = FO0r, 3 = FO1, ...   |
| #730 - #735 | ...                |  | 0 | ...  |
| #736        | Connection 6 sound |  | 0 | Soundnumber to connection 6.   |
| #737        | Connection 6 FO    |  | 0 | Function output to connection 6:<br>1 = FO0f, 2 = FO0r, 3 = FO1, ...   |

**5.4 SOUND: Steam engine → sound basic configuration**

| CV   | Denomination  | Range                         | Default |    | Description  |
|------|---|-------------------------------|---------|----|--|
| #266 | Total volume  | 0 - 255                       | 64      |    | See chapter 5.3 SOUND: Basic settings independent of powertrain  |
| #267 | Chuff sound frequency according to "virtual Cam sensor"<br><br>also see CV #354 in this table (Steam chuff frequency at speed step 5)           | 0 - 255                       | 63      |    | CV #267 is only active if <b>CV #268 = 0</b> : Chuff beats follow the "virtual cam sensor"; an actual cam sensor is not needed in this case. The basic configuration "70" results in about 4 to 6 to 8 chuffs per rotation, depending on the selected chuff-set. Because it also depends in large part on the motor and gearbox used, an individual adjustment is necessary in most cases in order to achieve the exact chuff frequency; therefore, CV #267 is used: The lower the value the higher the chuff frequency and vice versa. The setting should be performed at low speed (around speed step 20-25, not 5). By means of CV #393 bit 6 = 1 the chuff interval of CV #267 can be extended 4 times.  |
| #268 | Switch to real cam sensor and<br>Number of spikes of the cam sensor for chuff beat<br>and<br>Special functions "simple articulated" steam locos | 0 - 63<br><br>and<br>128, 192 | 1       | 0  | = 0: "Virtual" cam sensor is active (to be adjusted with CV #267, see above).<br>= 1: = 1: Real cam sensor (connected to „In2" resp. "In3" of the decoder) is active, each negative spike results in a chuff<br>= 2, 3, 4 ... real cam sensor, several triggers in sequence (2, 3, ... 63) result in one chuff beat.<br>= 128 (bit 7=1 with "virtual" cam sensor): second driver is a bit slower; only meaningful if a second sound sample is available in the sound project.<br>= 192 (bits 6 and 7 = 1): When no separate sound sample is available for the second driver, the same sample is played back for the second driver, only a bit slower.<br>Bit 7 = 1: with real cam sensor, see values above<br>Cam sensor for driver 1 at IN3 (as always),<br>Cam sensor for driver 2 at IN2, (only possible if decoder has two inputs) |
| #269 | Accentuated lead-chuff  | 0 - 255                       | 10      | 0  | A typical sound signature of a passing steam engine is that one chuff out of a group of 4 or 6 chuffs is louder in volume than the rest; this effect is already part of the chuff set but can be further amplified with the help of CV #269.   |
| #271 | Fast driving overlapping effect at high speed-effects   | 0 - 255 (Useful up to @ 30)   | 1       | 16 | The individual steam chuffs of a real engine overlap each other at high speed. Because the frequency of the chuffs increases but will not shorten to the same extend, they will eventually blend in to a weakly modulated swoosh. This is not always desired in model railroading because it does not sound that attractive, hence CV #271, with which an adjustment is possible to have the chuff beats accentuated at high speed or rather fade away.  |
| #272 | Blow-off-duration   | 0 - 255 =                     | 80      |    | Opening the cylinder valves on a prototype steam engine for the purpose of water drainage is entirely up to the engineer. An automated draining at   |



| CV   | Denomination   | Range                      | Default |   | Description  |
|------|--|----------------------------|---------|---|--|
|      | also see CV #312 in this table (Blow off Key)                              | 0 - 25 sec                 |         |   | start-up is more suitable in model railroading; CV #272 defines how long after start-up the blow-off sound should play.<br>Value in CV #272 = time in tenths of a second!<br>Note: If the blow-off sound is also allocated to a function key (as delivered on F4, see CV #312), the automated blow-off sound can be shortened or extended with the relevant function key. Automated blow-off and function key blow-off are inevitably the same (as per selection/allocation).<br>= 0: no blow-off sound playback   |
| #273 | Blow-off-Start-up delay  | 0 - 255<br>=<br>0 - 25 sec | 1       | 0 | Opening the cylinder valves and with it the related blow-off sound on a real steam engine starts most often before the engine even starts to move. This can be imitated with CV #273 by automatically delaying the start of the locomotive.<br>This effect is cancelled when a shunting function with momentum deactivation is being activated (see allocation of F3 or F4 in CV #124!)<br>= 0: no delayed start<br>= 1: Special setting blow-off by controller; no delayed start, however, lowest speed step (lowest slider position > 0, only for 128 speed steps) means "do not drive yet, but blow off!")<br>= 2 ... Start-up delay in tenths of seconds: Recommendation: no values > 20 (> 2 sec) |
| #274 | Blow-off-Standstill and Starting whistle Standstill                        | 0 - 255<br>=<br>0 - 25 sec | 30      |   | Constant opening and closing of the cylinder valves in real shunting operations, that often requires many short trips with associated idle times, is usually omitted. CV #274 causes the blow-off sound to be suppressed if the engine wasn't standing still for the time defined here.<br>Value in CV #274 = time in tenth of a second!<br>The same stop-time is also used for the start-up whistle!  |
| #312 | Blow-off key   | 0 - 28                     | -       |   | Defines function key which activates blow-off noise; e.g. for shunting with "open valves".   |
| #354 | Chuff beat frequency at speed step 5<br><br>also see CV #267 in this table | 1 - 255                    | 11      |   | CV #354 works only if used with CV #267!<br>CV #354 compensates for the non-linear speed measurements of the "virtual cam sensor":<br>While the adjustment of CV #267 is done in the vicinity of speed step 20-30, a correction for speed step 5 can be performed with CV #354 (extremely slow).<br>= 0: no effect<br>= 1 - 127: Steam chuffs at speed step = 1 (and extremely slow speed) more common than CV #267<br>= 255 - 128: less chuff beats.  |
| #154 | Various special bits   |                            | 16      |   | Bit 1 = 1: DIESEL, ELECTRO Drive off immediate-  |

| CV   | Denomination  | Range | Default |   | Description   |
|------|---|-------|---------|---|---|
|      | planned in SW version 5.00 and higher   |       |         |   | ly even if playback of idle sound has not yet finished.<br>Bit 2 = 1: DIESEL, ELECTRO After short stops, wait for idle sound before driving off.<br>Bit 4 = 1: STEAM: Two stage compressor (Z1 for fast refill after coming to a stop, Z2 for slow pressure loss compensation during longer stops).<br>Bit 7 = 1: Delay start until playback of start-up whistle has finished.<br>Other Bits: OEM special features (Loco with pantograph, etc.)   |
| #158 | Various special bits<br>Bits 1, 3, 5, 6, 7 (only DIESEL & ELECTRO);<br>SW version 5.00 and higher |       | -       | 0 | Bit 1 = 1: Diesel mechanical: RPM is not raised when braking (see CV #364).<br>Bit 3 = 1: (DIESEL) Sample for standstill is faded out when driving-off "early".<br>Bit 4 = 1: Steam chuff frequency increases slower at high speed (non-proportional)<br>Bit 5 = 1: (DIESEL) Braking (even by one speed step) causes the motor and turbo sounds to decrease by on sound step.<br>Bit 6 = 1: (ELECTRO) Thyristor sound may be louder when braking.<br>Bit 7 = 1: (ELECTRIC) Switchgear sparks on FO7.  |
| #393 | ZIMO special configuration bits „5“   |       |         |   | Bit 0 = 1: Activates ditchlight when bell plays<br>Bit 1 = 1: Activates ditchlight when horn plays<br>Bit 2 = 0: Always start with the 1st sample of the high-speed gear shift<br>= 1: Play one sample after the other<br>Bit 3 = 0: When shifting up, play beginning and end part (Only the middle part when shifting down).<br>= 1: Also when shifting up, skip start and end part (as with shifting down).<br>Bit 4 = 1: Do not raise thyristor2 pitch.<br>Bit 5 = 1: Switch SUSI to reed inputs<br>Bit 6 = 1: 4x extend chuff beat interval |



## 5.5 SOUND: Steam locomotive → Load and acceleration dependency

The load dependency of the sound is based on the current engine load and the accelera-

**NOTE:** The CVs in this chapter affect the sound volume according to load (that is, by how much the volume should increase at higher loads or decrease at lesser loads, all the way down to mute if necessary). A possible exchange of sound samples at load increase or decrease is however a matter of the sound project. There are a few exceptions from this rule, though...

The **default values** listed for the individual CVs are typical guidelines only, as the real values are defined by the loaded **sound-project**; i.e. a HARD RESET with CV #8 = 8 reinstalls the values defined by the sound project.

tion/deceleration.

| CV   | Denomination  | Range   | Default |                 | Description  |
|------|---|---------|---------|-----------------|--|
| #275 | Volume chuff volume at high speed without load                                    | 0 - 255 | 220     |                 | With this CV the chuff volume can be adjusted for low speed and "basic load" (same conditions as during the "calibration run").<br><b>"Calibration run" SW version 5.00 and higher</b><br>Here, the engine is driven by about 1/10 of its full speed, adhering to the exact speed is however not important.<br>During this adjustment CV #277 is to be left at "0" (default), so that the setting for "no-load driving" is not influenced by load factors. |
| #276 | Volume - at high speed without load   | 0 - 255 | 220     |                 | Like CV #275 (see above) but for driving fast. Set the speed regulator to maximum during this set-up.  |
| #277 | Dependency of Volume - chuff volume of current load in SW version 5.00 and higher | 0 - 255 | 10      | 0 = no reaction | When deviating from the basic load (as determined by the "Automated recording of the motor's "basic load" factor", see above), the chuff beat volume should be increasing (on inclines) or decreasing on declines (even muted).<br>CV #277 defines the degree of change, which must be set to the proper value by trial.   |
| #278 | Load changing threshold in SW version 5.00 and higher                             | 0 - 255 | 10      | 0               | With this CV, a change in volume to small load changes can be suppressed (i.e. in curves) in order to prevent chaotic sound impressions. Suitable settings can only be determined by trial.  |
| #279 | Load changing delay in SW version 5.00 and higher                                 | 0 - 255 | 1       | 0               | This CV determines how quick the sound reacts to load changes, whereas the factor is not just time but rather "load-change dependent time" (= the bigger the change the faster the effect). This CV is also used to suppress chaotic sound changes. Suitable settings can only be determined by trial.   |

|      |  |                                |     |  |   |
|------|--|--------------------------------|-----|--|---|
| #283 | Driving noise- (Steam chuffs) Volume - for full acceleration sound | 0 - 255                        | 255 |  | The volume of steam chuffs at maximum acceleration is set with CV #283 (default: 255 = full volume).<br>If CV #281 = 1 (acceleration threshold set to 1 speed step), the volume defined here is applied with each speed increase, even if it's just 1 step.   |
| #284 | Deceleration threshold for reduced volume during deceleration      | 0 - 255 (Internal Speed steps) | 1   |  | Steam chuffs should be played back at less volume (or muted) signifying the reduced power requirement during deceleration. The sound reduction logic is analog to a reversed acceleration (per CV #281 to #283).<br>= 1: Reduces sound to a minimum (as per CV #286) when speed is reduced by just 1 step.<br>= 2, 3 ... sound reduced to minimum after lowering speed by this number of steps. |
| #285 | Time needed for the Volume reduction at deceleration               | 0 - 255 = 0 - 25 sec           | 30  |  | After the speed has been reduced, the sound should remain quieter for a specific time (analog to the acceleration case).<br>Value in CV #285 = time in tenth of a second!   |
| #286 | Volume - of reduced driving noise- at deceleration                 | 0 - 255                        | 20  |  | CV #286 is used to define the chuff volume during deceleration (Default: 20 = pretty quiet but not muted).<br>If CV #284 = 1 (deceleration threshold set to 1 speed step), the volume defined here is applied with every reduction in speed (even if decreased by just 1 step).   |



## 5.6 Diesel and Electric engines → Diesel motor, Turbocharger Thyristor, Electric motor, Switchgear sound

Diesel and Electric engines have certain commonalities and are therefore described in the same chapter: Diesel-electric propulsion systems have sound components (sound sequences) from both areas. On the other hand, the separation of "Basic settings" and "Load dependence" (as with the steam engines in the previous chapters) is not practical.

| CV   | Denomination   | Value-Range | INC step | De-fault | Description   |
|------|--|-------------|----------|----------|---|
| #266 | Total volume   | 0 - 255     | 5        | 64       | See chapter 5.3 SOUND: Basic settings independent of powertrain   |
| #280 | Diesel engine - Load dependency<br><br>in SW version 5.00 and higher   | 0 - 255     | 10       |          | With this setting, the diesel motor's reaction to the load (defined by PWM and speed step).<br><b>NOTE:</b> the sound of the diesel motor practically always depends on acceleration and speed.<br>Diesel-hydraulic loco - higher and lower PWM and performance steps,<br>Diesel-electric loco - driving/idle loco with switchgear - steps.<br>= 0: no influence Motor PWM according to speed<br>= 1 to 255: increasing to maximum influence<br><b>NOTE:</b> It is recommended, first to perform the <b>automated test run</b> with CV #302 = 75 first (see chapter 5.2).                                       |
| #154 | Various special bits   |             | -        |          | Bit 1 = 1: (DIESEL) Drive off immediately even if playback of idle sound has not yet finished.<br>Bit 2 = 1: DIESEL, ELECTRO After short stops, wait for idle sound before driving off.<br>Bit 4 = 1, bit 7 = 1: see STEAM.   |
| #158 | Bit 1 SW version 5.00 and higher (only diesel mechanical)<br><br>Various special bits (mostly in connection with functions defined in various other CVs) |             |          |          | Bit 1 = 1: Diesel mechanical: RPM is not raised when braking (see CV #364).<br>Bit 2 = 0: RailCom speed feedback (km/h) feedback in "old" format (for MX31ZL, RailCom ID 4)<br>= 1: RailCom speed feedback (km/h) Normal feedback (RailCom ID 7)<br>Bit 3 = 1: "Looped" driving sounds (i.e. idle sound) will be faded out when switching to a different speed step in order to shorten the sounds.<br>Bit 4 = 1: Steam chuff frequency increases slower at high speed (non-proportional)<br>Bit 5 = 1: Braking (even by one speed step) causes the motor and turbo charger sound to pitch down one sound step. |

|      |   |                         |   |   |   |
|------|---|-------------------------|---|---|---|
| #344 | Run time of motor sounds (Cooling fan, etc.) after stops  | 0 - 255<br>= 0 - 25 sec | - |   | After the engine comes to a stop, some accessories are supposed to remain operating (e.g. cooling fans) and automatically stop after the time defined here, provided the engine didn't start up again.<br>= 0: Will not run after stop<br>= 1 - 255: Runs for another 1 to 25 seconds.  |
| #345 | Switch key to next sound variation within a sound collection for different operating modes of a locomotive or between the sounds of a multi-system engine | 1 - 28                  |   |   | Defines a function key (F1 - F28) which switches between two sound types that is, between the selected sound in CV #265 and the next one in the list. For example:<br>- Switch between two modes of operation (light train / heavy train) or<br>- Switch between electric and diesel propulsion of a multi-system engine; typical case:<br>Sound project for RhB Gem.   |
| #346 | Conditions for switching between collections, as per CV #345  | 0, 1, 2                 |   | 0 | Bit 0 = 1: Switches also at stand-still,<br>Bit 1 = 1: Switches also while cruising (bits for standstill and cruising possible at the same time)<br>Bit 6 = 1: Transition sets in diesel projects, which are played back when switching from one set to another.  |
| #835 | Further switching keys  | 0 - 32                  |   |   | Extension to CV #345. Here the number of consecutive keys can be defined, which then switch to auf Set2, Set3, Set4, ..... Then first key is still defined in CV #345.  |
| #347 | Switch key to switch key for driving and sound performance when driving solo  | 0 - 28                  |   |   | = 0: No key, no switch possible.<br>= 1 - 28: One of these function keys (F1 - F28) acts as the switch-over key for driving a heavy train or a single locomotive. Parameters are selected with CV #348.   |
| #348 | Selection of measures to be taken when switching to solo drive (with key selected in CV #347)   | 0 - 31                  |   |   | When driving solo (function key as per CV #347 is ON), ...<br>Bit 0 = 1: ... Diesel sound (sound steps) shall rise unlimitedly at acceleration (otherwise limited by CV #389 dependent of speed step).<br>Bit 1 = 1: ... acceleration and deceleration times should be reduced according to CV #3 / #4 but consider the range of reduction defined in CV #390.<br>Bit 2 = 1: ...driving at low-speed ranges with stationary noise possible, whereby the highest speed step with stationary noise is defined in CV #391.<br>Bit 3 = 1: 2nd smoke fan and heater deactivated with loco driving key (two-motor diesel loco only drives with one).<br>2nd smoke fan and heating deactivated on the higher output each if this key is ON<br>Bit 4 = 1: Brake squeal is suppressed with loco driving key. |
| #387 | Acceleration influence on diesel sound steps  | 0 - 255                 |   | 0 | In addition to the selected speed step (as defined in the ZSP flow diagram), actual changes in speed (acceleration, deceleration) should also have an   |

|      |  |         |   |  |
|------|--|---------|---|--|
|      |  |         |   | influence on the sound due to the associated increase or decrease in load.<br>= 0: No influence (sound depends on speed step only)<br>= 64: experience has shown this to be a practical value<br>= 255: maximum acceleration response (Highest sound step during acceleration)   |
| #388 | Deceleration influence<br>On diesel sound steps  | 0 - 255 | 0 | Same as CV #387 but used during decelerations.<br>= 0: No influence (sound depends on speed step only)<br>= 64: experience has shown this to be a practical value<br>= 255: maximum deceleration response  |
| #389 | Limited acceleration influence on diesel sound steps   | 0 - 255 | 0 | This CV determines how far the sound step may deviate during acceleration from the simple speed step dependence (= difference between target speed from the controller and actual speed).<br>= 0: No deviation; motor sounds according to schedule, sound does not depend on acceleration.<br>= 1 - 254: Dependence increases with value.<br>= 255: fully dependent on target speed. |
| #390 | Momentum reduction when driving solo (engine only)   | 0 - 255 | 0 | When switching to solo driving with key defined in CV #347 the momentum reduction is activated (with CV #348, Bit 1):<br>= 0 or 255: No reduction<br>= 128: Reduction to 50 %<br>= 64: Reduction to 25 %<br>= 1: virtually cancels all momentum.   |
| #391 | Driving with idle sound, when driving solo   | 0 - 255 | 0 | The diesel motor sound should remain at idle when driving solo (with function key defined in CV #347), until the speed step defined in CV #391 is reached.   |
| #836 | Motor Start Sound  | Bit 0   | 0 | Bit 0 = 1: Loco shall not start driving before Start Sound is fully played.  |
| #378 | Statistical probability Of switchgear sparks during acceleration<br><i>In SW version 5.00 and higher</i> | 0 - 255 | 0 | Likelihood for sparks (as per CV #158 Bit 7 for FO7 or #394 for FO6) when accelerating<br>= 0: always<br>= 1: very rarely<br>= 255: very often (almost always)   |
| #379 | Statistical probability of switchgear sparks during deceleration<br><i>In SW version 5.00 and higher</i> | 0 - 255 | 0 | Likelihood for sparks when decelerating (as per CV #158 Bit 7 for FO7 or #394 for FO6)<br>= 0: always<br>= 1: very rarely<br>= 255: very often (almost always)   |
| #364 | Diesel engine with Switchgear<br>Speed drop during upshifts<br><i>In SW version 5.00 and higher</i>      |         | 0 | This special CV applies only to diesel-mechanical engines and defines the typical drop in speed when shifting up.<br>See sound projects (i.e. VT 61)   |
| #365 | Diesel engine with   |         | 0 | This special CV applies only to diesel-mechanical  |

|      |   |         |     |   |
|------|---|---------|-----|---|
|      | Switchgear<br>Upshift rpm<br><i>In SW version 5.00 and higher</i>                       |         |     | engines and defines the highest rpm before shifting up.<br>See sound projects (i.e. VT 61)  |
| #366 | Turbocharger<br>Maximum volume  | 0 - 255 | 48  |   |
| #367 | Minimum load for turbo before DIESEL engines<br>Turbo rpm dependency on speed           | 0 - 255 | 150 | Turbo playback frequency depending on engine speed.   |
| #368 | Turbocharger<br>Turbo rpm dependency on acceleration for DIESEL engines<br>Acceleration | 0 - 255 | 100 | Playback frequency depends on the difference of set speed to actual speed (= acceleration).   |
| #369 | Turbocharger<br>Minimum load  | 0 - 255 | 30  | Audibility threshold for turbochargers; the load is derived from CV #367 and #368.  |
| #370 | Turbocharger<br>Frequency increase  | 0 - 255 | 25  | Speed of frequency-increase of the turbocharger.  |
| #371 | Turbocharger<br>Frequency decrease  | 0 - 255 | 15  | Speed of frequency-decrease of the turbocharger.  |
| #289 | Thyristor<br>Step-effect  | 0 - 255 |     | = 1 - 255: Effect of pitch  |
| #290 | Thyristor sound pitch:<br>"slow" pitch increase   | 0 - 255 | 50  | Sound pitch for speed defined in CV #292.   |
| #291 | Thyristor sound pitch:<br>Maximum pitch   | 0 - 255 |     | Sound pitch at top speed.   |
| #292 | Thyristor sound pitch:<br>slow speed  | 0 - 255 |     | Speed for sound pitch per CV #290.  |
| #838 | Thyristors Maximum speed  | 0 - 255 | 255 | Definition of the "maximum" speed level (1 - 255) for which pitch applies according to CV #291.   |
| #293 | Thyristor sound pitch:<br>Steady volume   | 0 - 255 | 100 | Thyristor sound volume at steady speed (no acceleration or deceleration in progress).   |
| #294 | Thyristor sound pitch:<br>Volume at acceleration  | 0 - 255 | 200 | Volume during acceleration  |
| #295 | Thyristor sound pitch:<br>Volume at deceleration  | 0 - 255 | 100 | Volume during heavier decelerations (braking)   |
| #357 | Thyristor sound pitch:<br>Lowering volume at higher speed                               | 0 - 255 | 0   | Internal speed step at which the thyristor sound volume should be reduced. The volume stays at this reduced level while braking.<br>By changing CV #158 Bit 6 = 1, the volume will be raised while braking, nonetheless.                                |
| #358 | Thyristor sound pitch:<br>Course of Lowering volume at higher speed                     | 0 - 255 | 0   | Defines a curve as to how the thyristor sound should be lowered at the speed step defined in CV #357.<br>= 0: no reduction.<br>= 10: reduced by about 3 % per speed step.<br>= 255: aborts the sound when the speed step defined in CV #357 is reached. |





|      |  |         |  |    |  |
|------|--|---------|--|----|--|
| #362 | Thyristor sound pitch:<br>Switching threshold to second sound:                                       | 0 - 255 |  | 0  | Defines a speed step at which a second thyristor sound for higher speeds is played back; this was introduced for the sound project "ICN" (Roco OEM sound)<br>= 0: no second thyristor sound.   |
| #393 | ZIMO Config 5  | Bit 4   |  | 0  | = 1: Thyristor 2 do not elevate pitch  |
| #394 | ZIMO Config 4  | Bit 7   |  | 0  | = 1: Thyristor sound starts playing before start-up  |
| #296 | Electric motor Volume  | 0 - 255 |  | 0  | Motor sound volume.  |
| #297 | Electric motor Minimum load  | 0 - 255 |  | 0  | Internal speed step at which the motor sound becomes audible; at this speed step is starts at a low volume and reaches maximum volume as per CV #296 at the speed step define in CV #298.  |
| #298 | Electric motor volume - Speed dependency   | 0 - 255 |  | 0  | Internal speed step at which the motor sound reaches the maximum volume defined in CV #296. (See ZSP manual!)  |
| #299 | Electric motor Pitch (frequency) Speed dependency  | 0 - 100 |  | 0  | The motor sound will be played back faster, corresponding to this CV with rising speed.<br>=0: Pitch (speed of play back) will not rise<br>=100: Doubling the pitch  |
| #372 | Electric motor Volume - Acceleration dependency  | 0 - 255 |  | 0  | = 0: No function<br>= 1 - 255: minimal to maximal effect   |
| #373 | Electric motor Volume - Dependent on braking   | 0 - 255 |  | 0  | = 0: No function<br>= 1 - 255: minimal to maximal effect   |
| #350 | Electric switch gear sound, locked after Starting  | 0 - 255 |  | 0  | Time in tenth of seconds (0-25 sec), the switch-gear sound shall not be played back after starting; this is useful if the first switching step is already in the sample "Stand -> F1".<br>= 0: Switchgear is played back immediately after starting. |
| #359 | Electric switch gear sound, Switch gear playback duration during speed changes                       | 0 - 255 |  | 30 | Time in tenth of a second the switch gear should be heard during speed changes (adjustable from 0 - 25 sec.).<br>Effective only if switch gear sound is part of the sound project.   |
| #360 | Electric switch gear sound, Duration of playback after stopping<br><b>SW version 5.00 and higher</b> | 0 - 255 |  | 0  | Time in tenth of a second the switch gear should be heard after the engine comes to a full stop (adjustable from 0 - 25 sec.).<br>= 0: no sound after stop.  |
| #361 | Electric switchgear Time until the next playback   | 0 - 255 |  | 20 | During rapid successions in speed changes the switchgear sound would be played back too often.<br>CV #361: Time in tenths of a second (0 - 25 sec.) defines minimum delay between multiple play-backs.   |
| #363 | Electric switch gear sound, Distribution of speed  | 0 - 255 |  | 0  | Number of shift steps to cover the whole speed range; i.e. if 10 shift steps are programmed, the switch gear sound is played back at internal  |

|      |  |         |  |   |  |
|------|--|---------|--|---|--|
|      | steps on switching steps                     |         |  |   | speed step 25, 50, 75... (a total of 10 times)<br>= 0: synonymous with 5 (5 switch steps over the whole speed range).  |
| #393 | ZIMO Config 5                                | 0 - 255 |  | 0 | Bit 0 = 1: Activates ditchlight when bell plays<br>Bit 1 = 1: Activates ditchlight when horn plays<br>Bit 2 = 0: Always start with the 1st sample of the high-speed gear shift<br>= 1: Play one sample after the other<br>Bit 3 = 0: When shifting up, play beginning and end part (Only the middle part when shifting down).<br>= 1: Also, when shifting up, skip start and end part (as with shifting down).<br>Bit 4 = 1: Do not raise thyristor2 pitch.<br>Bit 5 = 1: Switch SUSI to reed inputs<br>Bit 6 = 1: 4x extend chuff beat interval |
| #380 | Manual electric brake key key                | 1 - 28  |  | 0 | Defines a function key to manually control the sound of a "dynamic" or "electric" brake.   |
| #381 | Electric brake minimal speed step            | 0 - 255 |  | 0 | The electric brake shall only be heard between the value defend in CV #381...  |
| #382 | Electric brake maximum speed step            | 0 - 255 |  | 0 | ...and the value in CV #382  |
| #383 | Electric brake Pitch                         | 0 - 255 |  | 0 | = 0: Pitch independent of speed<br>= 1 - 255: ...depends increasingly on speed.  |
| #384 | Electric brake Deceleration threshold        | 0 - 255 |  | 0 | The number of speed steps to be reduced during deceleration before the electric brake sound is played back.  |
| #385 | Electric brake Driving on slopes             | 0 - 255 |  | 0 | = 0: no effect at "negative" load<br>= 1 - 255: Sound triggered at "negative" load.  |
| #386 | Electric brake Loop                          | 0 - 15  |  | 0 | Bit 3 = 0: Sound fades out at end of sample<br>= 1: Sound ends without fading at end<br>Bit 2 - 0: Extension of the minimal runtime of the brake sound by 0 to 7 sec, so no interruption of the brake sound occurs between the speed steps   |
| #356 | Speedlock key<br><b>SW V 5.00 and higher</b> | 0 - 28  |  | 0 | If this key is activated, the speed controller changes the driving sound, not the speed  |
| #837 | Script processes                             | Bit 0-7 |  | 0 | Bit 0-7 = 1: Deactivate scripts 1-8  |
| #843 | Script processes                             | Bit 0-7 |  | 0 | Bit 0-7 = 1: Deactivate scripts 9 - 16   |

### 5.7 Coasting and Notching

Functions are required for driving situations where the correct engine sound cannot be derived from speed, acceleration, and load only.

Primarily in diesel locomotives (but not necessarily limited to diesels), the motor's idle sound or a certain specified speed step sound is enforced by keystroke.

This method can be used for "downshifting" (often to neutral) as well as "upshifting" (i.e. elevated idle for heating). Future software versions will expand this function to a fully independent sound effect.

| CV   | Denomination   | Value-Range | De-fault | Description  |
|------|--|-------------|----------|--|
| #374 | Coasting-Key (or Notching) for diesel sound projects | 0 - 29      | 0        | Function key that activates "Coasting", which forces the motor sound to a specified speed independent of the driving situation. Define the (sound) step in CV #375 (often used for idle sound while coasting).<br>= 0: does NOT mean F0, but rather that NO key is assigned for coasting.<br>= 1 - 28: One of the function keys F1 - F28 for "Coasting", 29 = F0 |
| #375 | Coasting step (or Notching)                          | 0 - 10      | 0        | Motor sound (speed) to be activated with the coasting key (as per CV #374), independent of the driving situation.<br>=0: Idle sound (typical coasting situations)<br>= 1 - 10: Sound step (Diesel engines typically have 5 to 10 notches, which can be activated with the coasting key (e.g. to represent auxiliary heating at standstill)).                     |
| #398 | Automatic Coasting                                   | 0 - 255     | 0        | The number of speed steps the train's speed has to be reduced within 0.5 seconds in order for the automatic coasting effect to set the motor sound to idle (without assigning a coasting key above). This effect does not occur at slowly reducing the speed steps.  |

It is especially expedient for diesel engines to be able to **raise the sound step manually** with a function key.

| CV   | Denomination   | Value-Range | De-fault | Description  |
|------|--|-------------|----------|--|
| #339 | Key for raising of diesel sound step                                 | 0 - 28      | 0        | Function key that raises the diesel sound to the minimum speed defined with CV #340.<br><br>See below if more keys for further speed raises are required.  |
| #340 | Diesel sound step, to which is to be raised, and possibly more keys. | 0 - 10      | 0        | The minimum diesel step the sound is to be raised to with the function key defined with CV #339. This CV can be extended (to include more function keys (in succession) by applying the formula: Minimum speed step + (16 * (Number of keys -1)) |

## 5.8 Random and Switch input sounds



| CV  | Denomination   | Value-Range                   | Def           | Description   |
|---|--|-------------------------------|---------------|---|
| #315  | Random generator Z1  | 0 - 255<br>=                  | 1             | The random generator generates internal pulses in irregular intervals that are used to playback a sound file assigned to the random generator. CV #315 defines the shortest possible interval between two consecutive pulses.<br><br>Sound samples are assigned to the random generator Z1 with the help of the CV #300 = 101 procedure, see above! By default, the compressor is assigned to Z1. |
|   | Minimal interval   | 0 - 255 sec                   |               |   |
| Special note to the random generator Z1: To start the air brake pump, which is optimized for Z1, immediately after the train stopped, the following settings are required:<br>CVs #315 and #316 have to be set on the same value (e.g. 30), and CV #154 has to have the value 16. |  |                               |               |   |
| #316  | Random generator Z1  | 0 - 255<br>=                  | 60            | CV #316 defines the maximum time interval between two consecutive pulses of the random generator Z1; the actually occurring pulses between the values in CV #315 and #316 are equally distributed.  |
|   | Highest interval   | 0 - 255 sec                   |               |   |
| #317  | Random generator Z1<br>Duration of playback                          | 0 - 255<br>=<br>0 - 255 sec   | 5             | The sound sample assigned to the random generator Z1 (most often the compressor) is played back for the timespan defined in CV #317.<br><br>= 0: Play back sound sample for the first time  |
| #318<br>#319<br>#320  | As above, however...<br>Random generator Z2                          | 0 - 255<br>0 - 255<br>0 - 255 | 20<br>80<br>5 | By default, Z2 is assigned for coal shoveling at stand-still.   |
| #321<br>#322<br>#323  | As above, however...<br>Random generator Z3                          | 0 - 255<br>0 - 255<br>0 - 255 | 30<br>90<br>3 | By default, Z3 is assigned for the injector at stand-still.   |
| #324<br>-<br>#338   | As above, however...<br>Random generator Z4 - Z8                     | 0 - 255<br>0 - 255<br>0 - 255 |               | At delivery this random generator is not used.  |
| #341  | Switch input 1<br>Duration of playback<br>SW version 5.00 and higher | 0 - 255<br>=<br>0 - 255 sec   | 0             | The sound sample allocated to switch input 1 is played back for the duration defined with this CV.<br><br>= 0: Play back sound sample for the first time  |

|      |  |                             |   |   |
|------|--|-----------------------------|---|---|
|      | higher   |                             |   |   |
| #342 | Switch input 2<br>Duration of playback<br>SW version 5.00 and higher | 0 - 255<br>=<br>0 - 255 sec | 0 | The sound sample allocated to switch input 2 is played back for the duration defined with this CV.<br><br>= 0: Play back sound sample for the first time  |
|      | Switch input 3<br>Duration of playback<br>SW version 5.00 and higher | 0 - 255<br>=<br>0 - 255 sec | 0 | The sound sample allocated to switch input 3 (as far as it is not used as cam sensor) is played back for the duration defined with this CV.<br><br>= 0: Play back sound sample for the first time |
| #392 | Switch input 4<br>Duration of playback<br>SW version 5.00 and higher | 0 - 255<br>=<br>0 - 255 sec | 0 | The sound sample allocated to switch input 4 is played back for the duration defined with this CV.<br><br>= 0: Play back sound sample for the first time  |

**6 Sound equalizing (filter) of the MS sound decoders**

Ab SW-Version 4.229



MS-Sound decoders of all types (from subminiature to large scale) allow the application of up to 6 filter stages (each with one of currently 7 filter types) to the audio signal reaching the loudspeaker. In case of "stereo" decoders also separately for both output channels (3 filter stages each, *not yet in SW version 4.229*).

For the filters and their parameters, the CVs are available on a CV page:

**CV-Page 145/2** (i.e. page pointer CV #31 = 145, CV #32 = 2), **CVs #257 - #280**

| CVs (from SW-Version 4.229)   | Description   |
|---|---|
| <p><b>CV-Page 145/2, 1. Filter</b><br/>                     CV #257 = Filter type<br/>                     CV #258 = Cut-off frequency<br/>                     CV #259 = Quality factor<br/>                     CV #260 = Amplification</p> | <p>Filter type: 0 = no Filter (deactivated)<br/>                     1 = Low pass   2 = High pass   3 = Bandpass<br/>                     4 = LowShelf   5 = HighShelf   6 = Notch   7 = Peak</p> <p>Cut-off frequency 64Hz to 16kHz:<br/>                     CV = (log(Cut-off frequency) * 32 / log(2)) - 192</p> <p>Quality factor 0 to 2:<br/>                     CV = (Quality factor * 128) - 1</p> <p>Amplification -12dB to +12dB:<br/>                     CV = Amplification * 32 / 3 + 127</p> |
| <p><b>CV-Page 145/2, 2. Filter</b><br/>                     CV #261 = Filter type<br/>                     CV #262 = Cut-off frequency<br/>                     CV #263 = Quality factor<br/>                     CV #264 = Amplification</p> |   |
| <p><b>CV-Page 145/2, 3. Filter</b><br/>                     CV #265 = Filter type<br/>                     CV #266 = Cut-off frequency<br/>                     CV #267 = Quality factor<br/>                     CV #268 = Amplification</p> |   |
| <p><b>CV-Page 145/2, 4. Filter</b><br/>                     CV #269 = Filter type<br/>                     CV #270 = Cut-off frequency<br/>                     CV #271 = Quality factor<br/>                     CV #272 = Amplification</p> |   |
| <p><b>CV-Page 145/2, 5. Filter</b><br/>                     CV #273 = Filter type<br/>                     CV #274 = Cut-off frequency<br/>                     CV #275 = Quality factor<br/>                     CV #276 = Amplification</p> |   |
| <p><b>CV-Page 145/2, 6. Filter</b><br/>                     CV #277 = Filter type<br/>                     CV #278 = Cut-off frequency<br/>                     CV #279 = Quality factor<br/>                     CV #280 = Amplification</p> |   |

In order to use the real-time filter setting, the MXULF must be connected to the PC via USB cable. Then the control panel is opened and the button for the filter dialog.

Example: Loudspeaker matching for LS8X12 (a rectangular loudspeaker from the ZIMO program)

- Frequencies that the loudspeaker reproduces too softly or too loudly are boosted or cut with peak filters - in this case cut around the resonance frequencies.
- Low frequencies, which the (small) speaker would not be able to reproduce anyway, are suppressed by high-pass to reduce the load on the speaker.

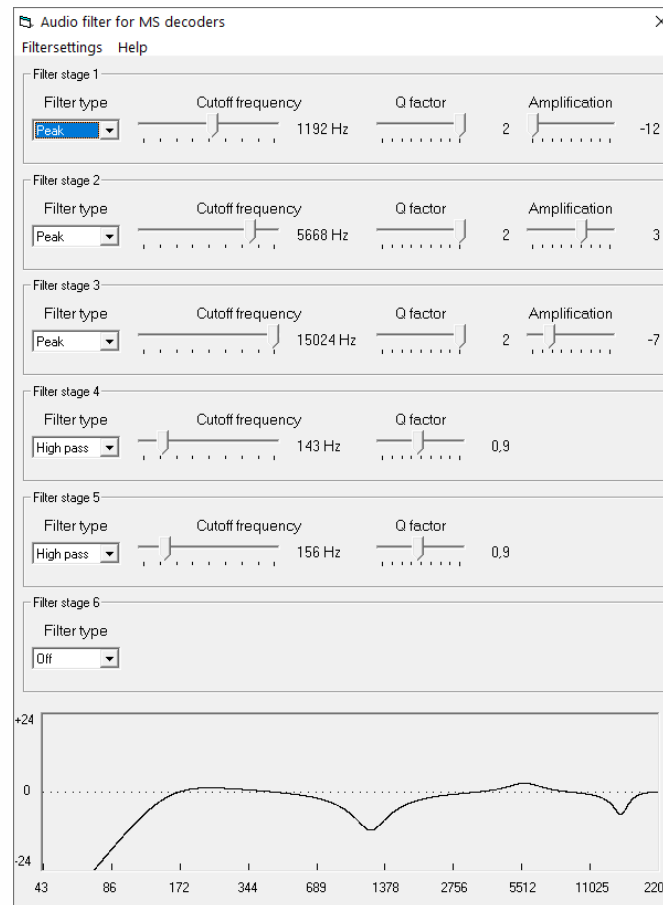

The speaker adjustment described here is only one of many possibilities opened up by equalizing!

**Convenient setting of the filters with ZPP-Konfig or ZSP:**

The software controller with the filters can be accessed via ZPP Config as well as via ZSP.



## 7 Installation and connection of the ZIMO decoder

### Separate rail connections from motor connections!

All direct connections in the original locomotive design between current collectors (wheels or rail wipers) and the motor must be **reliably separated from each other**; otherwise, the motor end stage may get damaged at power-up. The same goes for the **headlights and other additional accessories**, which must be completely isolated.

### Interference suppression components = motor control malfunctions?

Yes, sometimes!

Explanation: Motors of model railroad locomotives are often equipped with choke coils and capacitors, which are supposed to suppress or filter out electric noise caused by sparks arcing across the motor's brushes (causing poor TV reception etc.).

Such components impair the motor regulation. Compared to others, ZIMO decoders manage quite well and there is hardly a difference in performance with or without those components in place.

#### Typical problems and their fixes:

ROCO, BRAWA, HORNBY – usually no problems, no action required.

FLEISCHMANN H0 – with old round motor – choke coils are no problem; capacitors should be removed, especially the ones between the frame and motor (may destroy the decoder if left in place)! Newer Bühler motors – no problems so far.

TRIX H0 – choke coil between track and decoder plug should be removed! MINITRIX, FLEISCHMANN PICCOLO – very inconsistent; removing capacitors is often advantageous; choke coils on the other hand presented no problems so far.

Indicators of such components having a harmful effect are:

- generally unsatisfactory motor control, jerking when driving slowly,
- slow/weak corrections, the (large) choke coils could be to blame,

**Remedy:** Bridge (or remove) the choke coils with jumpers! Remove the capacitors. However, capacitors rarely have a negative influence.

### Interference suppression components = overcurrent shutdown?

Some loco boards from PIKO up to 2019 and other manufacturers installed such large capacitors between the motor connections that severely impede operation or even cause an overcurrent shutdown.

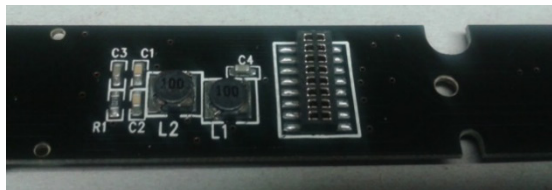

**Remedy:** The "harmful" capacitor on the PIKO locomotive circuit board is usually marked "C4" and must be removed. Normally, the locomotive circuit board has to be removed for this, because the capacitor is fitted on the underside.

### DC and AC Motors

This is the **most common circuit diagram** for installation in HO models, the wire colors apply to all wired decoders (ZIMO and third-party products)

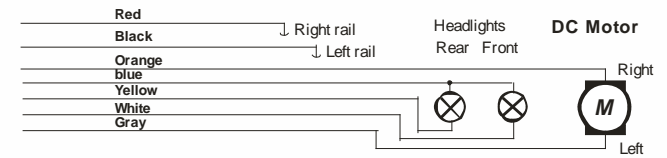

Two additional 1N4007 diodes (or equivalent – min 1 A) are required as shown in the diagram below when installing a decoder in a loco equipped with an AC motor (usually older Marklin or Hag engines). They can be obtained at your local electronic store.

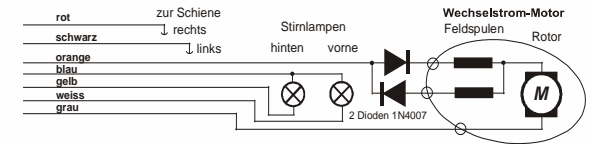

Most locomotives with AC motors get the power supplied by a third rail, which is of no significance as far as the motor hook-up is concerned. The above schematic is therefore valid for AC locomotives running on two or three rail track (instead of "right rail" and "left rail" think "outside rails" and "center rail").

### Function outputs FO1, FO2, FO3, FO4 ...:

The function outputs (i.e. FO1, FO2 ...) are wired in the same way as the headlight outputs. By default, FO1, FO2, etc. are to be switched with cab keys F1, F2, etc. Function mapping begins with CV #33, etc.

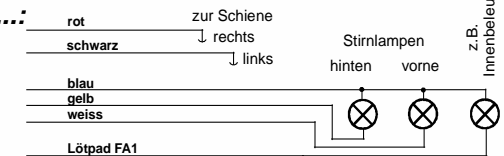

### Using logic level outputs:

In addition to the "normal" amplified function outputs, the MS and MN decoders also have so-called "logic level" outputs. Since these outputs are not amplified in the decoder, they provide 0 V voltage level for output and 3.3 V voltage level for input. Most logic level outputs alternatively use the connections of SUSI-Clock and SUSI-Data. These are converted to logic level outputs by CV #124, bit 7 = 1 (SUSI is then no longer present). Some decoders have additional outputs besides the SUSI outputs (e.g. MN180N18 and MS590N18), which can only be used as logic level outputs. With the MN decoders, the logic level outputs can be loaded with max. 0.5 mA, with the MS decoders, the logic level outputs can be loaded with max. 1.5 mA.

In order to be able to use the logic level outputs for consumers (digital couplers, smoke generators, light bulbs, LEDs), they must be amplified. This can be done with the ZIMO amplifier module M4000Z, a NPN transistor with a resistor at the base or a N-channel MOS-FET.

For an LED that does not require much current, e.g. because it does not have to shine very brightly, amplification of the logic level output is not absolutely necessary. In this case the LED can be connected together with a series resistor to the logic level output (= positive pole) and to the ground of the decoder. The brown wire of a **M4000Z amplifier module** is connected with the logic level output of the decoder.

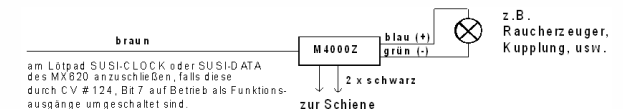

**Connecting an electric (un)coupler (System "Krois"):**

In order to prevent damage to the delicate core of an uncoupler from continuous power, appropriate adjustments can be made with special CVs for one or several function outputs. To define any output to an uncoupler output:

First, write the value "48" to the special effect CVs for the outputs an uncoupler is connected to (e.g., CV #127 for output #1, CV #128 for output #2 etc.).

Next define a limit for the uncoupler's activation time in CV #115 (see CV-table):

With the "Krois couplers", it is recommended to use a value of "60", "70" or "80" for CV #115; this means that the pull-in voltage (full track voltage) is limited to 2, 3 or 4 seconds. A reduced "hold" voltage is not required for Krois, that is why the ones digit is left at 0. Other brand couplers may need a reduced hold voltage though, like the ones from ROCO for example.

For automatic loco disengaging or automatic coupler unloading and loco disengaging ("coupler waltz") see CV #116 and chapter Configuration of Electric Uncouplers

**Connecting one or several servos to:**

"Small" decoder (for H0, TT, N):

The two "SUSI pins" on the decoder can be switched to operate servos; see chapter "3.24 SUSI pins: switchable to SUSI or I<sup>2</sup>C interface, logic level inputs and outputs or servo control lines....", CVs #181, #182, ...). Connect the servo's control wires to the SUSI pins.

Power for the servos (5 - 6 V) must come from an external power supply for the "small" decoders (for H0, TT, N) (see circuit with 5V voltage regulator in the picture on the right).

Large-scale decoder (0, G, 1, ...):

These decoders have their own dedicated servo connections and a built-in power supply (therefore no need to switch the SUSI outputs for servo control, and no external supply is required).

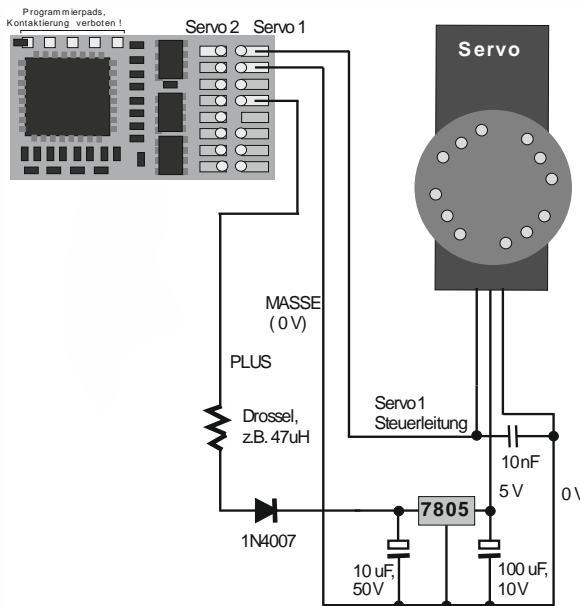

**Connecting speaker, cam sensor:**

Depending on the type (>= 3 W sound or 1 W sound), a 4 ohm or 8 ohm LOUDSPEAKER can be used, or several interconnected speakers with a total impedance of 4 ohm or 8 ohm. Speakers with higher impedance are of course also allowed, but with a loss in volume.

An additional tweeter (also 8 ohm or higher) can be connected, if desired; the connection should be made via a bipolar capacitor (10 µF bipolar for 2 kHz frequency) to protect the tweeter.

CAM SENSOR: ZIMO Sound Decoders are normally set to the "simulated cam sensor", which is adjusted by using CV #267 and #354. If a "real" cam sensor is to be used, CV #268 must be set to 1 or 2, depending on whether every pulse or every second pulse should trigger a chuff. Mechanical contact Reed switches, optical switches and Hall Effect switches are suitable as cam sensors.

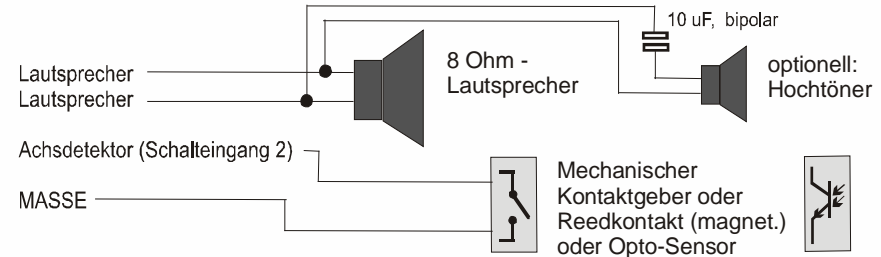

**Connecting smoke generators to steam or diesel engines:**

"Seuthe" 18 V smoke generators:

In addition to a simple ON/OFF function and a function output of your choice, these decoders are also capable of adapting the smoke volume to the load (almost no smoke at standstill, little smoke while cruising, heavy smoke at start-up etc.).

The smoke generator must be connected to one of the function outputs FO1 to FO6 and the selected output must be programmed with the associated special effect CV (CV #127 for FO1, CV #128 for FO2 etc.) for the desired effect; in this case for load dependent smoke for steam engines (effect code "72") or load dependent smoke for diesels (effect code "80").

EXAMPLE: - Typical characteristic for a track voltage set around 20 V with above smoke generator:

CV #137 = 70 - 90: little smoke at standstill.

CV #138 = 200: The smoke generator output is increased to about 80 % of its maximum capacity beginning with speed step 1 (lowest speed step), which produces relatively heavy smoke.

CV #139 = 255: The smoke generator is driven to its maximum, which results in thick smoke under heavy acceleration.

**Synchronized steam chuffs or typical diesel smoke with fan-controlled smoke generators:**

ZIMO sound decoders, with the help of a smoke generator with built-in fan, can produce steam puffs synchronized with sound chuffs or load dependent diesel smoke (i.e., diesel engine smoke at start-up, controlled by the sound project) without additional electronic components.

The heating element of the smoke generator is connected – as in the example above with the "Seuthe" generator – to FO1 - FO6 and configured with the appropriate CV for the desired effect (i.e., "72" for steam or "80" for diesel). The fan is connected to the function output FO4 (or FO2 in exceptional cases such as the MX646); the other wire of the fan motor often requires a low voltage (check with the manufacturer) and is therefore connected to an external voltage regulator or – if the fan motor requires 5 V – to the 5 V supply of the decoder, if such an output is available.

The CVs must be programmed as follows:

CV #137, #138, #139 = 60, 90, 120 respectively: (IMPORTANT) if the heating element cannot operate at full track voltage, it must be limited by programming suitable values in CV #137, #138 and #139.

CV #133 = 1: (IMPORTANT) this configures output FO4 as a fan output.

CV #353 = ... i.e., 10: shuts the smoke generator off automatically to prevent overheating.

In this example ("10") after 250 seconds.

CV #351, #352 = ...: Only for diesel engines when special effect code "80" is selected in the applicable CV for FO1 - FO6. This defines the fan speed (voltage) for start-up (default: maximum smoke) and cruising (default: medium smoke); see CV table.



CV #355 =...: For steam and diesel engines. Defines the fan speed (voltage) at standstill (usually for very little smoke output).

## 8 CV - Overview; CVs in numerical order

This overview summarizes all CVs in numerical order; mostly identically adopted from the descriptions in the preceding (context-related) chapters of this manual, in some cases shortened. In this CV overview there are **NO notes to SW versions (from SW version ...; see context-related chapters)**.

*Red column on the left: Denotes the chapter in this manual the CV is described in its context - by clicking you can jump directly to the chapter*

| CV  | Denomination   | Range                             | Default                     | Description  |
|-----|--|-----------------------------------|-----------------------------|--|
| 3.4 | #1<br>Locomotive address   | DCC:<br>1 - 127<br>MM:<br>1 - 255 | 3                           | The "short" vehicle address (DCC, MM)<br>In case of DCC operation:<br>Primary address as per CV #1 is only valid, if CV #29 (basic configuration), Bit 5 = 0.<br>Otherwise, the address per CVs #17 & #18 is valid, i.e. if CV #29, Bit 5 = 1.   |
| 3.6 | #2<br>Start Voltage $V_{start}$<br>3-point speed table, if CV #29, bit 4 = 0 | 1 - 255                           | 1                           | Internal speed step (1 - 255) applied as <b>lowest</b> external speed step (= speed step 1) (applies to 14, 28, or 128 speed step modes) = 1: lowest possible speed  |
| 3.7 | #3<br>Acceleration time  | 0 - 255                           | (2)                         | The value multiplied by 0.9 equals acceleration time in seconds from stop to full speed.<br>The effective default value for sound decoders is usually not the value given here, but is determined by the loaded sound project.   |
| 3.7 | #4<br>Braking time (Deceleration)  | 0 - 255                           | (1)                         | This CV, multiplied by 0.9, provides the time in sec for the deceleration from full speed to stop.<br>The actual default value: see above!   |
| 3.6 | #5<br>Top Speed $V_{high}$<br>3-point speed table, if CV #29, bit 4 = 0      | 0 - 255                           | 0, 1<br>equals 255          | Internal speed step (1 - 255) applied as <b>highest</b> external speed step (i.e. for the external speed step 14, 28 or 128, depending on the speed step mode according to CV #29, bit 1 = 0:<br>=0: equals 255 as highest speed step<br>=1: equals 255 as highest speed step  |
| 3.6 | #6<br>Medium Speed $V_{mid}$   | 1, ¼ to ½ of the Value in CV #5   | 1<br>(= @ 1/3 of top speed) | Internal speed step (1 - 255) for <b>medium</b> external speed step (i.e. for the external speed step 7, 14 or 64, depending on the speed step mode 14, 28 or 128 according to CV #29, bit 1) "1" = default (Medium speed is set to one third of the top speed. I.e. if CV #5 = 255 the curve is the same as if CV #6 would be programmed to 85).<br>The speed curve resulting from CVs #2, #5 and #6 is automatically smoothed out, therefore no sharp bends. |
| 3.3 | #7<br>SW version number<br>Also see CV #65<br>Sub-Version number             | Read only                         | -                           | This CV holds the firmware version number currently in the decoder.<br>CV #7 = number of the "main" version<br>CV #65 = Sub-version number   |

| CV         | Denomination  | Range  | Default                                    | Description   |
|------------|---|--|--|---|
| 3.3        | #8<br>Manufacturer ID and<br>HARD RESET<br>by CV #8 = „8“ or CV #8 = 0  | Read only<br>always shows "145" for ZIMO ID<br><br>Pseudo-programming see descr. on the right            | 145<br>(= ZIMO)                            | Reading out this CV always result in "145" ("10010001"), the number issued for ZIMO by the NMRA.<br>Additionally, this CV is used to start various resetting procedures by Pseudo programming.<br>"Pseudo programming" means that the entered value is not really stored, but rather used to start a defined action.<br>CV #8 = "3" → 21MTC decoder FO3, FO4 logic-level<br>CV #8 = "4" → 21MTC decoder FO3, FO4 normal<br>CV #8 = "5" → 21MTC decoder FO5, FO6 logic-level<br>CV #8 = "6" → 21MTC decoder FO5, FO6 normal<br>CV #8 = "8" → HARD RESET (NMRA standard);<br>all CVs return to the last active CV set or <b>sound project</b> , or (if no such set was active before) to the default values listed in this CV table.<br>CV #8 = "0" → NOT recommended (service use only), default values of the table |
| 3.6        | #9<br>Motor control-period or frequency and<br>EMF-sampling Rate (sampling rate, Sampling time)<br><br>Total PWM period | 55<br>High frequency, medium sampling rate.<br><br>01 - 99<br>High frequency with modified sampling rate | 55<br>High frequency, medium Sampling rate | = 55: Default motor control with high frequency (20 kHz), medium EMF sampling rate that adjusts between 200Hz (low speed) and 50Hz and medium EMF sampling time.<br>= 0: equal to 0 (is converted automatically)<br><> 55 and <> 0: Modification of the default setting, each divided in: tens digit for sampling rate and ones digit (sampling time).<br>Tens digit 1 - 4: Sampling rate lower than default (less noise)<br>Tens digit 6 - 9: Sampling rate higher than default (to combat juddering!)<br>Ones digit 1 - 4: EMF-sampling time shorter than by default (works well for Faulhaber, Maxxon, ... less noise, more power)<br>Ones digit 5 - 9: EMF-sampling time longer than default (may be needed for round motors or similar)  |
| 3.1        | #10<br>Motorola Subsequent addresses  | 0-3  | 0  | Decimal:<br>0= No Subsequent address<br>1= One Subsequent address for F5-F8<br>2= Two Subsequent addresses for F5-F12<br>3= Three Subsequent addresses for F5-F16   |
| 3.1<br>3.5 | #12<br>Possible operating modes   | -  | 127  | Bit 0 - DC analog 0 = disabled 1 = enabled<br>Bit 2 - DCC NOT deactivatable 1 = enabled<br>Bit 4 - AC analog 0 = disabled 1 = enabled<br>Bit 5 - MM 0 = disabled 1 = enabled<br>Bit 6 - mfx 0 = disabled 1 = enabled<br>Value 0 = all modes enabled   |



|     | CV         | Denomination  | Range   | Default                                   | Description  |
|-----|------------|---|---|---|--|
| 3.5 | #13<br>#14 | Functions F1 - F8<br>Functions<br>F0, F9 - F12<br>in analog operation<br>and  | (CV #13)<br>0 - 255   | (CV #13)<br>0 (MN)<br>128 (MS)            | Bit 0 = 0: F1 is OFF in analog mode<br>= 1: ... ON ...<br>Bit 1 = 0: F2 is OFF in analog mode<br>= 1: ... ON ...<br>..... F3, F4, F5, F6, F7<br>Bit 7 = 0: F8 is OFF in analog mode<br>= 1: ... ON ...<br>Bit 0 = 0: F0 (forw) OFF in analog mode<br>= 1: ... ON ...<br>Bit 1 = 0: F0 (rev) is OFF in analog mode<br>= 1: ... ON ...<br>..... F9, F10, F11<br>Bit 5 = 0: F12 is OFF in analog mode<br>= 1: ... ON ...<br>Bit 6 = 0: Analog operation with acceleration and deceleration according to CVs #3 and #4; useful for sound<br>= 1: Analog operation <b>without</b> effect, i.e. without acceleration and deceleration according to CV #3 and #4.<br>This is like a classical analog operation. |
|     |            | Acceleration/<br>Deceleration, control<br>in analog operation   | (CV #14)<br>0 - 255   | (CV #14)<br>67<br>therefore<br>Bit 6 = 1: |  |
| 3.4 | #15<br>#16 | Decoder Lock  | 0 - 255<br>0 - 255  | 0<br>0                                    | The decoder lock is used to access the CVs of several decoders with identical address separately.<br>The CVs #16 of each decoder are programmed to different values before installation. If necessary, the CV #15 of this decoder is reprogrammed to the value of "its" CV #16 > all CVs addressable.<br>CV #15 <u>and</u> #16 = 0: Decoder is not locked.   |
| 3.4 | #17<br>#18 | Extended (long) address   | 128<br>-<br>10239   | 192<br>-<br>128                           | The long ("extended") DCC address applies to addresses >127.<br>The loco address per CVs #17 & #18 is valid, if CV #29 (basic configuration), bit 5 = 1.   |
| 3.4 | #19        | Consist address   | 0,<br>1 - 127<br>129 - 255<br>(= 1 - 127 with inverted Direction) | 0   | Alternate loco address for consist function:<br>If CV #19 > 0: Speed and direction is governed by this consist address (not the individual address in CV #1 or #17&18); functions are controlled by either the consist address or individual address, see CVs #21 & 22.<br>Bit 7 = 1: Driving direction reversed   |
| 3.4 | #20        | Extended consist address AND (regardless of whether extended consist address is used)<br>Bit 7: Activating the RailCom feedback for consist address | 0 - 102<br>128 - 130  | 0   | "Extended" consist address: the value defined in CV #20 is multiplied by 100 and added to the value in CV #19, which then results in the address in consist operation.<br>E.g. CV #20 = 12, CV #19=34 equals addr. 1234;<br>CV #20=100, CV #19=00 equals addr. 10000<br>Bit 7 = 1: on RailCom address the Channel-2 messages (speed, direction information, etc.) are sent out, and in Channel-1 (on all addresses except own Consist) Consist address is reported.<br>The consist address is CV #19 (if CV #20 =0); or CV #19 and #20 (see above, if CV #20 is not 0).  |
| 3.4 | #21        | Functions F1 - F8<br>in consist operation   | 0 - 255   | 0   | Functions defined here will be controlled by the consist address.<br>Bit 0 = 0: F1 controlled by individual address<br>= 1: ... by consist address<br>Bit 1 = 0: F2 controlled by individual address<br>= 1: ... by consist address  |

|                      | CV  | Denomination  | Range   | Default | Description   |
|----------------------|-----|---|---------|---------|---|
| 3.4                  | #22 | Functions<br>F0 forw. rev.<br>in consist function<br><br>and<br><br>Activating<br>Auto-Consist  | 0 - 255 | 0       | ..... F3, F4, F5, F6, F7<br>Bit 7 = 0: F8 controlled by individual address<br>= 1: ... by consist address<br>Select whether the headlights are controlled by the consist address or individual address.<br>Bit 0 = 0: F0 (forw.) controlled by individual address<br>= 1: ...by consist address<br>Bit 1 = 0: F0 (rev.) controlled by individual address<br>= 1: ... by consist address<br>Bit 2 = 0: F9 (forw.) controlled by individual address<br>= 1: ... by consist address<br>Bit 3 = 0: F10 (forw.) controlled by individual address<br>= 1: ... by consist address<br>Bit 4 = 0: F11 (forw.) controlled by individual address<br>= 1: ... by consist address<br>Bit 5 = 0: F12 (forw.) controlled by individual address<br>= 1: ... by consist address<br>Bit 7 = 1: F13 - F27 (all!) ... by consist address<br>Bit 6 = 1: <b>Auto-Consist</b> : The system changes automatically between individual and consist address, if one of the two addresses has speed 0 and the other has speed >0.   |
|                      |     |   |         |         |   |
| 3.7                  | #23 | Acceleration variation  | 0 - 255 | 0       | For a temporary elevation/decrease (Bit 7 = 0/1) of the acceleration time defined in CV #3.   |
| 3.7                  | #24 | Deceleration variation  | 0 - 255 | 0       | For a temporary elevation/decrease (Bit 7 = 0/1) of the deceleration time defined in CV #4.   |
| 3.1<br>3.9 0<br>3.11 | #27 | BRAKING MODES:<br><br>Position-dependent<br>Stopping<br>("before a red signal")<br>or driving slowly<br>by<br>"asymmetrical DCC signal" ("Lenz ABC")<br>See chapter<br>"3.10 Stop in front of a red signal and driving slowly by "asymmetrical DCC-Signal" stops (Lenz ABC)... "<br>or "ZIMO HLU"<br>(see chapter 3.9 ZIMO "signal-controlled speed influence" (HLU))<br>Automatic stopping by DC brake section ("Märklin brake section")<br>see chapter<br>"3.11 DC Brake Sections, "Märklin brake mode" |         |         | 0 =<br>ABC not active,<br>HLU active,<br>other brake sections not active<br>Bit 0 <u>and</u> Bit 1 = 0: ABC not activated; no stopping<br>Bit 0 = 1: Stops are initiated if the voltage in the right rail (in direction of travel) is higher than in the left rail. This (CV #27 = 1) is the usual ABC application)<br>Bit 1 = 1: ABC stops are initiated if the voltage in the left rail (in direction of travel) is higher than in the right rail.<br>If bit 0 <u>or</u> bit 1 = 1 (only one of the two bits is set): Stopping is directional, i.e. only in direction of travel to the signal, travelling in opposite direction has no effect.<br>Bit 0 <u>and</u> Bit 1 = 1: Stops are independent of direction of travel. See chapter "3.10 Stop in front of a red signal and driving slowly by "asymmetrical DCC-Signal" stops (Lenz ABC)"<br>Bit 4 - DC braking section, if polarity is reversed<br>0 = disabled 1 = enabled<br>Bit 5 - DC braking section, if polarity is equal to direction of travel<br>0 = disabled 1 = enabled<br>Bit 4 <u>and</u> bit 5 = 1 (CV #27 = 48): stopping when DC voltage (e.g. by a diode) independent of the polarity ("Märklin brake section") |
|                      |     |   |         |         |   |





|                                       | CV                              | Denomination  | Range                  | Default   | Description   |
|---------------------------------------|---------------------------------|---|------------------------|---|---|
| 3.1                                   | #28                             | RailCom Configuration   | 0, 1, 2, 3, 65, 66, 67 | 3 resp. 67 (for Bit 6)  | Bit 0 - RailCom Channel 1 (Broadcast)<br>Bit 1 - RailCom Channel 2 (Data)<br>Bit 6 - High voltage RailCom (large scale decoders on!)<br>for all Bits: 0 = OFF 1 = ON  |
| 3.1<br>3.4<br>3.5<br>3.6<br>3.24<br>4 | #29                             | Basic Configuration   | 0 - 63                 | 14 = 0000 1110<br>Bit 3 = 1 (RailCom is switched on), and Bits 1,2 = 1 (28 or 128 speed steps and automatic analog operation enabled) | Bit 0 - Train direction:<br>0 = normal, 1 = inverse<br>Bit 1 - number of speed steps<br>0 = 14, 1 = 28/128 speed steps<br>Bit 2 - automatic change to analog operation<br>0 = disabled, 1 = enabled<br>Bit 3 - RailCom („bi-directional communication“)<br>0 = deactivated 1 = <b>activated</b><br>Bit 4 - Individual speed table:<br>0 = off, CVs #2, #5 and #6 are active.<br>1 = on, according to CVs #67 – #94<br>Bit 5 - Decoder address:<br>0 = primary address as per CV #1<br>1 = ext. address as per CVs #17 & #18 |
| 3.14                                  | #33                             | NMRA Function mapping F0  | 0 - 255                | 1   | Function mapping for F0 forward   |
| 3.14                                  | #34                             | NMRA Function mapping F0  | 0 - 255                | 2   | Function mapping for F0 reverse   |
| 3.14                                  | #35<br>...<br>#46               | Function mapping F1 - F12   | 0 - 255                | 4, 8, 2, 4, 8, ...  | Function mapping for F1 - F12   |
| 3.9 0                                 | #49                             | Signal controlled (HLU, ABC) Acceleration   | 0 - 255                | 0   | ZIMO signal-controlled speed influence method (HLU) using MX9 or StEin:<br>or<br>when using the “asymmetrical DCC signal” stopping method:<br>The value multiplied by 0.4 equals acceleration time in seconds from stop to full speed.<br>Only CV #3 OR CV #49 is used, depending on which value is higher.   |
| 3.9 0                                 | #50                             | Signal controlled (HLU, ABC) braking distance   | 0 - 255                | 0   | ZIMO signal-controlled speed influence (HLU) with ZIMO MX9 track section module or StEin<br>or<br>when using the “asymmetrical DCC signal” stopping method:<br>The value multiplied by 0.4 equals deceleration time in seconds from full speed to stop.<br>Only CV #4 OR CV #50 is used, depending on which value is higher.  |
| 3.9                                   | #51<br>#52<br>#53<br>#54<br>#55 | Signal controlled (HLU) speed limits #52 for “U” (Ultra low) #54 for “L” (Low speed) #51, #53, #55 intermediate steps | 0 - 255                | 20<br>40 (U)<br>70<br>110 (L)<br>180  | ZIMO signal-controlled speed influence method (HLU) using MX9 or StEin:<br>Defines the internal speed steps for each of the 5 speed limits generated by HLU.  |
| 3.6                                   | #56                             | P and I value   | 0, 11 - 99 modified    | 55 medium   | = 55: Default motor control using medium values in PID parameters P and I (Diff = 0).   |

|      | CV  | Denomination   | Range        | Default     | Description   |
|------|-----|--|--------------|-------------|---|
|      |     | for PID motor regulation (= EMF-load balance control)<br><br>The value of this CV will be automatically transferred to CVs #147 - #149 | Setting      | PID Setting | = 0: equal to 0 (is converted automatically)<br><> 55 and <> 0: modified settings<br>Tens digit 1 - 4: Proportional value of the PID-motor regulation, lower than default<br>Tens digit 6 - 9: Proportional value of the PID-motor regulation, higher than default<br>Ones digit 1 - 4: Integral value of the PID regulation lower than default<br>Ones digit 6 - 9: Integral value of the PID regulation higher than default<br>Typical test values against jerky driving:<br>CV #56 = 55 (default) → 33, 77, 73, 71, ...<br><b>ATTENTION:</b> The values 10, 20, 30, 40, 50, 60, 70, 80 and 90 are NOT allowed! |
| 3.6  | #57 | Voltage reference  | 0, 100 - 255 | 0           | Absolute voltage in tenth of a volt applied to the motor at full speed (max. throttle setting). A useful (and well functioning) range is 10 to 24 V (i.e. 100-240), and lower than the expected track voltage.<br>EXAMPLE: A system from another manufacturer is set to 22 V at idle but drops to 16 V under load: A good setting would be CV #57 = 140 - 150.<br>CV #57 = 0: automatically adapts to the track voltage (relative reference); only useful with stabilized track voltage.  |
| 3.6  | #58 | BEMF intensity<br><br>SW version 5.00 and higher   | 0 - 255      | 255         | Intensity of back-EMF control at the lowest speed step.<br>EXAMPLES:<br>CV #58 = 0: no back-EMF (like unregulated decoders),<br>CV #58 = 150: medium compensation,<br>CV #58 = 255: maximum compensation.   |
|      | #59 |  |              |             | Not implemented   |
| 3.19 | #60 | Dimming the function outputs = voltage reduction of the function outputs by PWM<br><br>Generally, this affects all function outputs.   | 0 - 255      | 0           | Reduction of function output voltage with PWM (pulse width modulation), to reduce the light's brightness, for example.<br>EXAMPLES:<br>CV #60 = 0 or 255: full voltage<br>CV #60 = 170: 2/3 of full voltage<br>CV #60 = 204: 80 percent of full voltage   |
| 3.15 | #61 | Extended Mapping   | 0, 97        | 0           | = 97: NMRA mapping “without left-shift”   |
| 3.20 | #62 | afterglow brake light  | 0 - 255      | 0           | Brake light (code 001110xx in CV #125ff): Afterglow in tenths of a second (i.e. range 0 to 25 sec) at standstill after stopping   |
| 3.20 | #63 | Modifications of lighting effects  | 0 - 99       | 51          | Tens digit: Changing cycle time for various effects (0 - 9, default 5), or brighting up at soft start at 001101 (0 - 09 sec)<br>Ones digit: Extends off-time  |
| 3.20 | #64 | Ditchlight modification  | 0 - 255      | 0           | Bit 7 - 4: define a ditch light key (function key+1)*16 consequent: 0=F2, 1=F0, 2=F1,... 15=F14<br>Bit 3 - 0: Ditch light OFF time modification [s]   |
| 3.3  | #65 | SW Sub-version number<br>Also see CV #7 for Version number   | Read only    | -           | If there are subversions to the SW version in CV #7, it is read out in CV #65.<br>The entire SW version number is thus composed of CVs #7 and #65 (i.e. 28.15).   |



|             | CV        | Denomination  | Range                                 | Default      | Description   |
|-------------|-----------|---|---------------------------------------|--------------|---|
| 3.6         | #66       | Directional speed trimming  | 0 - 127<br>0 - 127                    | 0<br>0       | Speed step multiplication by "n/128" (n is the trim value in this CV): #66: for forward direction; #95: for reverse direction   |
| 3.6         | #67 - #94 | Free (28-point) speed table if CV #29, bit 4 = 1  | 0 - 255                               | *)           | internal speed steps (each 1 - 255) for each of the 28 external steps.<br>*) The 28-point default curve is also bent, emphasizing the lower speed range.  |
| 3.6         | #95       | Directional speed trimming  | 0 - 127<br>0 - 127                    | 0<br>0       | Speed step multiplication by "n/128" (n is the trim value in this CV): #66: for forward direction; #95: for reverse direction   |
| 3.4         | #97       | Change between individual and consist address by function key   | 0 - 28                                | 0            | With this key, you can switch between the main address of the decoder (on CV #1 or CVs #17, #18) or the consist address by pressing this key (only on the main address)   |
| 3.16        | #107      | Turn off lights (i.e. front headlights AND the - according to CV #107 - additionally defined function output) at driver's cab 1 (front) | 0 - 220                               | 0            | The value of this CV is calculated as follows:<br>Number of a function output (FO1... FO6) x 32 + number of a function key (F1, F2, ...F28)<br>→ ... value of CV #107.<br>Function key: The key (F1-F28) with which ALL lights on the cab's side are turned off, i.e. output "front light" AND function outputs: e.g. rear lights on this side.   |
| 3.16        | #108      | at driver's cab 2 (back)  | 0 - 255                               | 0            | As CV #107, but for other side of the loco.   |
| 3.4<br>3.16 | #109      | Automatic unilateral light suppression Add. Fu-output at side 1   | Bit 7 = 0.1:<br>Bit 7 = 0.1:<br>1 - 6 |              | If CV #109, bit 7=1 and CV #110, bit 7=1, the light suppression on the driver's cab side in consist operation is activated automatically.<br>Fu output is turned off with CV #107.  |
| 3.4<br>3.16 | #110      | Automatic unilateral light suppression Add. Fu-output at side 2   | Bit 7 = 0.1:<br>Bit 7 = 0.1:<br>1 - 6 |              | If CV #109, bit 7=1 and CV #110, bit 7=1, the light suppression on the driver's cab side in consist operation is activated automatically.<br>Function output is turned off with CV #108.  |
| 3.11        | #111      | Emergency Delay time  | 0 - 255                               | 0            | This CV value is valid for emergency stop instead of CV #4, i.e. for single stop and collective stop emerg.   |
| 3.6         | #112      | Special ZIMO Configuration bits   | 0 - 255                               | 4 = 00000100 | Bit 2 = 0: ZIMO loco number recognition OFF = 1: ZIMO loco number recognition ON  |
| 3.19        | #114      | Dim Mask 1 = Excludes specific function outputs from dimming as per CV #60<br><br>Also see Addition to CV #152                          | Bits 0 - 7                            | 0            | Enter function outputs that are <b>not</b> to be dimmed by CV #60. These outputs will receive the full voltage from the pin they are connected to. That is, either full track voltage or low voltage from a low-voltage pin.<br>Bit 0 - front headlights<br>Bit 1 - rear headlights<br>Bit 2 - function output FO1, Bit 3 - FO2,<br>Bit 4 - function output FO3, Bit 5 - FO4,<br>Bit 6 - function output FO5, Bit 7 - FO6,<br>Respective Bit = 0: Output will, if switched on, be dimmed with voltage according to CV #60.<br>Respective Bit = 1: Output will, if switched on, not be dimmed, i.e. it will be supplied with full voltage when switched on.<br><u>EXAMPLE:</u> |

|              | CV   | Denomination   | Range                    | Default | Description  |
|--------------|------|--|--------------------------|---------|--|
|              |      |  |                          |         | CV #114 = 60: FO1, FO2, FO3, FO4 will <b>not</b> be dimmed; i.e. only the headlights are reduced in brightness.  |
| 3.19<br>3.22 | #115 | Uncoupler control Activation time or<br><br>CV #115 can be used as alternative "second dimming value." | 0 - 99                   | 0       | The uncoupler function is only active if "uncoupler" is selected (value 48) in one of the CVs #125 - #132, #159, #160: Tens digit (0 - 9): Time in seconds according to the following table the coupler receives full voltage (pull-in time):<br>Value: 0 1 2 3 4 5 6 7 8 9<br>sec: 0 0.1 0.2 0.4 0.8 1 2 3 4 5<br>Ones digit (0 to 9): hold-in power in percent of track voltage, 0% - 90%. Applied after the pull-in time elapsed (necessary for ROCO coupler, not needed for KROIS coupler).<br>or ones digit as "second dimming value" (by setting the tens digit to "0") from 0% to 90% (according to ones digit) |
| 3.22         | #116 | Automatic Disengagement during uncoupling = "Automatic uncoupling"                                     | 0, 1 - 99,<br>0, 1 - 199 | 0       | Tens digit (0 - 9): Length of time the loco should move away (disengage) from the train; coding as in CV #115.<br>Ones digit (1 - 9) x 4 = Internal speed step applied for disengagement (Acceleration per CV #3)<br>Ones digit = 0: Standstill<br>Hundredths digit<br>= 0: No unloading.<br>= 1: Coupler unloading: engine moves toward train in order to relieve coupler tension, before uncoupling and disengaging from the train.<br><u>EXAMPLE:</u><br>CV #115 = 60 (driving off after disengagement for 2 sec), and<br>CV #116 = 155 (active pushing to disengage, speed step 20, 1 sec)                         |
| 3.20         | #117 | Flasher functions Outputs are assigned in CV #118. Flashing mask                                       | 0 - 99                   | 0       | Duty cycle for flasher function:<br>Tens digit: Off / Ones digit: On<br>(0 = 100msec, 1 = 200msec.....9 = 1 sec)<br><u>Example:</u><br>CV #117 = 55: Flashes evenly at 1 a second interval. i.e. identical on and off times  |
| 3.20         | #118 | Flashing mask = Allocation of Function outputs to the flashing rhythm CV #117                          | Bits 0 - 7               | 0       | Selected function outputs will flash when turned ON.<br>Bit 0 - front headlights<br>Bit 1 - rear headlights<br>Bit 2 - for function output FO1, Bit 3 - ...FO2<br>Bit 4 - ... FO3, Bit 5 - for function output FO4.<br>Respective Bit = 0: No flasher<br>Respective Bit = 1: Output flashes when turned ON.<br>Bit 6 = 1: FO2 flashes inverse<br>Bit 7 = 1: FO4 flashes inverse<br>(for alternate flashing, i.e. wig-wag)<br><u>EXAMPLES:</u><br>CV #118 = 12: Function outputs FO1 and FO2 are assigned for flashing lights.<br>CV #118 = 168: Outputs FO2 and FO4 shall flash alternatively, if both are turned on   |
| 3.19         | #119 | Low beam mask for F6 = Allocation of Function outputs as (for example)                                 | Bits 0 - 7               | 0       | Selected outputs will dim, according to the dim value in CV #60, when the F6 key is actuated.<br>Typical application: Low/high beam<br>Bit 0 - front headlights<br>Bit 1 - rear headlights   |



|      | CV   | Denomination  | Range                      | Default    | Description  |
|------|------|---|----------------------------|------------|--|
|      |      | low/high beam<br><b>ATTENTION:</b><br>Certain settings in CV #154 (Special output configurations for OEM projects) the meaning of the following CVs changes:<br>#119, #120, i.e. those are not low beam mask anymore.   |                            |            | Bit 2 - function output FO1,<br>Bit 3 - function output FO2,<br>Bit 4 - function output FO3,<br>Bit 5 - function output FO4,<br>Bit 6 - function output FO5.<br>Respective Bit = 0: Output will not be dimmed,<br>Respective Bit = 1: Output will be dimmed with F6 to value defined in CV #60.<br>Bit 7 = 0: "normal" effect of F6.<br>= 1: Inverted effect of F6.<br><b>EXAMPLE:</b><br>CV #119 = 131: Headlights shall be switched between high and low beam with F6 (F6 = 1).  |
| 3.19 | #120 | Low beam mask for F7  | Bits 0 - 7                 |            | Same as CV #119 but with F7 as low beam key.   |
| 3.7  | #123 | Adaptive Acceleration and deceleration momentum   | 0 - 99                     | 0          | Raising or lowering the speed to the next internal step occurs only if the preceding step is almost reached. The tolerance for reaching the preceding step can be defined by this CV (the smaller this value the smoother the acceleration/deceleration).<br>Value 0 = no adaptive accel. or decel.<br>Tens digit: 0 - 9 for acceleration (1 = strong effect)<br>Ones digit: 0 - 9 for deceleration<br>= 11: strongest effect;   |
| 3.24 | #124 | <b>ATTENTION:</b><br>Bits 2, 3, 4, 6 (i.e. selection for shunting key functions) are only valid if CVs #155 and #156 = 0 (These allow extended selection and are preferred for new projects).<br>Shunt key functions: Half-speed, acceleration deactivation<br><b>Bits 0,1</b> (i.e. type of acceleration deactivation) are always valid, also together with CVs #155, #156<br><br><b>Bit 7:</b><br>Switchover SUSI - Logic level outputs | Bits 0 - 4, 6<br><br>Bit 7 | 0<br><br>0 | Selection of a shunting key to activate the HALF SPEED:<br>Bit 4 = 1 (and bit 3 = 0): F3 as half-speed key<br>Bit 3 = 1 (and bit 4 = 0): F7 as half-speed key<br>Selection of a marshalling key for deactivation of ACCELERATION TIMES:<br>Bit 2 = 0 (and bit 6 = 0): MN key as accel. deact.<br>Bit 2 = 1 (and bit 6 = 0): F4 as acceleration deactivation<br>Bit 6 = 1 (bit 2 irrelevant): F3 as acceleration deact.<br>Type (range of action) of key (MN, F3 or F4) for deactivating acceleration times:<br>Bits 1,0 = 00: no influence on acceleration times<br>= 10: reduces acceleration/deceleration time to ¼ of the values according to CVs #3, #4.<br>= 11: deactivates acceleration/deceleration time completely.<br><b>EXAMPLES:</b><br>F3 as half speed key, if CV #124 = 16<br>F3 as half speed key and<br>F4 to completely disable acceleration/deceleration time, if bits 0, 1, 2, 4 = 1, so CV #124 = 23<br>F3 as half-speed key and for Accel. deact. if bits 0, 1, 4, 6 = 1, i.e. CV #124 = 83<br>Bit 7 = 0: SUSI interface active (or servos, if defined in CVs #181, #182, ...<br>= 1: Logic level activated instead of SUSI. |
| 3.21 | #125 | Effects American lighting effects, and other effects, couplings, smoke generators, etc. on the FO   |                            | 0          | Bits 1, 0 = 00: bidirectional (active in both directions)<br>= 01: only active in forward direction<br>= 10: only active in reverse direction<br><b>ATTENTION</b> in case of CV #125 and #126: change CVs #33, #34.... if direction is wrong!<br>Bits 7, 6, 5, 4, 3, 2 = Effect-Code<br><b>EXAMPLES</b> (Effect - value programmed into CV #125)<br>Mars light, only forward - 00000101 = "5"  |

|              | CV                   | Denomination   | Range                         | Default     | Description  |
|--------------|----------------------|--|-------------------------------|-------------|--|
|              |                      | "Front light",<br>Configurations and modifications of the effects by CVs #62, #63, #64, and CV #115, #116 (for coupler).                                       |                               |             | Gyalrite, independent of direction - 00011100 = "28"<br>Ditch type 1 left, only forward - 00100101 = "37"<br>Uncoupler -00110000 = "48"<br><b>Soft start of output</b> -00110100 = "52"<br><b>Automatic Brake light</b> -00111000 = 56<br>Automatic Cab light OFF - 00111100 = "60"<br>Speed/load depen. Smoke - 01001000 = "72"<br>Speed/load depen. Diesel smoke - 01010000 = "80"   |
| 3.20         | #126                 | Effects on function output rear light  |                               | 0           | See CV #125 for details<br>#125 → Front headlight<br>#126 → Rear headlight   |
| 3.19<br>3.20 | #127 - #132          | Effects on FO1, FO2, FO3, FO4, FO5, FO6  |                               | 0           | See CV #125 for details<br>#127 → FO1 #128 → FO2<br>#129 → FO3 #130 → FO4<br>#131 → FO5 #132 → FO6   |
| 3.21<br>5.3  | #133                 | Using FO4 as Cam-sensor output for the module of your choice or<br>FO4 as output for Steam fan of the Smoke generator of steam locos<br><br>Reed configuration | Bit 0                         | 0           | = 0 (Default): FO4 is used as normal function output so it's controllable by function key instead of a cam sensor.<br>= 1: FO4 for smoke-fan which is usually controlled by a real or "virtual" cam sensor. Also see CVs #267, #268!<br><b>NOTE:</b> The fan operation is also determined by the sound project.<br><b>NOTE:</b> Large-scale decoders do have special outputs and additional configuration possibilities for smoke fans!<br>Bit 4 – inverts the polarity of Reed input 1<br>Bit 3 – inverts the polarity of Reed input 2<br>Bit 2 – inverts the polarity of Reed input 3<br>Bit 5 – inverts the polarity of Reed input 4<br>Bit 6 - (only types MS440) Pin IN4 becomes output FA9 |
|              | #134                 | Asymmetry stopp (ABC)  | 1 - 14                        | 6           | threshold (tens digit, ones digit).  |
| 3.24         | #136                 | Fine adjustment of the speed feedback or km/h - control no. calibration run  | RailCom Display factor        | 128         | RailCom speed feedback correction factor.<br>or (see chapter 5.8 in manual for small decoders) reading out the result of the internally computed speed after the calibration run.  |
| 3.21         | #137<br>#138<br>#139 | Definitions of smoke generator characteristic, connected to FO1 – 6.<br><br>PWM at stand still<br>PWM at steady speed<br>PWM during accel.                     | 0 - 255<br>0 - 255<br>0 - 255 | 0<br>0<br>0 | This is valid, if in one of the CVs #127 - #132 has set on of the function effects "smoke generation" (i.e. "72" or "80"): The values in CVs #137 – #139 define a characteristic for the function outputs (FO1 - FO8; referred to below as FOx).<br>CV #137: PWM of FOx at standstill<br>CV #138: PWM of FOx at steady speed<br>CV #139: PWM of FOx at acceleration  |



|      | CV   | Denomination   | Range                  | Default | Description   |
|------|------|--|------------------------|---------|---|
| 3.12 | #140 | Distance controlled stopping - Constant Braking Distance<br>Selection of the braking occasion and the braking behavior | 0, 1, 2, 3, 11, 12, 13 | 0       | Activation of distance-controlled stopping (Constant Braking Distance) as defined in CV #141 instead of time controlled braking as defined in CV #4, for = 1 automatic stop with ZIMO HLU ("signal-controlled speed influence") or ABC (signal stop by "asymmetric DCC signal").<br>= 2 manual stop by speed controller.<br>= 3 automatic and manual stopping.<br>In the above cases (= 1, 2, 3) braking from partial speeds is delayed so that the train does not "creep" for an unnecessarily long time (this is the recommended choice).<br>On the other hand<br>= 11, 12, 13 as above, but braking is always initiated as soon as the train is entering the stopping section. |
| 3.12 | #141 | Distance controlled stopping - Constant Braking Distance<br>The braking distance                                       | 0 - 255                | 0       | The value in this CV defines the "Constant Braking Distance". The value suitable for the existing braking distances must be determined by trial and error; as a guide can serve: CV #141 = 255 means approx. 500 m in the prototype (i.e. 6 m in H0), CV #141 = 50 is approx. 100 m (i.e. 1.2 m for H0).<br>see also: CV #831 - #833  |
| 3.12 | #830 | Braking distance forward High Byte   | 0 - 255                | 0       | Extended definition of the Constant Braking Distance: With CV #830 - #833 a more precise and direction dependent braking distance can now be set. The factor compared to CV #141 is 1 to 16.<br><br>The braking distance to be defined is calculated from: (256 * High Byte) + Low Byte.<br>CVs #830 - #833 are only effective if CV #141 = 0.  |
| 3.12 | #831 | Braking distance forward Low Byte  | 0 - 255                | 0       |   |
| 3.12 | #832 | Braking distance backward High Byte  | 0 - 255                | 0       |   |
| 3.12 | #833 | Braking distance backward Low Byte   | 0 - 255                | 0       |   |
| 3.12 | #143 | Distance controlled stopping - Constant Braking Distance<br>Compensation for HLU method                                | 0 - 255                | 0       | Since HLU is more error-resistant than ABC, no detection delay is usually necessary; therefore default 0.   |
| 3.7  | #146 | Compensation for gear backlash during direction changes in order to prevent start-up jolt.                             | 0 - 255                | 0       | = 0: no effect<br>= 1 to 255: in case the driving direction was changed beforehand, the motor spins at minimum rpm for a defined timespan (according to CV #2) for a specific time and only starts to accelerate after this time has elapsed.<br>The time of these "idle rotations" can only be tried; typical values:<br>= 100: the motor turns about 1 revolution or a maximum of 1 second at the minimum speed.<br>= 50: about 1/2 a turn or max. 1/2 second.<br>= 200: about 2 turns or max. 2 seconds.<br>Important: The minimum speed in CV #2 must be configured correctly, so that the train moves perfectly at the   |

|            | CV                   | Denomination   | Range                                       | Default          | Description  |
|------------|----------------------|--|---|------------------|--|
|            |                      |  |   |                  | lowest speed step (1).   |
| 3.6        | #147<br>#148<br>#149 | Fine adjustment of the PID parameters<br><b>NOTE:</b> are adjusted automatically with CV #56!                          | 0 - 255<br>0 - 255<br>0 - 255               | 100<br>10<br>100 | Integral value of the PID-motor regulation, recommended for „modern“ powertrain: CV #147 = 65<br>Differential value of the PID-motor regulation, recommended for „modern“ powertrain: CV #148 = 45<br>Proportional value of the PID-motor regulation, recommended for „modern“ powertrain: CV #149 = 65  |
| 3.4<br>3.6 | #151                 | Reduction of motor control in consist operation<br><br>or<br><br>motor brake (if address NOT in consist)               | Tens digit<br>1 - 9                         | 0                | The tens digit reduces the motor compensation to 10% - 90% according to the value in CV #58.<br>= 0: brake not active<br>= 1 - 9: In case of "zero power supply to the motor" (Motor PWM = 0) the speed to the desired speed step is still not reached (speed is still too high), the motor brake is slowly activated (distributed to 1, 2, ... 8 seconds until the full effect by short circuit on the motor through the power amplifier). The higher the value, the stronger the brake is applied.<br>= tens digit (1-9): Reduction of the motor regulation if consist-key is active. The values 1 - 9 in the tens digits in CV #151 reduce the control to 10% - 90% of the value set in CV #58. |
| 3.19       | #152                 | Dim Mask 2<br>Excludes specific function outputs from dimming<br>Addition to CV #114 and FO3, FO4 as Direction outputs | Bits<br>0 - 5<br><br>and<br>Bit 6,<br>Bit 7 | 0<br><br>0       | ... Addition to CV #114.<br>Bit 0 - function output FO7,<br>Bit 1 - function output FO8,<br>Bit 2 - function output FO9,<br>Bit 3 - function output FO10,<br>Bit 4 - function output FO11,<br>Bit 5 - function output FO12.<br>Bit 6 = 0: "normal"<br>= 1: Direction bits on FO3, FO4, i.e. FO3 is switched on when driving backwards, FO4 is switched on when driving forward.<br>(for Märklin switch type C)<br>Bit 7 = 1: direction bit for FO9 when driving forward  |
| 3.1        | #153                 | Time limit for continued driving without rail signal   | 0 - 255                                     | 0                | 0: Feature not used<br>1 - 255: Time in tenths of a second after which the decoder starts a braking process if there is no more DCC reception via its two track contacts.<br>During the braking process all braking CVs (e.g. CV #4) are considered. Common CV values for CV #153 are either 0 or 10-20 (for 1.0 to 2.0 seconds).  |
| 5.4<br>5.6 | #154                 | Various special bits   |   | 16               | Bit 1 = 1: DIESEL, ELECTRO Drive off immediately even if playback of idle sound has not yet finished.<br>Bit 2 = 1: DIESEL, ELECTRO After short stops, wait for idle sound before driving off.<br>Bit 4 = 1: STEAM: Two stage compressor (Z1 for fast refill after coming to a stop, Z2 for slow pressure loss compensation during longer stops).<br>Bit 7 = 1: Delay start until playback of start-up whistle has finished.<br>Other bits: OEM special applications (i.e. Panto control etc.)   |
| 3.13       | #155                 | to be preferred for new projects alternative to CV   | 0,<br>1 - 28,<br>29,                        | 0                | In extension of the settings of CV #124, if the selection there (half speed on F3 or F7) is not sufficient, because another key is desired:  |



|            | CV   | Denomination  | Range  | Default | Description   |
|------------|------|---|--|---------|---|
|            |      | #124:<br>Selecting a function key for half speed  | 30<br>and bits 7, 6, 5 for Setting Half-speed.               |         | CV #155: Determination of the function key, with which the half speed (= highest speed step results in half speed) can be switched on.<br>If CV #155 > 0 (i.e. a key is set), a possible assignment in CV #124 is ineffective.<br>If CV #155 =<br>= 0: CV #155 is not active, so CV #124 is valid.<br>= 1 - 28: Function key F1 - F28<br>= 29: Function key F0<br>= 30: MAN key<br>Bits 7, 6, 5: Modification of the "half" speed".<br>= 000: Speed according to speed step, multiplied by 0.625<br>= 001 ... 100: ... speed step, multiplied by 0.125 ...0.5<br>= 100 ... 111: ... speed step, multiplied by 0.5 ...0.875  |
| 3.13       | #156 | to be preferred for new projects alternative to CV #124:<br><br>Selecting a function key for deactivating momentum        | 0,<br>1 - 28,<br>29,<br>30,<br><br>129 - 156,<br>157,<br>158 | 0       | This CV overwrites the setting of the F keys in CV #124 (bit 2&6) in case it is not satisfactory. The set range (bit 0&1) of the acceleration behavior does not change.<br>If CV #156 > 0 (i.e. a key is set), any assignment in CV #124 is ineffective.<br>If CV #155 =<br>= 0 means CV #155 is not active, so CV #124 is valid.<br>= 1 - 28: Function key F1 - F28<br>= 29: Function key F0<br>= 30: MAN key<br>Bit 7 = 1: Suppression of switching the light when reversing direction.<br>The settings of CV #124 about the type of deactivation or reduction still apply, thus:<br>CV #124, Bit 1, 0 =<br>= 00: no influence on acceleration times<br>= 10: reduces acceleration/deceleration time to ¼ of the values according to CVs #3, #4.<br>= 11: deactivates acceleration/deceleration time completely.<br>Typically, CV #124 = 3 is set to achieve full deactivation (unless other bits in CV #124 are also set). |
| 3.13       | #157 | Selection of a Function key for the MAN-function<br><br>Only for non-ZIMO controllers that don't have a dedicated MN key. | 0 - 19   | 0       | The MAN function (or MAN key on ZIMO controllers) was originally designed for ZIMO applications only, in order to cancel stop and speed limit commands applied by the "signal-controlled speed influence" system (HLU).<br>This function was expanded in later software versions to include "asymmetrical DCC signal stops" (Lenz ABC).<br>If ZIMO decoders are used with non-ZIMO systems which do not have this key (rarely with HLU, usually with ABC), a function key can now be assigned with CV #157 to cancel a signal-controlled speed limit or stop command.   |
| 5.4<br>5.6 | #158 | Various special bits<br>Bits 1, 3, 5, 6, 7<br>(only Diesel & Electro)   |  | -       | Bit 1 = 1: Diesel mechanical: RPM is not raised when braking (see CV #364).<br>Bit 2 = 0: RailCom speed feedback (km/h) feedback in "old" format (for MX31ZL, RailCom ID 4)<br>= 1: RailCom speed feedback (km/h) Normal feedback (RailCom ID 7)<br>Bit 3 = 1: (DIESEL) Sample for standstill is faded out when driving-off "early".  |

|              | CV                                  | Denomination  | Range  | Default                     | Description  |
|--------------|-------------------------------------|---|--|-----------------------------|--|
|              |                                     |   |  |                             | Bit 4 = 1: Steam chuff frequency increases slower at high speed (non-proportional)<br>Bit 5 = 1: (DIESEL) Braking (even by one speed step) causes the motor and turbo sounds to decrease by on sound step.<br>Bit 6 = 1: (ELECTRIC) Thyristor sound may be louder when braking.<br>Bit 7 = 1: (ELECTRIC) Switchgear sparks on FO7.   |
| 3.19<br>3.20 | #159<br>#160                        | Effects on FO7, FO8   |  | 0                           | like CV #125 #159 → FO7 #160 → FO8   |
| 3.25         | #161                                | Servo outputs: Protocol and alternate Use of Servo outputs: 3 & 4 as SUSI pins    | 0 - 3<br><b>NOTE:</b><br>For Smart Servo RC-1 set CV #161 = 2! | 0                           | Bit 0 = 0: Servo protocol with positive pulses.<br>= 1: Servo protocol with negative pulses.<br>Bit 1 = 0: Control wire only active during movement<br>= 1: ... always active (draws current, judders sometimes but holds the position also at mechanical load);<br>Bit 2 = 0: For two-key operation (as per CV #181, ...) with center position, if none of the two keys is activated.<br>= 1: For two-key operation (as per CV #181, ...), where the servo runs only as long as function keys are active. |
| 3.25         | #162                                | Servo 1 Left position   | 0 - 255  | 49<br>= 1 ms<br>Servo pulse | Defines the servo's left stop position. "Left" may become the right stop, depending on values used.  |
| 3.25         | #163                                | Servo 1 - Right stop  | 0 - 255  | 205                         | Defines the servo's left stop position.  |
| 3.25         | #164                                | Servo 1 Center position   | 0 - 255  | 127                         | Defines a center position, if three positions are used.  |
| 3.25         | #165                                | Servo 1 Rotating speed  | 0 - 255  | 30<br>= 3 sec               | Rotating speed; time between defined end stops in tenths of a second (total range of 25 sec, default 3 sec.).  |
| 3.25         | #166 - #170<br>#173<br>#174<br>#177 | Same as input mapping above for other functions:<br>servo 2<br>servo 3<br>servo 4 |  |                             |  |
| 3.25         | #178                                | Panto Reverberation   | 0 - 255  | 0                           | Valid for each servo, which is "Panto..." under CVs #181 - #184 (function assignments) = 94 - 97),<br>After reaching the final position (i.e. after "Panto lift") the Panto should move slightly up and down a few more times. CV #178 sets the amplitude of this oscillation (more precisely the first one)<br>= 0: no oscillation<br>= 50: sensible initial setting, vary from there.  |
| 3.25         | #181<br>#182<br>#183<br>#184        | Servo 1<br>Servo 2<br>Servo 3<br>Servo 4  | 0 - 28<br><br>90 - 97  | 0<br>0<br>0<br>0            | = 0: Servo not in operation<br>= 1: Single-key operation with F1<br>= 2: Single-key operation with F2<br>and so on..<br>= 28: Single-key operation with F28  |



|      | CV                           | Denomination   | Range                         | Default | Description   |
|------|------------------------------|--|-------------------------------|---------|---|
|      |                              | Function assignment<br><br><b>NOTE:</b><br>If a servo control line shares its connection with another function (e.g. SUSI or input) for optional use, a value >0 in CV #181, #182, ... means switching to servo control line. This concerns with "small" decoders (track N ... H0) the "official" SUSI pins, which are switched to servo with CVs #181, #182 (SUSI no longer present), with MS950, MS955 servos 3 + 4, with MS990 7 + 8. | 101-114<br><br>201 -208       |         | = 90: Servo dependent on loco direction forward = servo left; reverse = servo right<br>= 91: Servo dependent on loco direction and standstill i.e. Servo on the right at standstill and direction forward, otherwise servo on the left<br>= 92: Servo dependent on loco direction and standstill i.e. Servo on the right at standstill and direction backwards, otherwise servo on the left<br>= 93: Servo dependent on standstill or cruising i.e. Servo on the right at standstill, servo on the left at cruising; direction without effect.<br>= 94: refers to function "Panto1" which is configured in CV #186.<br>= 95: ... "Panto2" configured in CV #187<br>= 96: ... "Panto3" configured in CV #188<br>= 97: ... "Panto4" configured in CV #189<br>= 101: Two-key operation F1 + F2<br>= 102: Two-key operation F2 + F3 and so on..<br>= 111: Two-key operation F11 + F12<br>= 112: Two-key operation F3 + F6<br>= 113: Two-key operation F4 + F7<br>= 114: Two-key operation F5 + F8<br>(Two-key mode as defined with CV #161, Bit 2)<br>= 201 - 208: Events 1 - 8 from scripts or sound |
| 3.25 | #185                         | Special assignment for live steam engines  |                               | 0       | = 1: Steam loco with one servo in operation; Speed and direction of travel by slider, center position means stop.<br>= 2: Servo 1 proportional on speed regulator Servo 2 for direction.<br>= 3: like 2, however: Direction-servo is automatically in "neutral" if speed is 0 and F1 = ON;<br>At speed step > 0:<br>If direction-servo is engaged.<br><b>NOTE</b> to CV #185 = 2 or 3:<br>Servo 1 is adjustable with CV #162, #163 (end-positions), by using the corresponding values, it is also possible to change the direction.<br>Servo 2 is adjustable with CV #166, #167.  |
| 3.25 | #186<br>#187<br>#188<br>#189 | "Panto1"<br>"Panto2"<br>"Panto3"<br>"Panto4"   |                               | 0       | Bit 7 = 0: Not sound-dependent<br>= 1: Sound-dependent<br>Bit 6 - 5 = 00: direction independent,<br>= 01: only if loco drives forward<br>= 10: only if loco drives backwards<br>= 11: only if F-key is turned off<br>Bit 4 - 0: to Activate<br>00001 = F1 00010 = F2 00011 = F3, ...  |
| 3.21 | #190                         | Brightening-up time for effects 88, 89 and 90  | 0 - 100<br>101-200<br>201-255 | 0       | The range 0 -100 corresponds to 0 - 1 sec (10ms/value)<br>101 - 200 1 - 100s (1s/value)<br>201 - 255 100 - 320s (4s/value)  |
| 3.21 | #191                         | Dimming time for effects 88, 89 and 90   | 0 - 100<br>101-200<br>201-255 | 0       | The range 0 - 100 corresponds to 0 - 1 sec (10ms/value)<br>101 - 200 1 - 100s (1s/value)<br>201 - 255 100 - 320s (4s/value)   |
|      | #192                         | Value for effect dimming   | 0 - 255                       | 0       | Code 011010xx in CV #125ff: Decreases the brightness of the (light) function output by the set value (in percent). (e.g. value 127 = 50 %)  |

|  | CV   | Denomination          | Range  | Default                     | Description |  |
|--|------|-----------------------|--|-----------------------------|-------------|--|
|  | 0    | #193                  | ABC - commuting with stopping times in reverse loops   | 0,<br>1 - 255               | 0           | = 0: no commuting on ABC basis<br>= 1 - 255: Stopping period (in sec) in the ABC stopping (=turnaround) sections at the end of the commuting distance.   |
|  | 0    | #194                  | ABC - commuting with additional stopovers  | 0,<br>1 - 254,<br>255       | 0           | Only as commuting if CV #193 = 1 - 255<br>= 0: Commuting without stopovers (see above)<br>= 1 - 254: Commuting with stopovers (terminal loops by ABC slow-speed sections, stopovers defined by ABC stopping sections)<br>Stopping period (in sec) in the stopovers<br>= 255: as above but permanent stop in stopovers (until stop is cancelled).   |
|  | 3.21 | #195 - #199           | Effects on FA9, FA10, FA11, FA12, FA13   |                             | 0           | like CV #125 #195 → FO9 #196 → FO10<br>#197 → FO11 #198 → FO12<br>#199 → FO13  |
|  | 3.24 | #201                  | Alternative (clearer, preferred for new projects) "SUSI" usage   | 0, 11,<br>22, 33, 44,<br>55 | 0           | = 11: SUSI pins as logic level outputs (see above)<br>= 22: SUSI pins as reed inputs<br>= 33: SUSI pins as servo control lines<br>= 44: SUSI pins as "SUSI pins" (same as 0)<br>= 55: SUSI pins as I2C bus.  |
|  | 3.24 | #202                  | If decoder (large scale decoder) has two "SUSI" connections  | 0, 11,<br>22, 33, 44,<br>55 | 0           | As above (CV #201), but for second SUSI connection; there, however, CV #202 is the only setting option, not just the alternative).   |
|  | 3.24 | #203, #204            | Use of the inputs IN1 & IN2, or IN3 & IN4  | Ones and tens 0, 1, 2, 4    | 0           | = 11: both "IN"s as logic level outputs (see above)<br>= 22: both "IN"s as logic level ("reed") inputs<br>= 44: both "IN"s as input for axis detector<br>CV #203 ones digit: IN1, tens digit: IN2<br>CV #204 ones digit: IN3, tens digit: IN4<br>If the axis detector is used but neither CV #203 nor #204 is configured, then IN3 is taken as default.  |
|  | 3.3  | #248 #249             | Bootloader version and subversion  | Read only                   | -           | Reading out these CVs provides the version and subversion of the bootloader currently on the decoder (bootloader = program to load the actual software).   |
|  | 3.2  | #250 #251 #252, #253  | Decoder-ID,, thereof CV #250 and CV #251 (Bits 7- 4) = Decoder-Type (See chapter 2 Technical Data, schematics, operation with mfx...) CV #251 (Bits 3 - 0) and CV #252 + #253 = serial no. | Read only                   | -           | The decoder ID (serial number) is automatically entered during production: The first byte and half of the second byte denotes the decoder type; the rest contain a serial number.<br>The decoder ID is primarily used for automatic address assignment when an engine is placed on the layout track as well as in combination with the "load code" for "coded" sound projects (see CVs #260 - #263). |
|  | 3.2  | #260 #261, #262, #263 | "Load code" for "coded" sound projects   | -                           | -           | New ZIMO sound decoders can be ordered for an additional small fee with a "load code" pre-installed, which entitles the user to install "coded" sound projects of a selected sound bundle. The load code can also be purchased and installed by the user later: see <a href="http://www.zimo.at">www.zimo.at</a> .   |
|  | 3.26 | #264                  | Variable low voltage (large scale and special decoders)  | 10 - 158                    | 15          | Variable low voltage (adjustable by CV, only large scale and some special decoders)<br>= 10 - 158: Low voltage in tenths of a volt (1 - 15.8 V)  |



|     | CV   | Denomination   | Range                              | Default   | Description  |
|-----|------|--|------------------------------------|---|--|
| 5   | #265 | Selection of Loco type   | 1<br>2<br>...<br>101<br>102<br>... | 1 or 101<br>Type of steam loco<br>1 or 101<br>Diesel loco | = 0, 100, 200: Reserved for future applications<br>= 1 - 32: Selection of sounds of steam locos in Sound Collection, e.g. for loco type BR01, BR28, BR50, etc. Sounds like chuff sounds as well as other sounds (whistle, compressor, bell...) will be matched.<br>= 101 - 132: Selection of diesel loco types (if several diesel sounds are in the collection).   |
| 5.3 | #266 | Total volume (Multiplier)  | 0 - 255<br>= 0 - 400 %             | 64<br>= 100 %   | The default value "64" results in the (mathematically) highest possible distortion-free playback volume; but values of up to 100 may nonetheless be practical. <b>Recommended: CV #266 = 40 - 90</b>   |
| 5.4 | #267 | Chuff beat frequency according to "virtual Cam sensor"<br><br>also see CV #354 in this table (Steam chuff Frequency at speed step 1)         | 0 - 255                            | 63  | CV #267 is only active if <b>CV #268 = 0</b> :<br>Chuff beats follow the "virtual cam sensor"; an actual cam sensor is not needed in this case.<br>The basic configuration "70" results in about 4 to 6 to 8 chuffs per rotation, depending on the selected chuff-set. Because it also depends in large part on the motor and gearbox used, an individual adjustment is necessary in most cases in order to achieve the exact chuff frequency; therefore, CV #267 is used:<br>The lower the value the higher the chuff frequency and vice versa. The setting should be performed at a low speed (around speed step 10), but not at the lowest speed step 1.<br>By means of CV #393 bit 6 = 1 the chuff interval of CV #267 can be extended 4 times.  |
| 5.4 | #268 | Switch to real cam sensor and<br>Number of spikes of the cam sensor for chuff beat and<br>Special functions "simple articulated" steam locos | 0 - 63<br><br>and<br>128, 192      | 1   | = 0: "Virtual" cam sensor is active (to be adjusted with CV #267, see above).<br>= 1: Real cam sensor (connected to „In2" resp. "In3" of the decoder) is active, each negative spike results in a chuff<br>= 2, 3, 4 ... 63 real cam sensor, several triggers in sequence (2, 3, ..., 63) result in one chuff beat.<br>= 128 (bit 7=1 with "virtual" cam sensor): second driver is a bit slower; only meaningful if a second sound sample is available in the sound project.<br>= 192 (bits 6 and 7 = 1): When no separate sound sample is available for the second driver, the same sample is played back for the second driver, only a bit slower.<br>Bit 7 = 1: with real cam sensor, see values above<br>Cam sensor for driver 1 at IN3 (as always),<br>Cam sensor for driver 2 at IN2,<br>(only possible if decoder has two inputs) |
| 5.4 | #269 | Lead-chuff-accentuation  | 0 - 255                            | 10  | A typical sound signature of a passing steam engine is that one chuff out of a group of 4 or 6 chuffs is louder in volume than the rest; this effect is already part of the chuff set but can be further amplified with the help of CV #269.   |
| 5.4 | #271 | Fast driving overlapping effect  | 0 - 255<br>(Useful up to @ 30)     | 1   | The individual steam chuffs of a real engine overlap each other at high speed. Because the frequency of the chuffs increases but won't shorten to the same extend, they will eventually blend in to a weakly modulated swoosh. This is not always desired in model railroading because it doesn't sound that attractive, hence CV #271, with which   |

|     | CV   | Denomination   | Range   | Default | Description   |
|-----|------|--|---------|---------|---|
|     |      |  |         |         | an adjustment is possible to have the chuff beats accentuated at high speed or rather fade away.  |
| 5.4 | #272 | Blow-off duration<br><br>also see CV #312 in this table (Blow off Key) |         |         | Opening the cylinder valves on a prototype steam engine for the purpose of water drainage is entirely up to the engineer. An automated draining at start-up is more suitable in model railroading; CV #272 defines how long after start-up the blow-off sound should play.<br>Value in CV #272 = time in tenths of a second!<br><b>NOTE:</b> If the blow-off sound is also allocated to a function key (as delivered on F4, see CV #312), the automated blow-off sound can be shortened or extended with the relevant function key. Automated blow-off and funct. key blow-off are inevitably the same (as per select./alloc.).<br><b>= 0:</b> no blow-off sound playback                       |
| 5.4 | #273 | Blow-off Start-up delay  |         |         | Opening the cylinder valves and with it the related blow-off sound on a real steam engine starts most often before the engine even starts to move. This can be imitated with CV #273 by automatically delaying the start of the loco. This effect is cancelled when a shunting function with momentum deactivation is being activated (see allocation of F3 or F4 in CV #124!)<br>= 0: no delayed start<br>= 1: Special setting blow-off by controller; no delayed start, however, lowest speed step (lowest slider position > 0, only for 128 speed steps) means "do not drive yet, but blow off!"<br>= 2 ... Start-up delay in tenths of seconds:<br>Recommendation: no values > 20 (> 2 sec) |
| 5.4 | #274 | Blow-off Standstill and Starting whistle Standstill                    |         |         | Constant opening and closing of the cylinder valves in real shunting operations, that often requires many short trips with associated idle times, is usually omitted. CV #274 causes the blow-off sound to be suppressed if the engine wasn't standing still for the time defined here.<br>Value in CV #274 = time in tenth of a second!<br>The same stop-time is also used for the start-up whistle!   |
| 5.5 | #275 | Chuff volume at low speed without load                                 | 0 - 255 | 220     | With this CV the chuff volume can be adjusted for low speed and "basic load" (same conditions as during the "automated recording run").<br>Here, the engine is driven by about 1/10 of its full speed, adhering to the exact speed is however not important. During this adjustment CV #277 is to be left at "0" (default), so that the setting for "no-load driving" is not influenced by load factors.  |
| 5.5 | #276 | volume at high speed without load                                      | 0 - 255 | 220     | Like CV #275 (see above) but for driving fast. Set the speed regulator to maximum during this set-up.   |
| 5.5 | #277 | Dependency of chuff volume of current load                             | 0 - 255 | 10      | When deviating from the basic load (as determined by the "Automated recording of the motor's "basic load" factor", see above), the chuff beat volume should be increasing (on inclines) or decreasing on declines (even muted).<br>CV #277 defines the degree of dependency; the proper value has to be set by trial.   |
| 5.5 | #278 | Load changing  | 0 - 255 | 10      | With this CV, a change in volume in reaction to small   |



|     | CV   | Denomination   | Range                             | Default | Description   |
|-----|------|--|-----------------------------------|---------|---|
|     |      | threshold  |                                   |         | load changes can be suppressed (i.e. in curves) in order to prevent chaotic sound impressions. Suitable settings can only be determined by trial.   |
| 5.5 | #279 | Load changing delay  | 0 - 255                           | 1       | This CV determines how quick the sound reacts to load changes, whereas the factor is not just time but rather "load-change dependent time" (= the bigger the change the faster the effect). This CV is also used to suppress chaotic sound changes. Suitable settings can only be determined by trial.  |
| 5.6 | #280 | Diesel engine - Load dependency                                    | 0 - 255                           | 10      | With this setting, the diesel motor's reaction to the load (defined by PWM and speed step). <b>NOTE:</b> the sound of the diesel motor practically always depends on acceleration and speed.<br>Diesel-hydraulic loco - higher and lower PWM and performance steps,<br>Diesel-electric loco - driving/idle<br>Loco with switchgear - steps.<br>= 0: no influence motor PWM according to speed<br>= 1 to 255: increasing to maximum influence<br><b>NOTE:</b> It is recommended, first to perform the <b>automated test run</b> with CV #302 = 75 first (see chapter 5.3). |
| 5.5 | #283 | Driving noise- (Steam chuffs) Volume - for full acceleration sound | 0 - 255                           | 255     | The volume of steam chuffs at maximum acceleration is set with CV #283 (default: 255 = full volume). If CV #281 = 1 (acceleration threshold set to 1 speed step), the volume defined here is applied with each speed increase, even if it is just 1 step.   |
| 5.5 | #284 | Deceleration threshold for reduced volume during deceleration      | 0 - 255<br>(Internal Speed steps) | 1       | Steam chuffs should be played back at less volume (or muted) signifying the reduced power requirement during deceleration. The sound reduction logic is analog to a reversed acceleration (per CV #281 to #283).<br>= 1: Reduces sound to a minimum (as per CV #286) when speed is reduced by just 1 step.<br>= 2, 3 ... sound reduced to minimum after lowering speed by this number of steps.   |
| 5.5 | #285 | Time needed for the volume reduction at deceleration               | 0 - 255<br>=<br>0 - 25 sec        | 30      | After the speed has been reduced, the sound should remain quieter for a specific time (analog to the acceleration case).<br>Value in CV #285 = time in tenth of a second!   |
| 5.5 | #286 | Volume - of reduced driving noise- at deceleration                 | 0 - 255                           | 20      | CV #286 is used to define the chuff volume during deceleration (default: 20 = pretty quiet but not muted). If CV #284 = 1 (deceleration threshold set to 1 speed step), the volume defined here is applied with every reduction in speed (even if decreased by just 1 step).  |
| 5.3 | #287 | Threshold for brake squeal   | 0 - 255                           | 50      | The brake squeal should start when the speed drops below a specific speed step. It will be automatically stopped at speed 0 (based on back-EMF results).  |
| 5.3 | #288 | Brake squeal minimum drive time                                    | 0 - 255<br>=<br>0 - 25 sec        | 50      | The braking squeal is to be suppressed when an engine is driven for a short time only, which is usually a shunting run and often without any cars (it is mostly the cars that are squealing not the loco itself!).<br><b>NOTE:</b> Brake squeal sounds can also be assigned to a function key (see allocation procedure CV #300 = ...), with which the brake squeal can be started or stopped   |

|     | CV   | Denomination                                      | Range     | Default | Description   |
|-----|------|---|-----------|---------|---|
|     |      |   |           |         | manually!   |
| 5.6 | #289 | Thyristor Step-effect                             | 0 - 255   |         | = 1 - 255: Effect of pitch  |
| 5.6 | #290 | Thyristor sound pitch: "slow" pitch increase      | 0 - 255   | 50      | Sound pitch for speed defined in CV #292.   |
| 5.6 | #291 | Thyristor sound pitch: Maximum pitch              | 0 - 255   | 255     | Sound pitch at top speed.   |
| 5.6 | #292 | Thyristor sound pitch: slow speed                 | 0 - 255   | 128     | Speed for sound pitch per CV #290.  |
| 5.6 | #293 | Thyristor sound pitch: Steady volume              | 0 - 255   | 100     | Thyristor sound volume at steady speed (no acceleration or deceleration in progress).   |
| 5.6 | #294 | Thyristor sound pitch: Vol. at acceleration       | 0 - 255   |         | Volume during acceleration  |
| 5.6 | #295 | Thyristor sound pitch: Vol. at deceleration       | 0 - 255   |         | Volume during heavier decelerations (braking)   |
| 5.6 | #296 | Electric motor Volume                             | 0 - 255   | 0       | Motor sound volume.   |
| 5.6 | #297 | Electric motor Minimum load                       | 0 - 255   | 0       | Internal speed step at which the motor sound becomes audible; at this speed step is starts at a low volume and reaches maximum volume as per CV #296 at the speed step define in CV #298.   |
| 5.6 | #298 | Electric motor Volume - Speed dependency          | 0 - 255   | 0       | Internal speed step at which the motor sound reaches the maximum volume defined in CV #296.<br>See ZSP manual!  |
| 5.6 | #299 | Electric motor Pitch (frequency) Speed dependency | 0 - 100   | 0       | The motor sound will be played back faster, corresponding to this CV with rising speed.<br>= 0: Pitch (speed of play back) will not rise<br>= 100: Doubling the pitch   |
| 5.3 | #307 | Cornering squeals-order Reed configuration        |           |         | Bit0 - switching input 1 activates cornering squeal<br>Bit1 - switching input 2 activates braking squeal<br>Bit2 - switching input 3 activates braking squeal<br>Bit3 - switching input 4 activates braking squeal<br>Bit 7 - 0 = key defined in CV #308 suppresses cornering squeal of reed inputs if this key is ON<br>1 = key defined in CV #308 activates cornering squeal independent of Reed inputs |
| 5.3 | #308 | cornering squeal key                              | 0 - 28    | 25      | 0: No key defined. Reed inputs always active.<br>1-28 = key F1 to F28.  |
| 3.7 | #309 | Brake key   | 0, 1 - 29 | 0       | The key defined here acts as a brake key according to the rate defined in CV #349 (the normal - higher - deceleration time in CV #4 is thereby ignored). 0=deactivated; 1=F1, ..., 28=F28, 29=F0;   |





|            | CV                   | Denomination  | Range                         | Default       | Description   |
|------------|----------------------|---|-------------------------------|---------------|---|
| 5.3        | #310                 | ON/OFF key for Driving sound volume and Random Sounds | 0 - 28, 255                   | 1             | Function key to turn ON/OFF driving sounds (steam chuffs, boiling, blow-off, brake squeal, or diesel motor, thyristor sounds, etc.) as well as random sounds (air brake pump, coal shoveling, ...).<br>= 8: F8 key switches driving sound ON or OFF.<br><b>NOTE:</b> this is the default key for ZIMO original sound projects; typical OEM projects (i.e. ROCCO) often use other settings. Mostly 1 for the F1 key.<br>= 0 - 28 F0 - F28 as ON/OFF-key for driving noise.<br>= 255: Engine and random sounds are always ON. |
| 5.3        | #311                 | ON/OFF key for Function sounds                        | 0 - 28                        | 0             | Function key assigned as ON/OFF key of function sounds (i.e. F2 – whistle).<br>= 0: <b>does not mean</b> that F0 is assigned for this task but rather that the function sounds are always active (cannot be turned off).<br>= if the same value is entered here as in CV #310, the key defined in #310 turns all sound ON/OFF.<br>= 1 - 28: Separate ON/OFF key for function sound.   |
| 5.3<br>5.4 | #312                 | Blow-off key  | 0 - 28                        | 13            | See chapter 5.4 SOUND: Steam engine → sound basic configuration   |
| 5.3        | #313                 | "Mute key" fade in/out time Key                       | 0 - 28<br>101 - 128           | 114           | This CV assigns a function key with which the driving sounds can be faded in and out, i.e. when the train disappears behind scenery. In many sound projects, CV #313 = CV #310, i.e. the same value in both CVs, therefore all sounds are faded in/out.<br>= 0: No mute key or mute function.<br>= 1 - 28: Corresponding function key F1 - F28.<br>= 101 - 128: Assigned function key with inverted action.   |
| 5.3        | #314                 | Mute – fade in/out time                               | 0 - 255<br>=<br>0 - 25 sec    | 0             | Time in tenths of a second for sound fading in/out when mute button is pressed. Total range is 25 seconds.<br>= 0 (to 10): Minimum 1 sec<br>= 11 - 255: longer time until sound is muted  |
| 5.8        | #315                 | Random generator Z1 Minimal interval                  | 0 - 255<br>=<br>0 - 255 sec   | 1             | The random generator generates internal pulses in irregular intervals that are used to playback a sound file assigned to the random generator. CV #315 defines the shortest possible interval between two consecutive pulses.<br>Sound samples are assigned to the random generator Z1 with the help of the CV #300 = 101 procedure, see above! By default, the compressor is assigned to Z1.   |
| 5.8        | #316                 | Random generator Z1 Highest interval                  | 0 - 255<br>=<br>0 - 255 sec   | 60            | CV #316 defines the maximum time interval between two consecutive pulses of the random generator Z1; the actually occurring pulses between the values in CV #315 and #316 are equally distributed.  |
| 5.8        | #317                 | Random generator Z1 Duration of playback              | 0 - 255<br>=<br>0 - 255 sec   | 5             | The sound sample assigned to the random generator Z1 (most often the compressor) is played back for the timespan defined in CV #317.<br>= 0: Play back sound sample for the first time  |
| 5.8        | #318<br>#319<br>#320 | As above, however... Random generator Z2              | 0 - 255<br>0 - 255<br>0 - 255 | 20<br>80<br>5 | By default, Z2 is assigned for coal shoveling at stand-still.   |
| 5.8        | #321                 | As above,   | 0 - 255                       | 30            | By default, Z3 is assigned for the injector at stand-still.   |

|                   | CV                | Denomination  | Range                         | Default | Description  |
|-------------------|-------------------|---|-------------------------------|---------|--|
|                   | #322<br>#323      | however... Random generator Z3  | 0 - 255<br>0 - 255            | 90<br>3 |  |
| 5.8               | #324<br>-<br>#338 | As above, however... random generator Z4 - Z8   | 0 - 255<br>0 - 255<br>0 - 255 |         | At delivery this random generator is not used.   |
| 5.7               | #339              | Key for raising of diesel sound step  | 0 - 28                        | 0       | Function key that raises the diesel sound to the minimum speed defined with CV #340.<br>See below if more keys for further speed raises are required.  |
| 5.7               | #340              | Diesel sound step, to which is to be raised, and possibly more keys.  | 0 - 10                        | 0       | The minimum diesel step the sound is to be raised to with the function key defined with CV #339. This CV can be extended (to include more function keys by applying the formula): Minimum speed step + (16 * (Number of keys - 1))   |
| 5.8               | #341              | Switch input 1 Duration of playback   | 0 - 255<br>=<br>0 - 255 sec   | 0       | The sound sample allocated to switch input 1 is played back for the duration defined with this CV.<br>= 0: Play back sound sample for the first time   |
| 5.8               | #342              | Switch input 2 Duration of playback   | 0 - 255<br>=<br>0 - 255 sec   | 0       | The sound sample allocated to switch input 2 is played back for the duration defined with this CV.<br>= 0: Play back sound sample for the first time   |
| 5.8               | #343              | Switch input 3 Duration of playback   | 0 - 255<br>=<br>0 - 255 sec   | 0       | The sound sample allocated to switch input 3 (as far as it is not used as cam sensor) is played back for the duration defined with this CV.<br>= 0: Play back sound sample for the first time  |
| 5.6               | #344              | Run time of Motor sounds (Cooling fan, etc.) after stops  | 0 - 255<br>=<br>0 - 25 sec    |         | After the engine comes to a stop, some accessories are supposed to remain operating (e.g. cooling fans) and automatically stop after the time defined here, provided the engine didn't start up again.<br>= 0: Won't run after stop<br>= 1 - 255: Runs for another 1 to 25 seconds.  |
| 5.3<br>5.6        | #345              | Switch key to next sound variation within a sound collection for different operating modes of a locomotive or between the sounds of a multi-system engine | 0 - 28                        | 0       | Defines a function key (F1 – F28) which switches between two sound types that is, between the selected sound in CV #265 and the next one in the list.<br>For example:<br>- Switch between two modes of operation (light train / heavy train) or<br>- Switch between electric and diesel propulsion of a multi-system engine; typical case:<br>Sound project for RhB Gem. |
| 5.35.6            | #346              | Conditions for switching between collections, as per CV #345  | 0 – 2                         | 0       | Bit 0 = 1: Switches also at stand-still,<br>Bit 1 = 1: Switches also while cruising (bits for standstill and cruising possible at the same time)<br>Bit 6 = 1: Transition sets in diesel projects, which are played back when switching from one set to another.   |
| 3.7<br>5.3<br>5.6 | #347              | Key to switch key for driving and sound performance when  | 0 - 28                        |         | 0=: no key, no solo drive<br>= 1 - 28: One function key (F1 – F28) acts as the switch-over key for driving a heavy train or a single locomotive.   |



|                   | CV   | Denomination   | Range                      | Default | Description   |
|-------------------|------|--|----------------------------|---------|---|
|                   |      | driving solo   |                            |         |   |
| 3.7<br>5.3<br>5.6 | #348 | If the key for solo drive (CV #347, see above) is activated, the measures defined here have to be met.<br>Bit 2 already in version 4.10<br>Bits 0, 3, 4 (only Diesel): | 0 - 31                     |         | When driving solo (function key as per CV #347 is ON):<br>Bit 0 = 1: ... Diesel sound (sound steps) should rev up unlimited to maximum rpm (or limited in relation to speed step as per CV #389).<br>Bit 1 = 1: acceleration and deceleration times should be reduced according to CV #3 / #4, but consider the reduction according to CV #390.<br>Bit 2 = 1: motor's idle sound should be played back when driving at low speeds, whereas the highest speed step shall still be playing the idle sound set in CV #391.<br>Bit 3 = 1: deactivate 2nd smoke fan and heating element with this key (diesel loco with two engines only drives with one).<br>Bit 4 = 1: Suppress brake squeal |
| 3.7               | #349 | Braking time for brake key   | 0 - 255                    | 0       | To achieve the desired effect, the deceleration time in CV #4 must be set to a very high value (@ 50 - 250) but the brake time in CV #349 rather low (5 - 20). This simulates a coasting effect with the "regulator at 0", while the brake key results in a short stopping distance.  |
| 5.6               | #350 | Electric switch gear sound, locked after starting  | 0 - 255                    | 0       | Time in tenth of seconds (0-25 sec), the switchgear sound shall not be played back after starting; this is useful if the first switching step is already in the sample "Stand -> F1".<br>= 0: Switchgear is played back immediately after starting.   |
| 3.22              | #351 | Speed of the smoke fan at constant speed for DIESEL locomotives  | 1 - 255                    | 128     | The speed of the fan is set by PWM; the value of CV #351 defines the behaviour during normal driving.<br>= 128: Half voltage (PWM) when driving.  |
| 3.22              | #352 | Speed of the smoke fan during acceleration and engine starting for DIESEL locomotives  | 1 - 255                    | 255     | To create a cloud of smoke when starting the machines, the fan is set to higher (usually maximum) speed, as well as in case of strong acceleration during operation.<br>= 255: Maximum voltage at start-up  |
| 3.21              | #353 | Automatic turn-off of the smoke generator  | 0 - 255<br>=<br>0 - 106min | 0       | For effects "010010xx" or "010100xx" (smoke generator): overheating protection: Turn-off half a minute to 2 hours.<br>= 0: no automated shut-down<br>= 1 to 255: automatic turn-off after 25sec/unit  |
| 5.4               | #354 | Chuff beat frequency at speed step 1<br><br>also see CV #267 in this table   | 1 - 255                    | 11      | CV #354 works only if used together with CV #267!<br>CV #354 compensates for the non-linear speed measurements of the "virtual cam sensor":<br>While the adjustment of CV #267 is done in the vicinity of speed step 10 (slow but not very slow), a correction for speed step 1 can be performed with CV #354 (extremely slow).<br>= 0: no effect<br>= 1 - 127: Steam chuffs at speed step = 1 (and extremely slow speed) more common than CV #267<br>= 255 - 128: less chuff beats.  |
| 3.22              | #355 | Speed of the smoke fan at standstill for   | 1 - 255                    | 0       | With CV #355 the speed of the fan at standstill - if sound is switched on - is set. This has the effect of emitting   |

|     | CV   | Denomination  | Range   | Default | Description   |
|-----|------|---|---------|---------|---|
|     |      | STEAM locomotives, and DIESEL locomotives   |         |         | smoke (a small amount, but visible) even when stopped.  |
| 5.6 | #356 | Speedlock key   | 0 - 28  |         | If this key is activated, the speed controller changes the driving sound, not the speed   |
| 5.6 | #357 | Thyristor sound pitch:<br>Lowering volume at higher speed                         | 0 - 255 |         | Internal speed step at which the thyristor sound volume should be reduced. The volume stays at this reduced level while braking.<br>By changing CV #158 Bit 6 = 1, the volume will be raised while braking, nonetheless.  |
| 5.6 | #358 | Thyristor sound pitch:<br>Course of Lowering volume at higher speed               | 0 - 255 |         | Defines a curve as to how the thyristor sound should be lowered at the speed step defined in CV #357.<br>= 0: no reduction.<br>= 10: reduced by about 3 % per speed step.<br>= 255: aborts the sound when the speed step defined in CV #357 is reached.                 |
| 5.6 | #359 | Electric switch gear sound,<br>Switch gear playback duration during speed changes | 0 - 255 | 30      | Time in tenth of a second the switch gear should be heard during speed changes (adjustable from 0 - 25 sec.).<br>Effective only if switch gear sound is part of the sound project.  |
| 5.6 | #360 | Electric switch gear sound,<br>Duration of playback after stopping                | 0 - 255 | 0       | Time in tenth of a second the switch gear should be heard after the engine comes to a full stop (adjustable from 0 - 25 sec.).<br>= 0: no sound after stop.   |
| 5.6 | #361 | Electric switchgear<br>Time until the next playback                               | 0 - 255 | 20      | During rapid successions in speed changes the switch gear sound would be played back too often.<br>CV #361: Time in tenths of a second (0 - 25 sec.) defines minimum delay between multiple playbacks.  |
| 5.6 | #362 | Thyristor sound pitch:<br>Switching threshold to second sound:                    | 0 - 255 |         | Defines a speed step at which a second thyristor sound for higher speeds is played back; this was introduced for the sound project "ICN" (Roco OEM sound)<br>= 0: no second thyristor sound.  |
| 5.6 | #363 | Electric switch gear sound,<br>Distribution of speed steps on switching steps     | 0 - 255 | 0       | Number of shift steps to cover the whole speed range; i.e. if 10 shift steps are programmed, the switch gear sound is played back at internal speed step 25, 50, 75... (a total of 10 times)<br>= 0: synonymous with 5; i.e. 5 switch steps over the whole speed range. |
| 5.6 | #364 | Diesel engine with Switchgear<br>Speed drop during upshifts                       |         | 0       | This special CV applies only to diesel-mechanical engines and defines the typical drop in speed when shifting up. See sound projects (i.e. VT 61)   |
| 5.6 | #365 | Diesel engine with Switchgear<br>Upshift rpm                                      |         | 0       | This special CV applies only to diesel-mechanical engines and defines the highest rpm before shifting up. See sound projects (i.e. VT 61)   |
| 5.6 | #366 | Turbocharger<br>Maximum volume  | 0 - 255 | 48      |   |
| 5.6 | #367 | Minimum load for turbofor DIESEL engines<br>Turbo rpm depend-                     | 0 - 255 | 150     | Turbo playback frequency depending on engine speed.   |



|     | CV   | Denomination  | Range                  | Default        | Description  |
|-----|------|---|------------------------|----------------|--|
|     |      | ency on speed   |                        |                |  |
| 5.6 | #368 | Turbocharger Turbo rpm dependency on acceleration for DIESEL engines acceleration | 0 - 255                | 100            | Playback frequency depends on the difference of set speed to actual speed (= acceleration).  |
| 5.6 | #369 | Turbocharger Minimum load   | 0 - 255                | 30             | Audibility threshold for turbochargers; the load is derived from CV #367 and #368.   |
| 5.6 | #370 | Turbocharger Frequency increase   | 0 - 255                | 25             | Speed of frequency-increase of the turbocharger.   |
| 5.6 | #371 | Turbocharger frequency lowering   | 0 - 255                | 15             | Speed of frequency-decrease of the turbocharger.   |
| 5.6 | #372 | Electric motor Volume - Acceleration dependency                                   | 0 - 255                | 0              | = 0: No function<br>= 1 - 255: minimal to maximal effect   |
| 5.6 | #373 | Electric motor Volume - Dependent on braking                                      | 0 - 255                | 0              | = 0: No function<br>= 1 - 255: minimal to maximal effect   |
| 5.7 | #374 | Coasting-Key (or Notching) for diesel sound projects                              | 0 - 29                 | 0              | Function key that activates "Coasting", which forces the motor sound to a specified speed independent of the driving situation. Define the (sound) step in CV #375 (often used for idle sound while coasting).<br>= 0: does NOT mean F0, but rather that NO key is assigned for coasting.<br>= 1 - 28: One of the function keys F1 - F28 for "Coasting", 29 = F0 |
| 5.7 | #375 | Coasting step (or Notching)   | 0 - 10                 | 0              | Motor sound (speed) to be activated with the coasting key (as per CV #374), independent of the driving situation.<br>=0: Idle sound (typical coasting situations)<br>= 1 - 10: Sound step (Diesel engines typically have 5 to 10 notches), which can be activated with the coasting key (e.g. to represent auxiliary heating at standstill).                     |
| 5.3 | #376 | Driving sound Volume - (Multiplier)   | 0 - 255<br>= 0 - 100 % | 255<br>= 100 % | To reduce the driving sound volume (e.g. Diesel motor with related sounds such as turbo charger) compared to the function sounds.  |
| 5.6 | #378 | Statistical probability of switchgear sparks during Acceleration                  | 0 - 255                | 0              | Likelihood for sparks (as per CV #158 Bit 7 for FO7 or #394 for FO6) when accelerating<br>= 0: always<br>= 1: very rarely<br>= 255: very often (almost always)   |
| 5.6 | #379 | Statistical probability of switchgear sparks during Deceleration                  | 0 - 255                | 0              | Likelihood for sparks when decelerating (as per CV #158 Bit 7 for FO7 or #394 for FO6)<br>= 0: always<br>= 1: very rarely<br>= 255: very often (almost always)   |
| 5.6 | #380 | Manual electric brake key   | 1 - 28                 | 0              | Defines a function key to manually control the sound of a "dynamic" or "electric" brake.   |

|            | CV   | Denomination   | Range                    | Default | Description   |
|------------|------|--|--------------------------|---------|---|
|            |      | key  |                          |         |   |
| 5.6        | #381 | Electric brake minimal speed step                    | 0 - 255                  | 0       | The electric brake shall only be heard between the value defined in CV #381...  |
| 5.6        | #382 | Electric brake maximum speed step                    | 0 - 255                  | 0       | ...and the value in CV #382   |
| 5.6        | #383 | Electric brake Pitch                                 | 0 - 255                  | 0       | = 0: Pitch independent of speed<br>= 1 - 255: ...depends increasingly on speed.   |
| 5.6        | #384 | Electric brake Deceleration threshold                | 0 - 255                  | 0       | The number of speed steps to be reduced during deceleration before the electric brake sound is played back.   |
| 5.6        | #385 | Electric brake Driving on slopes                     | 0 - 255                  | 0       | = 0: no effect at "negative" load<br>= 1 - 255: Sound triggered at "negative" load.   |
| 5.6        | #386 | Electric brake Loop                                  | 0 - 15                   | 0       | Bit 3 = 0: Sound fades out at the end of the sample<br>= 1: Sound ends without fading at end<br>Bit 2 = 0: Prolongation of the minimal runtime of the braking sound by 0 to 7 seconds, to prevent an interruption in break sound between speed steps.   |
| 5.6        | #387 | Acceleration influence on diesel sound steps         | 0 - 255                  | 0       | In addition to the selected speed step (defined in the ZSP flow diagram), actual changes in speed (acceleration, deceleration) should also have an influence on the sound due to the associated increase or decrease in load.<br>= 0: No influence (sound depends on speed step only)<br>= 64: experience has shown this to be a practical value<br>= 255: maximum acceleration response (highest sound step during acceleration) |
| 5.6        | #388 | Deceleration influence On diesel sound steps         | 0 - 255                  | 0       | Same as CV #387 but used during decelerations.<br>= 0: No influence (sound depends on speed step only)<br>= 64: experience has shown this to be a practical value<br>= 255: maximum deceleration response   |
| 5.6        | #389 | Limited acceleration influence on diesel sound steps | 0 - 255                  | 0       | This CV determines how far the sound step may deviate during acceleration from the simple speed step dependence (= difference between target speed from the controller and actual speed).<br>= 0: No deviation; motor sounds according to schedule, sound does not depend on acceleration.<br>= 1 - 254: Dependence increases with value.<br>= 255: fully dependent on target speed.  |
| 3.7<br>5.6 | #390 | Momentum reduction when driving solo (engine only)   | 0 - 255                  | 0       | When switching to solo driving with key defined in CV #347 the momentum reduction is activated (with CV #348, Bit 1):<br>= 0 or 255: No reduction<br>= 128: Reduction to 50 %<br>= 64: Reduction to 25 %<br>= 1: virtually cancels all momentum.  |
| 5.6        | #391 | Driving with idle sound, when driving solo           | 0 - 255                  | 0       | The diesel motor sound should remain at idle when driving solo (with function key defined in CV #347), until the speed step defined in CV #391 is reached.  |
| 5.8        | #392 | Switch input 4 Playback duration                     | 0 - 255<br>= 0 - 255 sec | 0       | The sound sample allocated to switch input 4 is played back for the duration defined with this CV.<br>= 0: Play back sound sample for the first time  |



|             | CV   | Denomination  | Range                                    | Default | Description   |
|-------------|------|---|--|---------|---|
| 3.20<br>5.6 | #393 | ZIMO Config 5   |  | 0       | Bit 0 = 1: Activate ditch light if bell is played<br>Bit 1 = 1: Activate ditch light if horn is played<br>Bit 2 = 0: Always start with 1st sample of high speed switchgear<br>Bit 2 = 1: Use one sample after the other, if at the end, start again with 1st sample<br>Bit 3 = 0: Play first and last part when shifting up (middle part only when shifting down)<br>Bit 3 = 1: skip first and last part also when shifting up (like shifting down)<br>Bit 4 = 1: Thyristor 2 do not elevate pitch  |
|             |      |   |  |         | Bit 0 = 1: Light flashes at switchgear sound.<br>Bit 4 = 1: Faster acceleration and sound on high power when speed controller is set to full quickly<br>Bit 6 = 1: Impedes acceleration if brake key is active<br>Bit 7 = 1: Thyristor sound starts playing before start-up   |
| 3.7<br>5.6  | #394 | Bit 4: Faster Acceleration<br>Bit 4:  | 0 - 255                                  | -       |   |
| 5.3         | #395 | Maximum volume for volume increase key  | 0 - 255                                  | 64      | Configuration range for volume with the help of the louder key according to CV #397; can also be higher than the basic configuration in CV #266.  |
| 5.3         | #396 | volume decrease key   | 0 - 29                                   | 0       | 0 = No key defined.<br>1-28 = key F1 to F28 29 = F0-key   |
| 5.3         | #397 | Volume increase key   | 0 - 29                                   | 0       | 0 = No key defined.<br>1-28 = key F1 to F28 29 = F0-key   |
| 5.7         | #398 | Automatic Coasting  | 0 - 255                                  | 0       | The number of speed steps the train's speed has to be reduced within 0.5 seconds in order for the automatic coasting effect to set the motor sound to idle (without assigning a coasting key above). This effect does not occur at slowly reducing the speed steps.   |
| 3.17        | #399 | Speed dependent high beam<br>(Rule 17)<br><br>From SW version 5.00  | 0 - 255                                  | 0       | In combination with the "Swiss Mapping" special high-beam setting, see CV #431 = 255; applies to all 17 CV-groups (CV #437, #443, ...):<br>Switches to high-beam only when the speed exceeds the value in this CV; based on the decoder's internal 255 speed steps.<br>EXAMPLES and SPECIAL CASES:<br>= 0: High-beam at any speed (incl. stand-still), controlled only by the F-key (e.g. as per CV #430).<br>= 1: High-beam only while driving (not at stand-still), otherwise controlled by the F-key (e.g. CV #430).<br>= 128: Switches to high-beam when reaching medium speed.   |
| 3.18        | #400 | Input mapping for internal F0<br><br>that is, which function key switches the internal (decoder) function F0. | 0,<br>1 - 28, 29<br>30 - 187<br>254, 255 | 0       | = 0: Key F0 (i.e. F0 from the DCC packet) is sent to the internal F0 (1:1).<br>= 1: Key F1 is sent to the internal F0....<br>= 28: Key F28 is sent to the internal F0.<br>= 29: Key F0 is sent to the internal F0.<br>= 30: Key F1 to F0, only in forward direction<br>= 57: Key F28 to F0, only in forward direction<br>= 58: Key F0 to F0, only in forward direction<br>= 59: Key F1 to F0, only in reverse direction<br>= 86: Key F28 to F0, only in reverse direction.<br>= 87: Key F0 to F0, only in reverse direction<br>= 101: Key F1-inverted to internal F0....<br>= 187: Key F0-inverted to internal F0, only in reversed dr.<br>= 254: Direction bit to internal F0, in forward dir. |

|      | CV          | Denomination   | Range   | Default | Description  |
|------|-------------|--|---|---------|--|
|      |             |  |   |         | = 255: Directions Bit to internal F0, in reverse dir.  |
| 3.18 | #401 - #428 | Input mapping for internal F1 - F28  | 0,<br>1 - 28, 29,<br>30 - 255   | 0       | Same as input mapping above for other functions:<br>CV #403 = 1: Key F1 is forwarded to F3<br>= 9: Key F9 is forwarded to F3, etc.   |
| 3.17 | #430        | Swiss Mapping Group 1<br>"F-key"   | 0 - 28,<br>29 (for F0)<br>129 - 157                                     | 0       | With the F-key defined here, the FOs defined in A1 (forw or Rev) and A2 (forw or rev) shall be turned on.<br>Bit 7 = 1: Inverts the F-key function.  |
| 3.17 | #431        | Swiss Mapping Group 1<br>"M-key"<br><br>or<br><br>Special setting<br>"full beam" | Bit 0 - 6:<br>0 - 28,<br>29 (for F0)<br>and bit 7<br><br>or<br>255      | 0       | The "normal function mapping" of the M-key defined here shall be deactivated (i.e. the corresponding outputs like headlights are turned off), if the F-key is turned on.<br>Bit 7 = 1: additionally, the outputs listed under A1 and A2 should only switch ON if F and M key are ON.<br>Bit 6 = 1: The M-key outputs shall not be turned OFF if the F-key is ON and driving forward.<br>Bit 5 = 1: The M-key outputs shall not be turned OFF if the F-key is ON and driving backwards.<br>= 157: is an often-used value for CV #431, because F0 (=29) is usually defined as M-key with bit 7 = 1. F0 then acts as a general ON/OFF key.<br>= 255 (Special <b>high-beam</b> setting!): the FOs defined in the following four CVs are switched to full intensity, provided that they are controlled via the "normal function mapping", and dimmed with CV #60; this function is used, for example, to switch the headlights of a Swiss locomotive to high-beam, without switching the white taillight to high-beam.<br>Depending on CV #399: High beam is only switched on if the speed is higher than the value given in this CV (255 step mode). |
| 3.17 | #432        | Swiss Mapping Group 1<br>"A1" forward  | Bits 0 - 3:<br>1 - 12<br>14 (FO0f)<br>15 (FO0r)<br>Bits 5 - 7:<br>0 - 7 | 0       | Bits 0 - 3:<br>Function output to be switched ON in forward direction provided that both the "F" and "M"-keys are ON (if bit #7 for the M-key = 1, otherwise F-key ON is sufficient).<br>Bits 7, 6, 5 (7 possible values or zero):<br>Number of the applicable dimming CV. For example:<br>Bit 5 = 1 means dimming according to CV #508 etc.   |
| 3.17 | #433        | Swiss Mapping Group 1<br>"A2" forward  | Bits 0 - 3:<br>1 - 12<br>14 (FO0f)<br>15 (FO0r)<br>Bits 5 - 7:<br>0 - 7 | 0       | Bits 0 - 3:<br>Additional function output to be switched ON in forward direction provided that both the "F" and "M"-keys are ON (if bit #7 for the M-key = 1, otherwise F-key ON is sufficient).<br>Bits 7, 6, 5 (7 possible values or zero):<br>Number of the applicable dimming CV. For example:<br>Bit 5 = 1 means dimming according to CV #508 etc.  |
| 3.17 | #434        | Swiss Mapping Group 1<br>"A1" reverse  | Bits 0 - 3:<br>1 - 12<br>14 (FO0f)<br>15 (FO0r)<br>Bits 5 - 7:<br>0 - 7 | 0       | Bits 0 - 3:<br>Function output to be switched ON in reverse direction provided that both the "F" and "M"-keys are ON (if bit #7 for the M-key = 1, otherwise F-key ON is sufficient).<br>Bits 7, 6, 5 (7 possible values or zero):<br>Number of the applicable dimming CV. For example:<br>Bit 5 = 1 means dimming according to CV #508 etc.   |
| 3.17 | #435        | Swiss Mapping Group 1  | Bits 0 - 3:<br>1 - 12   | 0       | Bits 0 - 3:<br>Additional function output to be switched ON in reverse   |



|      | CV                                   | Denomination   | Range   | Default | Description  |
|------|--------------------------------------|--|---|---------|--|
|      |                                      | "A2" reverse   | 14 (FO0f)<br>15 (FO0r)<br>Bits 5 - 7:<br>0 - 7            |         | direction provided that <b>both</b> the "F" and "M"-keys are ON (if bit #7 for the M-key = 1, otherwise F-key ON is sufficient).<br>Bits 7, 6, 5 (7 possible values or zero):<br>Number of the applicable dimming CV. For example:<br>Bit 5 = 1 means dimming according to CV #508 etc.  |
| 3.17 | #436 - #441                          | ... Group 2.   | ...   | 0       | All 6 CVs in group 2 are defined the same way as the 6 CVs in group 1.   |
| 3.17 | #442 - #447                          | ... Group 3.   | ...   | 0       | All 6 CVs of the following groups are defined the same way is the 6 CVs in group 1.  |
| 3.17 | #448 - #453                          | ... Group 4.   | ...   | 0       | ...  |
| 3.17 | #454 - #459                          | ... Group 5.   | ...   | 0       | ...  |
| 3.17 | #460 - #465                          | ... Group 6.   | ...   | 0       | ...  |
| 3.17 | #466 - #471                          | ... Group 7.   | ...   | 0       | ...  |
| 3.17 | #472 - #477                          | ... Group 8.   | ...   | 0       | ...  |
| 3.17 | #478 - #483                          | ... Group 9.   | ...   | 0       | ...  |
| 3.17 | #484 - #489                          | ... Group 10.  | ...   | 0       | ...  |
| 3.17 | #490 - #495                          | ... Group 11.  | ...   | 0       | ...  |
| 3.17 | #496 - #501                          | ... Group 12.  | ...   | 0       | ...  |
| 3.17 | #502 - #507                          | ... Group 13.  | ...   | 0       | ...  |
| 3.17 | #508<br>#509<br>#510<br>#511<br>#512 | Dimming values for the "Swiss Mapping"<br><br>Special configurations | (0- 31)*8<br>(Only bits 3 - 7 are used)<br><br>Bits 0 - 2 | 248     | Each group-CV (i.e. #432, #433, #434, #435) can be linked to one of these five dimming CVs.<br>This means that the function outputs shall be dimmed accordingly when switched on.<br>Value 0 = dark, value 31 = not dimmed.<br>Usable only with function outputs FO0 to FO13.<br><br>Bit 0 = 1: suppresses the lighting effect<br>Bit 1 = 1: Flashing effect<br>Bit 2 = 1: Inverted flashing |
| 5.3  | #513                                 | Sound number F1  |   |         | Sample number of function sound on F1  |
| 5.3  | #514                                 | Function sound F1  | 0 - 255   | 0       | Volume adjustment  |
| 5.3  | #515                                 | Loop info F1   |   |         | Bit 0 to Bit2: Loop count 0-7<br>Bit 3 = 1: repeat when on (=active F-key) = sound "loop".<br>Bit 4 = 1: play sound only if forward direction is present<br>Bit 5 = 1: play sound only if backward direction is present<br>Bit 6 = 1: cancel when off (=deactivated F-key), =sound "shorten"   |

|     | CV   | Denomination       | Range   | Default | Description   |
|-----|------|--------------------|---------|---------|---|
|     |      |                    |         |         | Bit 7 = 1: play sound only if drive and random sounds are active (if F-button defined in CV #310 is pressed/active) |
| 5.3 | #516 | Sound number F2    |         |         | Sample number of function sound on F2   |
| 5.3 | #517 | Function sound F2  | 0 - 255 | 0       | Volume adjustment   |
| 5.3 | #518 | Loop info F2       |         |         | Same as CV #515 but for F2  |
| 5.3 | #519 | Sound number F3    |         |         | Sample number of function sound on F3   |
| 5.3 | #520 | Function sound F3  | 0 - 255 | 0       | Volume adjustment   |
| 5.3 | #521 | Loop info F3       |         |         | Same as CV #515 but for F3  |
| 5.3 | #522 | Sound number F4    |         |         | Sample number of function sound on F4   |
| 5.3 | #523 | Function sound F4  | 0 - 255 | 0       | Volume adjustment   |
| 5.3 | #524 | Loop info F4       |         |         | Same as CV #515 but for F4  |
| 5.3 | #525 | Sound number F5    |         |         | Sample number of function sound on F5   |
| 5.3 | #526 | Function sound F5  | 0 - 255 | 0       | Volume adjustment   |
| 5.3 | #527 | Loop info F5       |         |         | Same as CV #515 but for F5  |
| 5.3 | #528 | Sound number F6    |         |         | Sample number of function sound on F6   |
| 5.3 | #529 | Function sound F6  | 0 - 255 | 0       | Volume adjustment   |
| 5.3 | #530 | Loop info F6       |         |         | Same as CV #515 but for F6  |
| 5.3 | #531 | Sound number F7    |         |         | Sample number of function sound on F7   |
| 5.3 | #532 | Function sound F7  | 0 - 255 | 0       | Volume adjustment   |
| 5.3 | #533 | Loop info F7       |         |         | Same as CV #515 but for F7  |
| 5.3 | #534 | Sound number F8    |         |         | Sample number of function sound on F8   |
| 5.3 | #535 | Function sound F8  | 0 - 255 | 0       | Volume adjustment   |
| 5.3 | #536 | Loop info F8       |         |         | Same as CV #515 but for F8  |
| 5.3 | #537 | Sound number F9    |         |         | Sample number of function sound on F9   |
| 5.3 | #538 | Function sound F9  | 0 - 255 | 0       | Volume adjustment   |
| 5.3 | #539 | Loop info F9       |         |         | Same as CV #515 but for F9  |
| 5.3 | #540 | Sound number F10   |         |         | Sample number of function sound on F10  |
| 5.3 | #541 | Function sound F10 | 0 - 255 | 0       | Volume adjustment   |
| 5.3 | #542 | Loop info F10      |         |         | Same as CV #515 but for F10   |
| 5.3 | #543 | Sound number F11   |         |         | Sample number of function sound on F11  |
| 5.3 | #544 | Function sound F11 | 0 - 255 | 0       | Volume adjustment   |
| 5.3 | #545 | Loop info F11      |         |         | Same as CV #515 but for F11   |
| 5.3 | #546 | Sound number F12   |         |         | Sample number of function sound on F12  |
| 5.3 | #547 | Function sound F12 | 0 - 255 | 0       | Volume adjustment   |
| 5.3 | #548 | Loop info F12      |         |         | Same as CV #515 but for F12   |
| 5.3 | #549 | Sound number F13   |         |         | Sample number of function sound on F13  |
| 5.3 | #550 | Function sound F13 | 0 - 255 | 0       | Volume adjustment   |
| 5.3 | #551 | Loop info F13      |         |         | Same as CV #515 but for F13   |
| 5.3 | #552 | Sound number F14   |         |         | Sample number of function sound on F14  |
| 5.3 | #553 | Function sound F14 | 0 - 255 | 0       | Volume adjustment   |
| 5.3 | #554 | Loop info F14      |         |         | Same as CV #515 but for F14   |
| 5.3 | #555 | Sound number F15   |         |         | Sample number of function sound on F15  |



|     | CV   | Denomination                     | Range                     | Default | Description   |
|-----|------|----------------------------------|---------------------------|---------|---|
| 5.3 | #556 | Function sound F15               | 0 - 255                   | 0       | Volume adjustment   |
| 5.3 | #557 | Loop info F15                    |                           |         | Same as CV #515 but for F15   |
| 5.3 | #558 | Sound number F16                 |                           |         | Sample number of function sound on F16  |
| 5.3 | #559 | Function sound F16               | 0 - 255                   | 0       | Volume adjustment   |
| 5.3 | #560 | Loop info F16                    |                           |         | Same as CV #515 but for F16   |
| 5.3 | #561 | Sound number F17                 |                           |         | Sample number of function sound on F17  |
| 5.3 | #562 | Function sound F17               | 0 - 255                   | 0       | Volume adjustment   |
| 5.3 | #563 | Loop info F17                    |                           |         | Same as CV #515 but for F17   |
| 5.3 | #564 | Sound number F18                 |                           |         | Sample number of function sound on F18  |
| 5.3 | #565 | Function sound F18               | 0 - 255                   | 0       | Volume adjustment   |
| 5.3 | #566 | Loop info F18                    |                           |         | Same as CV #515 but for F18   |
| 5.3 | #567 | Sound number F19                 |                           |         | Sample number of function sound on F19  |
| 5.3 | #568 | Function sound F19               | 0 - 255                   | 0       | Volume adjustment   |
| 5.3 | #569 | Loop info F19                    |                           |         | Same as CV #515 but for F19   |
|     | #570 | Sound number F0                  |                           |         | Sample number of function sound on F0   |
| 5.3 | #571 | Function sound F0                | 0 - 255<br>= 100, 1-100 % | 0       | Sound volume operated with function key F0 = 0: full volume, original sound sample volume (same as 255) = 1 - 254: reduced volume 1 - 99.5 % = 255: full volume |
|     | #572 | Loop info F0                     |                           |         | Same as CV #515 but for F0  |
|     | #573 | Sound number simmering           |                           |         | Sample number   |
| 5.3 | #574 | "Simmering"                      | 0 - 255                   | 0       | Volume driving sound "simmering"  |
|     | #575 | Sound number change of direction |                           |         | Sample number   |
| 5.3 | #576 | Sound "changing directions"      | 0 - 255                   | 0       | Volume driving sound for e.g. Johnson Bar   |
|     | #577 | Sound number brake squeal        |                           |         | Sample number   |
| 5.3 | #578 | "Brake squeal"                   | 0 - 255                   | 0       | Brake squeal volume   |
|     | #579 | Sound number thyristor sound     |                           |         | Sample number   |
| 5.3 | #580 | Thyristor sound                  | 0 - 255                   | 0       | Thyristor sound volume (ELECTRIC engine)  |
|     | #581 | Sound number starting whistle    |                           |         | Sample number   |
| 5.3 | #582 | "Starting whistle"               | 0 - 255                   | 0       | Volume Starting whistle (STEAM/DIESEL)  |
|     | #583 | Sound number blow-off            |                           |         | Sample number   |
| 5.3 | #584 | Blow-off                         | 0 - 255                   | 0       | Blow-off volume (STEAM engine)  |
|     | #585 | Sound number electric motor      |                           |         | Sample number   |
| 5.3 | #586 | Electric motor                   | 0 - 255                   | 0       | Electric motor volume (ELECTRIC engine)   |
|     | #587 | Sound number                     |                           |         | Sample number   |

|     | CV   | Denomination               | Range   | Default | Description  |
|-----|------|----------------------------|---------|---------|--|
|     |      | rolling sound              |         |         |  |
|     | #588 | "Rolling sound"            | 0 - 255 | 0       | Driving sounds volume (rolling/wheels)   |
|     | #589 | Sound number switchgear    |         |         | Sample number  |
| 5.3 | #590 | Electric switch gear sound | 0 - 255 | 0       | Switch gear volume (ELECTRIC engine)   |
| 5.3 | #600 | Turbo                      | 0 - 255 | 0       | Turbocharger volume (DIESEL engine)  |
| 5.3 | #602 | Dynamic brakes             | 0 - 255 | 0       | Volume "dynamic brake"   |
| 5.3 | #604 | "Brake squeal"             | 0 - 255 | 0       | Volume "cornering squeal"  |
| 5.3 | #671 | Switch input sound S4      | 0 - 255 | 0       | Number of sound sample for input S4  |
| 5.3 | #672 | Switch input sound S4      | 0 - 255 | 0       | Volume setting for the sound activ. with switch input S4   |
| 5.3 | #673 | Sound number F20           |         |         | Sample number of function sound on F20   |
| 5.3 | #674 | Function sound F20         | 0 - 255 |         | Volume adjustment  |
| 5.3 | #675 | Loop info F20              |         |         | Same as CV #515 but for F20  |
| 5.3 | #676 | Sound number F21           |         |         | Sample number of function sound on F21   |
| 5.3 | #677 | Function sound F21         | 0 - 255 |         | Volume adjustment  |
| 5.3 | #678 | Loop info F21              |         |         | Same as CV #515 but for F21  |
| 5.3 | #679 | Sound number F22           |         |         | Sample number of function sound on F22   |
| 5.3 | #680 | Function sound F22         | 0 - 255 |         | Volume adjustment  |
| 5.3 | #681 | Loop info F22              |         |         | Same as CV #515 but for F22  |
| 5.3 | #682 | Sound number F23           |         |         | Sample number of function sound on F23   |
| 5.3 | #683 | Function sound F23         | 0 - 255 |         | Volume adjustment  |
| 5.3 | #684 | Loop Info F23              |         |         | Same as CV #515 but for F23  |
| 5.3 | #685 | Sound number F24           |         |         | Sample number of function sound on F24   |
| 5.3 | #686 | Function sound F24         | 0 - 255 |         | Volume adjustment  |
| 5.3 | #687 | Loop info F24              |         |         | Same as CV #515 but for F24  |
| 5.3 | #688 | Sound number F25           |         |         | Sample number of function sound on F25   |
| 5.3 | #689 | Function sound F25         | 0 - 255 |         | Volume adjustment  |
| 5.3 | #690 | Loop info F25              |         |         | Same as CV #515 but for F25  |
| 5.3 | #691 | Sound number F26           |         |         | Sample number of function sound on F26   |
| 5.3 | #692 | Function sound F26         | 0 - 255 |         | Volume adjustment  |
| 5.3 | #693 | Loop info F26              |         |         | Same as CV #515 but for F26  |
| 5.3 | #694 | Sound number F27           |         |         | Sample number of function sound on F27   |
| 5.3 | #695 | Function sound F27         | 0 - 255 |         | Volume adjustment  |
| 5.3 | #696 | Loop info F27              |         |         | Same as CV #515 but for F27  |
| 5.3 | #697 | Sound number F28           |         |         | Sample number of function sound on F28   |
| 5.3 | #698 | Function sound F28         | 0 - 255 |         | Volume adjustment  |
| 5.3 | #699 | Loop info F28              |         |         | Same as CV #515 but for F28  |
| 5.3 | #726 | Connection 1 sound         |         | 0       | Sound number for connection 1 (usually defined by sound project and should not be changed if possible). Within the documentation of (most of the) sound projects sound numbers are listed. |
| 5.3 | #727 | Connection 1 FO            |         | 0       | Function output to connection 1 which shall be activated - if the sound is played back. 1 = FO0f, 2 = FO0r, 3 = FO1, ...   |



|     | CV                  | Denomination                | Range                        | Default | Description   |
|-----|---------------------|-----------------------------|------------------------------|---------|---|
| 5.3 | #728                | Connection 2 sound          |                              | 0       | Sound number to connection 2  |
| 5.3 | #729                | Connection 2 FO             |                              | 0       | Function output to connection 2:<br>1 = FO0f, 2 = FO0r, 3 = FO1, ...  |
| 5.3 | #730<br>...<br>#735 | ...                         |                              | 0       | ...   |
| 5.3 | #736                | Conn. 6 sound               |                              | 0       | Soundnumber to connection 6.  |
| 5.3 | #737                | Connection 6 FO             |                              | 0       | Function output to connection 6:<br>1 = FO0f, 2 = FO0r, 3=FO1, ...  |
|     | #738                | Reed 1 sound number         |                              |         | Sample number according to sample info for switch input S1  |
| 5.3 | #739                | Switch input sound S1       | 0 - 255<br>=<br>100, 1-100 % | 0       | Volume setting for the sound activated with switch input S1<br>= 0: full volume, original sound sample volume (same as 255)<br>= 1 - 254: reduced volume 1 – 99.5 %<br>= 255: full volume |
|     | #740                | Reed 2 sound number         |                              |         | Sample number according to sample info for switch input S2  |
| 5.3 | #741                | Switch input sound S2       | 0 - 255                      | 0       | Volume setting for the sound activated with switch input S2   |
|     | #742                | Reed 3 sound number         |                              |         | Sample number according to sample info for switch input S3  |
| 5.3 | #743                | Switch input sound S3       | 0 - 255                      | 0       | Volume setting for the sound activated with switch input S3   |
|     | #744                | Random Sound Z1             |                              |         | Sample number of function sound on Z1   |
| 5.3 | #745                | Function sound Z1           |                              |         | Volume setting for sound activated by random generator Z1   |
|     | #746                | Random sound Z1 - info      |                              |         | Bit3=1: Random sound Z1 may come at standstill<br>Bit6=1: Random sound Z1 may come when moving  |
|     | #747                | Random Sound Z2             |                              |         | Sample number of function sound on Z2   |
| 5.3 | #748                | Function sound Z2           |                              |         | Volume setting for sound activated by random generator Z2   |
|     | #749                | Random sound Z2 - Loop info |                              |         | Bit3=1: Random sound Z2 may come at standstill<br>Bit6=1: Random sound Z2 may come when moving  |
|     | #750                | Random Sound Z3             |                              |         | Sample number of function sound on Z3   |
| 5.3 | #751                | Function sound Z3           |                              |         | Volume setting for sound activated by random generator Z3   |
|     | #752                | Random sound Z3 - Loop info |                              |         | Bit3=1: Random sound Z3 may come at standstill<br>Bit6=1: Random sound Z3 may come when moving  |
|     | #753                | Random Sound Z4             |                              |         | Sample number of function sound on Z4   |
| 5.3 | #754                | Function sound Z4           |                              |         | Volume setting for sound activated by random generator Z4   |
|     | #755                | Random sound Z4 - Loop info |                              |         | Bit3=1: Random sound Z4 may come at standstill<br>Bit6=1: Random sound Z4 may come when moving  |
|     | #756                | Random Sound Z5             |                              |         | Sample number of function sound on Z5   |
| 5.3 | #757                | Function sound Z5           |                              |         | Volume setting for sound activated by random generator Z5   |
|     | #758                | Random sound Z5 - Loop info |                              |         | Bit3=1: Random sound Z5 may come at standstill<br>Bit6=1: Random sound Z5 may come when moving  |
|     | #759                | Random Sound Z6             |                              |         | Sample number of function sound on Z6   |

|            | CV          | Denomination                        | Range   | Default | Description  |
|------------|-------------|-------------------------------------|---|---------|--|
| 5.3        | #760        | Function sound Z6                   |   |         | Volume setting for sound activated by random generator Z6  |
|            | #761        | Random sound Z6 - Loop info         |   |         | Bit3=1: Random sound Z6 may come at standstill<br>Bit6=1: Random sound Z6 may come when moving   |
|            | #762        | Random Sound Z7                     |   |         | Sample number of function sound on Z7  |
| 5.3        | #763        | Function sound Z7                   |   |         | Volume setting for sound activated by random generator Z7  |
|            | #764        | Random sound Z7 - Loop info         |   |         | Bit3=1: Random sound Z7 may come at standstill<br>Bit6=1: Random sound Z7 may come when moving   |
|            | #765        | Random Sound Z8                     |   |         | Sample number of function sound on Z8  |
| 5.3        | #766        | Function sound Z8                   |   |         | Volume setting for sound activated by random generator Z8  |
|            | #767        | Random sound Z8 - Loop info         |   |         | Bit3=1: Random sound Z8 may come at standstill<br>Bit6=1: Random sound Z8 may come when moving   |
| 3.17       | #800 - #805 | Swiss Mapping Group 14 "A2" reverse | Bits 0 - 3:<br>1 - 12<br>14 (FO0f)<br>15 (FO0r)<br>Bits 5 - 7:<br>0 - 7 | 0       | Bits 0 - 3:<br>Additional function output to be switched ON in reverse direction provided that <u>both</u> the "F" and "M"-keys are ON (if bit #7 for the M-key = 1, otherwise F-key ON is sufficient).<br>Bits 7, 6, 5 (7 possible values or zero):<br>Number of the applicable dimming CV. For example:<br>Bit 5 = 1 means dimming according to CV #508 etc. |
| 3.17       | #806 - #811 | ... - Group 15                      | ...   | 0       | ...  |
| 3.17       | #812 - #817 | ... - Group 16                      | ...   | 0       | ...  |
| 3.17       | #818 - #823 | ... - Group 17                      | ...   | 0       | ...  |
| 3.12       | #830        | Braking distance forward High Byte  | 0 - 255   | 0       | Supplementary to CV #140:  |
| 3.12       | #831        | Braking distance forward Low Byte   | 0 - 255   | 0       | Extended definition of the Constant Braking Distance: With CV #830 - #833 a more precise and direction dependent braking distance can now be set. The factor compared to CV #141 is 1 to 16.   |
| 3.12       | #832        | Braking distance backward High Byte | 0 - 255   | 0       | The braking distance to be defined is calculated from: (256 * High Byte) + Low Byte.   |
| 3.12       | #833        | Braking distance backward Low Byte  | 0 - 255   | 0       | CVs 830 - 833 are only effective if CV #141 = 0.   |
| 5.3<br>5.6 | #835        | Number of set+keys                  |   |         | Number of set switching keys. These keys are always located one after the other, beginning with the key defined in CV #345.  |
| 5.6        | #836        | Motor Start Sound                   | Bit 0   |         | Bit 0 = 1: Bit 0 = 1: Loco shall not start driving before Start sound is fully played.   |
| 8          | #837        | Script processes                    | Bit 0-7   | 0       | Bit 0 - 7 = 1: Deactivate scripts 1 - 8  |
| 5.6        | #838        | Thyristors Maximum speed            | 0 - 255   | 255     | Definition of the "maximum" speed level (1 - 255) for which pitch applies according to CV #291.  |
|            | #839        | Software Version                    |   | 0       | Decoder Software, second Subversion  |
| 8          | #843        | Script processes                    |   | 0       | Bit 0 - 7 = 1: Deactivate scripts 9 - 16   |
|            | #844        | E-motor sound max. pitch            |   |         | = 0: Limitation at value 100 (like MX Sound Decoder)   |
|            | #980 -      | Script CVs, see changelog ZSP       |   | 0       | Values of these CVs are read by scripts. This allows to change values in scripts when the project is stored in   |

|  | CV    | Denomination | Range | Default | Description  |
|--|-------|--------------|-------|---------|--------------|
|  | #1019 |              |       |         | the decoder. |

|      | CVs in higher CV pages  | Description  |
|------|---|--|
| 3.25 | <b>CV-Page 145/0</b><br>(i.e.. CV #31 = 145, CV #32 = 0)<br>CVs #262 - #277, #281 - #284  | For large scale decoder, if more than 4 servos can be operated: Identical meaning as CV page 0 (main page), CVs #162 - #177 resp. #181 - #184, but for servo control lines 5 to 8 (instead of 1 to 4)  |
| 3.22 | <b>CV-Page 145/0,</b><br>(i.e. CV #31 = 145, CV #32 = 0)<br>CVs #501, #502, #505  | from SW version 5.00 or later<br>Identical meaning as CV page 0 (main page), CVs #351, #352, #355 (there for fan V1), but fan output V2.   |
|      | <b>CV-Page 145/2,</b><br>CV #257 - 260, 261 - 264, bis 280<br>6 filter stages with 4 parameters each:<br>Filter type   Cut-off frequency<br>Quality factor   Gain | as of SW version 4.229<br>Filter type: 0 = no filter (deactivated)   1 = lowpass   2 = highpass<br>3 = Bandpass   4 = LowShelf   5 = HighShelf   6 = Notch   7 = Peak<br>Cutoff frequency 64Hz to 16kHz: $(\log(\text{cutoff frequency}) * 32 / \log(2))$<br>- 192, etc. |



## 9 Scripts for decoders, short description

ZIMO decoders contain many features ... and more are added with time. A lot, but not everything regarding the decoder configuration, especially concerning sound sequences, can be displayed with CVs without any problems. Therefore, in cooperation with external partners - especially the sound providers - the scripts were introduced.

In the currently existing form scripts are NOT directly programmable (e.g. via PoM), but only available **as part of sound projects**. In the software ZSP ("ZIMO Sound Programmer") there is an editor for creating scripts.

In the following (right) the first page of the special instruction for "ZSP-Scripts" is shown (state of printing: 01/2020):

[www.zimo.at / Manuals / ZIMO User Manuals / Row „ZSP“ / English User Manual](http://www.zimo.at/Manuals/ZIMO%20User%20Manuals/Row%20„ZSP“/English%20User%20Manual)

| CV   | Bezeichnung                    | Bereich | Default | Beschreibung                            |
|------|--------------------------------|---------|---------|---|
| #837 | Deactivation scripts<br>1 - 8  |         | 0       | Bit 0 - 7 = 1: Deactivate Script 1 - 8  |
| #843 | Deactivation scripts<br>9 - 16 |         | 0       | Bit 0 - 7 = 1: Deactivate script 9 - 16 |

### 8.A Scripts

In order to program sequences and dependencies, in ZSP you can make use of "Scripts", a type of programmable sequences. To create them, no programming knowledge is needed, because within ZSP you can program the sequences in an interactive editor. It offers predefined functions to select from drop-down menus and - depending on the command - further items appear to configure the corresponding parameters.

But first, let's stay with the basics...

#### a. How do I get there?

Start the ZSP application as usual - if isn't started yet. Find the scripts section in the tab "CV settings", then click on the top button on the bottom right: "Script". See left picture:

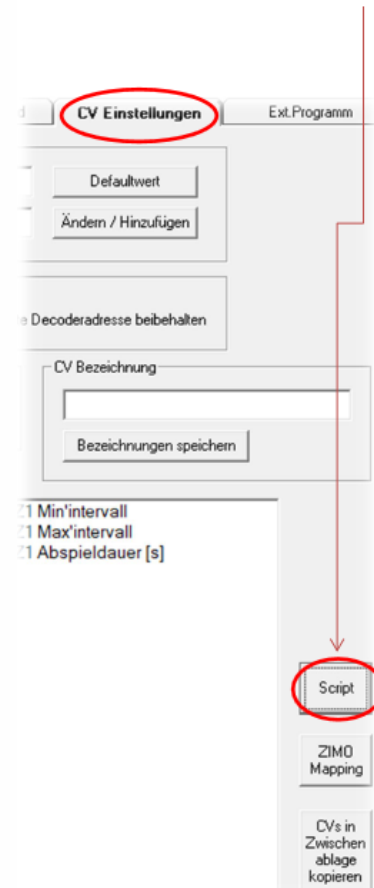

Now, a small window opens with an empty, white area. To create a script, click on "Hinzufügen" (Add) and a blue-marked field "Script 1" appears. With "Umbenennen" (rename) the script can be given a characteristic name, so it is easier to identify later on. Double-clicking the script opens an empty editor. In case it does not open (or you cannot find the window on your screen) click on "Script Fenster zurücksetzen" (reset window position), and the window will appear on the upper left corner of your screen.

A shortcut directly to the Script Editor can be found in the topmost menu bar of the general ZSP window with

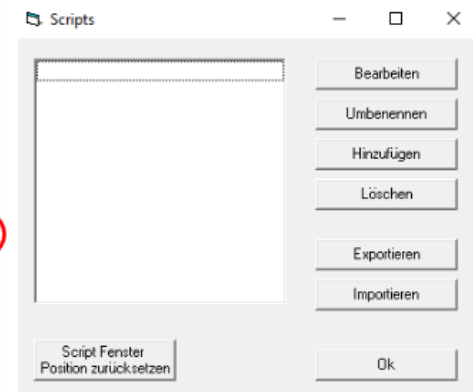

Script1



## 10 Software update and sound loading with MXULFA

Valid for MXULF SW version 0.84....

Short description for loading new software versions (update) and sound projects into a single\*) MS de-

**ATTENTION:** Update of "early" MS decoders (up to SW 4.08, 1st half of 2020) NOT described

coder; full description see instruction manual MXULF(A).

\*) For production and maintenance work, there are also update and loading procedures for several decoders at the same time, which is not the subject of this brief description, nor is driving operation, etc.

**IMPORTANT: Update MXULFA to the latest version by self-update!**

Especially in the phase of the market launch of numerous new MS decoder types, i.e. at least still in 2021, new versions are constantly necessary.

- Download new MXULF software from [www.zimo.at](http://www.zimo.at) – Update & Sound – Decoder-Update-Device MXULF as .zip file, **unzip** the .zip file, **save** the two actual update files MXULF.ulf and MXULF.bin (names may be slightly different) in the main directory (root) of a **USB stick** (ZIMO stick or other stick - most of them work ...).
- Preparing the MXULF: Disconnect all connections, reconnect "Power" (to supplied power supply unit or rail output of a digital centre) → LED "Power"-green.
- Insert the **USB stick** prepared above → LED flashes red-green-yellow (if correct files, i.e. .ulf and .bin, have been found on the USB stick).
- Start self-update with **button 3** (long, approx. 3 sec).
- Wait for message "SELF-UPDATE OK" "CRC OK" may also appear instead!
- Disconnect USB stick, disconnect „Power“.
- Reconnect „Power“ → MXULF ready for use. Displayed is "MXULF", hardware revision: + stands for the optimized RailCom detector hardware, no matter if it is originally installed or by subsequent upgrade, which was/will be offered from the turn of the year 2021/22.

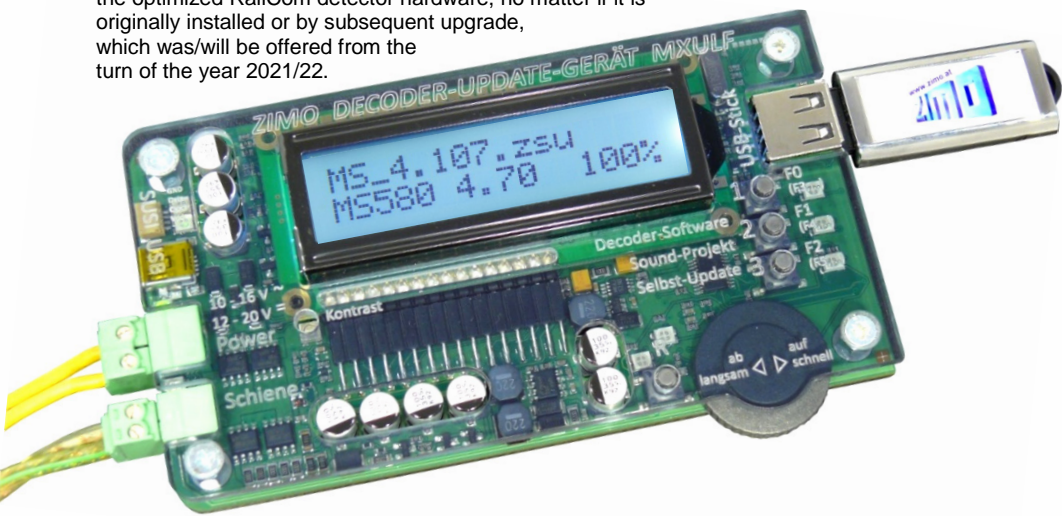
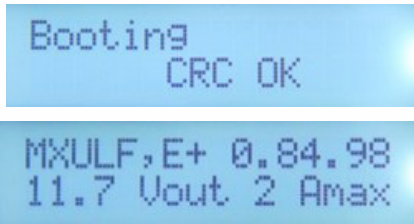

There are different types of update and loading processes, which differ from each other: **USB stick | from the computer** and **via track | via SUSI pins**

**Decoder software update via USB stick via track** (decoder installed in loco)

- Download new **decoder SW collection file** .zsu file - (**ATTENTION:** only valid if collection file for MS decoders) - from [www.zimo.at](http://www.zimo.at) – Update & Sound – Update MS-Decoder and save it to the main directory (root) of a **USB stick**; preferably (simpler) just this one .zsu file on the stick \*)
- Connect "Power" (power supply or ...) to the MXULF → LED „Power“ green.
- Connect the track, rerail the vehicle (only vehicle on track) → LED "Schiene" yellow.
- Insert the prepared **USB stick** → LED "1" yellow (if decoder SW collection file found), name of the decoder SW collection file shown on display.
- Start the decoder update with **button 1** → Search of the decoder type (mostly only briefly displayed), then automatically continue to the "Release memory ...", and Update with progress display...
- Wait for message „100 %“.
- Derail the vehicle, and - if the charging or further update process is to be initiated:
- Confirm with **button 1**, then
  - if the sound project is on the same USB stick, i.e. LED "2" yellow, start sound loading with button 2 (as below), or
  - set up a new vehicle for update with identical SW version.

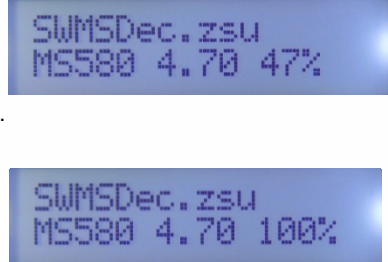

**NOTE for DOWNGRADES (= update to older SW version than currently loaded):**

Basically, a SW-UPDATE can be an UPGRADE (this is the "normal" process: update to a newer version) or a DOWNGRADE (these are exceptional cases: update to an older version).

**ATTENTION:** On decoders that have been built and delivered with SW versions **4.200 or higher** (approx. from October 2021), **NO DOWNGRADE** to SW versions **below 4.200** can be made; however (if delivery still higher) to 4.200 and higher.

other component is used alternatively as sound memory, which behaves outwardly identically to the original one, but which must be controlled differently. The decoder software has been adapted as of version 4.200 so that both types of memory can be used.

Therefore, an UPGRADE is possible for ALL decoders (also those with the original memory device), but the DOWNGRADE is limited to the range below or above version 4.200.

Decoders with delivery software (independent of the currently loaded software) are internally marked (not CV-readable), which is recognized by the MXULFA and represented by a suffix "-1" when searching (not during the update process itself), e.g. MS440-1, MS450-1, MS580-1, ...

In the event of an attempt at a non-feasible downgrade the MXULFA shows the message "SW < 4.200 not allowed here".



**Decoder sound load via USB stick via track (decoder installed in loco)**

➤ Download the desired **sound project** .zpp file - from [www.zimo.at](http://www.zimo.at) – Update & Sound – ZIMO

**NOTE:** Charging via the track is **slow** - 1 hour and more. Fast alternative via SUSI Pins.

[Sound Database](#) and save it to the main directory (root) of a **USB stick**; preferably (simpler) just this one .zpp file on the stick \*)

- **Connect "Power"** (power supply or ...) to the MXULF → LED "Power" green.
- **Connect the track, rerail the vehicle** → LED "Schiene" yellow.
- **Insert the prepared USB stick** → LED "2" yellow (if sound project, i.e. zpp file found), name of the sound project shown on display.
- **Start the sound load with button 2**  
→ Progress indicator on the display.
- **Wait for message „Sound 100 %“.**
- **Derail the vehicle**, and - if the charging or further update process is to be initiated:
- **Confirm with button R**, then ready again

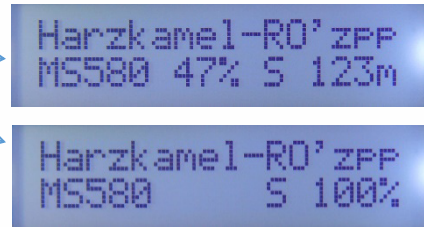

\*) If there are several .zsu or .zpp files on the stick (or both types mixed), the first two files are displayed immediately and the others can be made visible by scrolling. The file marked with an arrow is then ready to be loaded into the decoder. The process is started by pressing key 1 or key 2; the key must match the selected file, i.e. key 1 if the .zsu file is selected (decoder update), or key 2 if the .zpp file is selected (sound loading).

**Connecting the decoder to the MXULFA for SW update and sound loading**

If the decoder to be processed is NOT installed in a loco (which is placed on an "update track", to be connected to MXULFA "rail") a connection and test board, equipped with the usual decoder interfaces, is mostly used for contacting: MSTAPK for all "small" MS decoders (essentially also suitable for "small" MX decoders) or MSTAPG for MS large scale decoders (not for MX) or MXTAPV for all MX decoders ("small" and "large").

**EXAMPLES:**

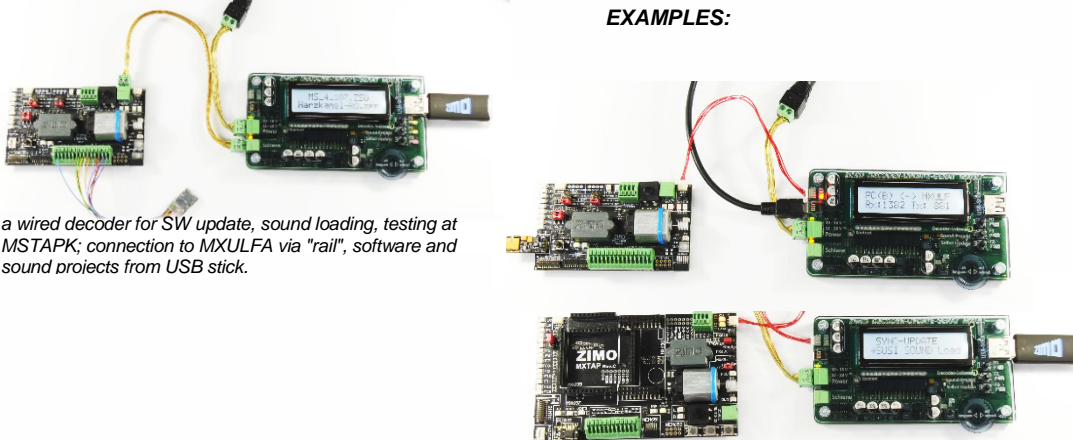

a wired decoder for SW update, sound loading, testing at MSTAPK; connection to MXULFA via "rail", software and sound projects from USB stick.

A "PluX" decoder for SW update and sound loading to MXTAPV; connection to MXULFA via "SUSI" cable, but NO cable "rail" from MXULFA to TAP!

**Decoder sound load via USB flash drive using the SUSI pins (decoder outside loco).**

**NOTE:** SUSI loading is the **fast** alternative (approx. factor 10 compared to track); however, only possible if the decoder is **NOT installed**. Normally the connector locations (PluX, MTC, Next18, ...) on a test and connection board **MXTAP** or **MSTAP** are used. With wired decoders (also with NEM-651 or -652) sound loading via the SUSI pins is possible, but the SUSI connections (no pins present) must be made accessible by soldered wires.

- As with sound loading via the track:  
**Save** the desired **sound project** ..... on a **USB flash drive** (for simplicity's sake, just this one). \*)
- **Connect "Power"** (power supply or ...) to the MXULF → LED „Power“ green.
- Connect the **connection board (MXTAP or MSTAP)** to the MXULF by means of a **track connection** ("Track" connections) OR by means of a **SUSI cable** ("SUSI" connections).
- **Connect the decoder** to a suitable interface (PluX, MTC, Next18, ...), for safety's sake with the connection board switched off (on/off switch on the board).
- **Switch on the connection board** (switch-on status recognisable by various LEDs).
- **R button** (long, approx. 3 sec)  
Opens the MXULF menu on the display.
- Use **scroll wheel**:  
Select "**SUSI SOUND Load**" entry
- **R button** (briefly) → Start the sound load  
Progress indicator on the display
- **Wait for message „S... 100 %“**
- **Confirm with Button R**, then ready again

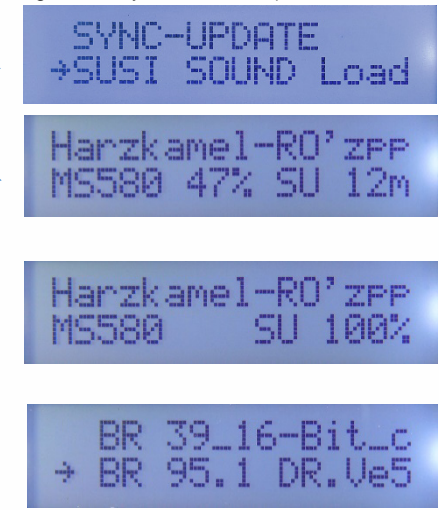

\*) If there are several .zpp files on the stick, they will be displayed. One must be selected by scrolling.

**Decoder software update and decoder sound loading DIRECTLY FROM THE COMPUTER**

With software ZSP or ZCS via USB cable from computer to MXULF. The MXULF display then only shows the data transfer; operation is performed in the respective software.

a "Next18" decoder for SW update and sound loading to MSTAPK; connection to MXULFA via "SUSI" cable. NO cable "rail"!  
Software and sound projects from computer (programs ZSP or ZCS) via USB cable.

MORE INFO  
WILL FOLLOW (based on ZCS)

## 11 Service Notes

Even ZIMO decoders can break down ... sometimes "for no reason", sometimes due to short circuits during installations, sometimes by a failed update ...

These defective decoders can of course be sent to Zimo for repair or replacement. Whether this is covered by warranty or a payable service, the submitter should expect a decoder back that is not only functional, but is also configured similarly as the original (i.e. the same CV values and the same sound project).

However, this is not possible if the decoder is damaged so badly that it cannot be read-out anymore.

To be sure, important data are not lost, you should

**SAVE, i.e. READ OUT IMPORTANT DATA** from the decoder as long as this is possible, i.e. the decoder is not defective, to communicate the data to ZIMO if necessary or to have them available for a replacement decoder:

- loaded SW version (CV #7, #65)
- possibly activated CV set (activation code for CV #8, concerns non-sound decoder)
- Decoder ID (CV #250 - #253, if available)
- Possibly load code (CV #260 - #263, relates to sound decoder)
- loaded sound project.

It would also be **very useful** (but relatively complex) to read out the entire CV list and keep it in a safe place, so it can later be programmed into a repaired decoder (which sometimes requires a hard-reset) or a replacement. Reading out and reprogramming decoders is easy with the help of

- the program "ADaPT" (from E. Sperrer, works with ZIMO and some other DCC systems),
- ZSP (works with MX31ZL MXDECUP or, in the future, with MXULF or MX10), or

**NOTE:** ZIMO command stations will read decoder configurations automatically (in the background) and make it available when needed.

- ZSC (works with MXULF in the future or MX10).

FURTHER NOTES concerning sending in defective decoders:

To avoid unnecessary repair shipments, it should be verified beforehand whether a defect is in fact present. Many of the submitted decoders are only configured wrongly and all that was needed was a "hard reset" (CV #8 = 8) to get the decoder CVs back to the default values or the default values of a sound project.

**ATTENTION:** Sometimes defects are simulated when a loaded sound project or its integrated CV table expects a specific loco model (e.g. certain types of lighting equipment), but the equipment is missing or not wired appropriately. Typical cases are: The light is no longer working with F0 (because the sound project has redirected the light to another function key), or the locomotive will "drive off unchecked" (because the sound project activated a servo with a corresponding uncoupling procedure).

**NOTE:** for each sound project in the ZIMO sound database there is usually also a version available that contains only the sound, which does not require a specially prepared vehicle.

If the problem is "only" very poor drivability, it would be of advantage to contact [service@zimo.at](mailto:service@zimo.at) before sending the decoder back. Often a simple remedy can be found without sending the decoder back.

ZIMO can only accept decoders for repair, **BUT NOT complete engines or engine parts** with a decoder installed. There are of course exceptions in problematic cases that have to do with the interaction between the locomotive and decoder, but only after prior agreement.

The defect (or reason for return) should be described with as much detail as possible in addition to the above-mentioned information required.

So called OEM decoder i.e. those that have been factory-fitted by loco manufacturers to their own locos, should be taken care of by them. However, ZIMO will repair these as well when sent to the ZIMO service department. The warranty and repair conditions may of course differ from those of the vehicle manufacturer (whether this is "better" or "worse" is coincidence). Even in these cases: submit only the ZIMO decoder, not complete engines!

If a decoder gets exchanged, the original OEM sound project can in most cases be used in the replacement decoder as well (if the necessary information has been submitted to us). This applies to vehicle manufacturers like Roco, Fleischmann, Wunder, Demko and many others, but it is also possible that ZIMO does not have the sound from manufacturers that provided the sound themselves.

"Preloaded" sound projects (see Sound Database), however, are usually NOT available from ZIMO, but only the author / company who usually provides the sound only as preloaded in a decoder. Such sound decoders are therefore better sent directly to the original supplier. Naturally if the problem is a pure hardware issue, such as a defective motor or function output, it can be dealt easily at ZIMO.

*Repair form*  
Please fill out and accompany a ZIMO repair form with your shipment. Such forms can be downloaded here:  
[http://www.zimo.at/web2010/sales/Reparatur-Formular\\_en.pdf](http://www.zimo.at/web2010/sales/Reparatur-Formular_en.pdf)  
*Print out*

**ZIMO REPARATUR**  
zur Beilage für Reparatur-Einsendungen oder -Abgaben, auch für Garantiefälle

|   |   |
|---|---|
| Fa.<br>ZIMO ELEKTRONIK<br>Kundendienst<br>Schönbrunner Straße 188<br>A - 1120 Wien  | Zuordnung (nur von ZIMO auszufüllen)<br>Eingang: .....<br>Ausgang: .....  |
| Produkt: <input type="text"/>   | Datum: .....  |
| Kautschuk (Langtrieb) <input type="checkbox"/> Hölzler (weitere Balken) <input type="checkbox"/><br>Fehlerbeschreibung: <input type="text"/> Auch: wie oft es zum Ausfall gekommen? <input type="text"/><br><input type="checkbox"/> Fehlbildung wurde beseitigt <input type="checkbox"/> Fehlerbeschreibung siehe Email von: ..... | <b>WICHTIGE DATEN für Decoder:</b><br>Adresse: Gebiets-EPN-Nummer (CV # 7, EE)<br>Name: Sound Decoder: Decoder ID (CV # 250, ..)<br>Gebiets-Nummer/Projekt: Last-Code (CV # 260, ..)<br>verwendetes Lichtsystem: <input type="checkbox"/> Fernsteuerung<br><input type="checkbox"/> Teilleuchte<br><input type="checkbox"/> Mehrfachung (ausgelassen) oder zur Seite Stellung<br><input type="checkbox"/> Schienenlicht (ausgelassen)<br><input type="checkbox"/> Funktionsausbau (ohne) (ausgelassen)<br><input type="checkbox"/> Lichtsteuerungsgang wegschalten<br><input type="checkbox"/> Sonstiges: .....<br><input type="checkbox"/> Software-Update soll durchgeführt werden<br><input type="checkbox"/> Garantie-Anspruch<br><input type="checkbox"/> Fehler ab Einreisebetriebsname |
| Reparatur-Protokoll (nur von ZIMO auszufüllen)<br>Dringende/r Arbeit: <input type="checkbox"/> Ziel: <input type="text"/><br>Verbrauchtes Material: <input type="text"/><br>Datum: <input type="text"/> Mitarbeiter: <input type="text"/> Kosten: <input type="text"/>  | <input type="checkbox"/> Software-Update durchgeführt, neue Version:<br><input type="checkbox"/> kein Fehler gefunden!<br><input type="checkbox"/> kein Fehler bemerkt!<br><input type="checkbox"/> Garantie-Anerkennung<br><input type="checkbox"/> Kostenfreie Rep. (Kulanz)  |
| Name und Adresse<br>(bei Erhebung mehrerer Protokolle muss es sich um unterschiedliche Adressen mit email angeschlossen handeln für Telefon)<br><input type="text"/><br>Telefon: <input type="text"/><br>Email: <input type="text"/>  |   |



ZIMO Elektronik GmbH