

Thank you for your choice of the Graham Farish Class 24 diesel locomotive.

Running in

The mechanism of this model requires running in (without a load) for approximately 1 hour in each direction at moderate speed.

Curves

This locomotive is recommended for use on 12" radius curves but will operate on 9" radius curves.

Body removal

The bodyshell clips over the chassis and can be removed by carefully easing away from the chassis.

Lubrication

When required, sparingly lubricate the motor bearings using plastic compatible light oil and the gear train with model grease. Suitable lubricants are Bachmann E-Z Lube item 99984 or Woodland Scenics 'HobbyLube' Lite Oil item HL654.

DCC Decoder fitting

The model has a NMRA/NEM 651 6-pin decoder socket.

Follow the instructions supplied with the decoder. Remove the blanking board and fit the decoder, aligning as shown. We recommend that the model is run in first using a DC supply before fitting a decoder.

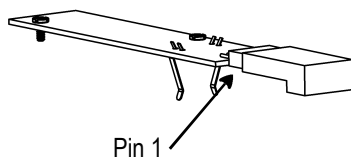

Buffer beam parts

Pipes, step and a cosmetic screw coupler can be fitted as an alternative to the functional coupler. The pipes and coupling fit in the order shown.

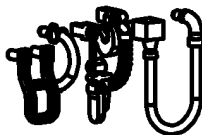

Bachmann Europe Plc

Moat Way, Barwell, Leicestershire, LE9 8EY 01455 841756

www.bachmann.co.uk

Class 24 rev 1 03/09

F7297-ISO01

Parts

- 1 Motor
- 2 Driveshaft
- 3 PCB
- 4 Bogie
- 5 Loco baseplate
- 6 Couplings
- 7 Worm and housing

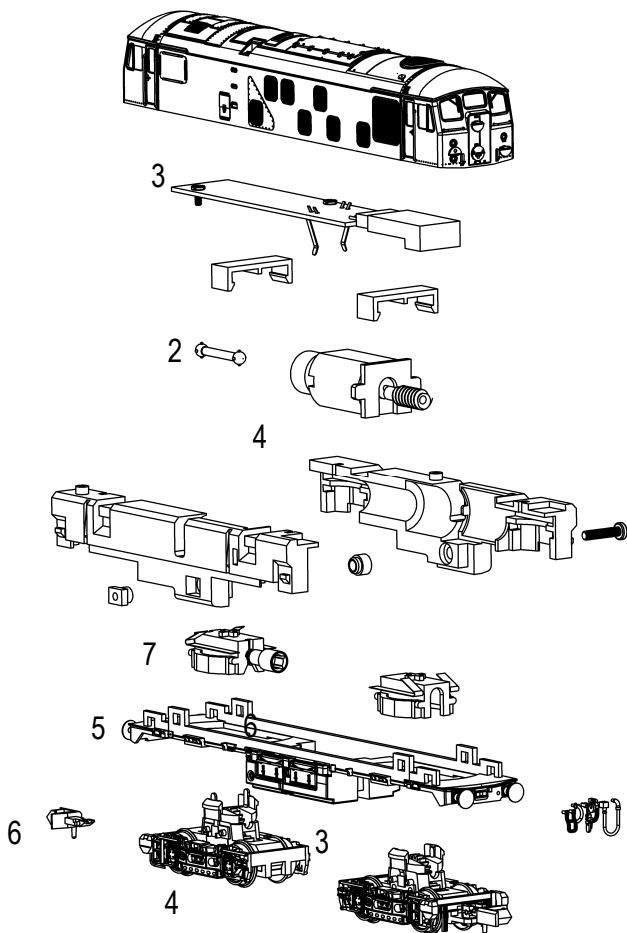

When ordering parts please quote the catalogue number together with the livery of the model (if appropriate) and number of the part required.

Parts are subject to availability.

The model should be handled carefully as it has many finely detailed parts. It is not suitable for persons under 14 years

A selection of disc headcodes applicable to the Class 24 locomotive at different periods.

⊖ open disc ◐ closed disc

1960s

1970s

◐
⊖ ◐ ⊖
Express passenger
Postal. Newspaper

Express passenger
Postal. Newspaper

⊖
◐ ◐ ◐
Ordinary / branch passenger

Ordinary / branch passenger

◐
⊖ ⊖ ◐
Fully brake fitted parcels /
perishables / ECS
Express freight brake fitted

Express parcels

⊖
◐ ⊖ ◐
Unfitted through freight

Parcels

⊖
⊖ ◐ ◐
Part fitted express freight.

Fully fitted express freight train

◐
◐ ⊖ ⊖
Part fitted freight

Part-fitted express freight train

⊖
◐ ◐ ⊖
Unfitted express freight

⊖
◐ ⊖ ◐
Unfitted through freight

Freight, mineral or ballast stopping at
intermediate stations

◐
◐ ◐ ⊖
Freight, mineral or ballast stopping
at intermediate stations

Unfitted freight train.
Branch freight / freight stopping in section

◐
⊖ ◐ ◐
Empty coaching stock

◐
◐ ⊖ ◐
Light engine

Light engine